

## TRUCK, AIR DEFENCE, LAND ROVER 6 X 6, FFR, W/WINCH, TARGET SENSOR VEHICLE (TSV)

### LIGHT GRADE REPAIR

This instruction is authorised for use by command of the Chief of Army. It provides direction, mandatory controls and procedures for the operation, maintenance and support of equipment. Personnel are to carry out any action required by this instruction in accordance with EMEI General A 001.

#### GENERAL

##### Introduction

1. This EMEI contains procedures for removing, dismantling, repairing, assembling and installing various components of the Truck, Air Defence, Land Rover 6 X 6, FFR, W/Winch, Target Sensor Vehicle (TSV) shown in Figure 1. Where applicable, instructions for the adjustment, lubrication and minor servicing of these items are included. This EMEI should be read in conjunction with EMEI Vehicle G 203.

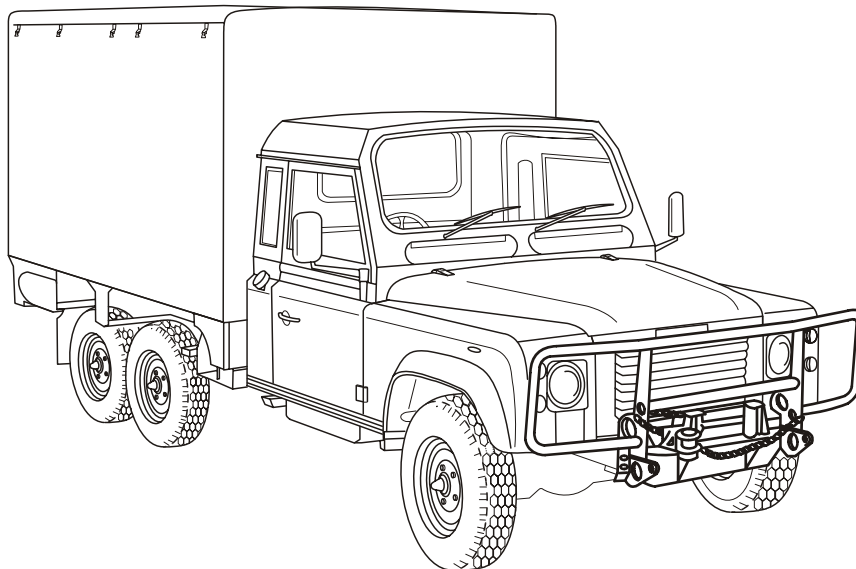

Figure 1 Truck, Air Defence, Land Rover 6 X 6, FFR, W/Winch, Target Sensor Vehicle (TSV)

#### Safety Precautions

**CAUTION**

**Do not use adhesive tapes to seal fuel or oil openings. The adhesive tape is soluble in fuel or oil and can cause contamination. Remove temporary covers before assembling.**

2. Prevent dirt and foreign objects from entering any component by placing clear temporary coverings over all exposed openings, including hoses, tubes and lines.

**CAUTION**

**Before removing any electrical system components, disconnect the battery leads.**

3. When disconnecting electrical connectors, hoses and fittings, remove clamps as required to gain slack and avoid damage to connectors and fittings.

4. Discard all used gaskets, seals, cotter pins, tab washers, lock pins, key washers, and lock washers. Discard all contaminated fuel and lubricants drained from the vehicle.
5. Use only those fuels and lubricants specified in the Servicing Instruction, EMEI Vehicle G 209, and the User Handbook when replenishing fuel or lubricants.
6. Any fastenings or fittings being tightened to prescribed torques are to have dry, clean threads unless otherwise specified. When specified, thread sealants are to be applied to dry, clean, oil-free threads.
7. The engine cooling system contains Nalcool Maximum corrosion inhibitor at a concentration of 12% total volume.
8. This vehicle is painted in polyurethane paint.

**WARNING**

**Precautions should be taken prior to carrying out repairs which include painting, sanding, scraping or welding. For safety precautions refer to Introduction into Service Instruction, Materiel Management Policy Statement, Painting Policy for Vehicles and Equipment or relevant EMEI.**

**ENGINE – GROUP 1**

**Jockey Pulley**

9. Removal:
  - a. Slacken the adjusting bolt on the jockey pulley arm (Figure 2), then rotate the pulley away from the fanbelts.
  - b. Remove the adjusting bolt from the pulley arm and mounting, then remove the pulley arm and pulley from the engine.
10. Disassembly:
  - a. Remove the grease nipple from the pulley bolt, then secure the pulley arm in a vice. Using a suitable spanner, remove the lock nut securing the pulley bolt, then remove the pulley bolt and pulley. Discard the lock nut.
  - b. Using circlip pliers, remove the internal circlip retaining the bearing in the pulley.
  - c. Remove the bearing from the pulley using a suitable drift or press.
  - d. Degrease the pulley in a suitable cleaning agent.
11. Reassembly:
  - a. Install the bearing, chamfered face first, into the pulley using a suitable drift or press.
  - b. Insert the circlip into the pulley.
  - c. Install the pulley on the pulley arm with the circlip facing the arm box, then insert the pulley bolt and a new lock nut. Install the grease nipple and lubricate with grease (XG-274).

UNCONTROLLED IF PRINTED

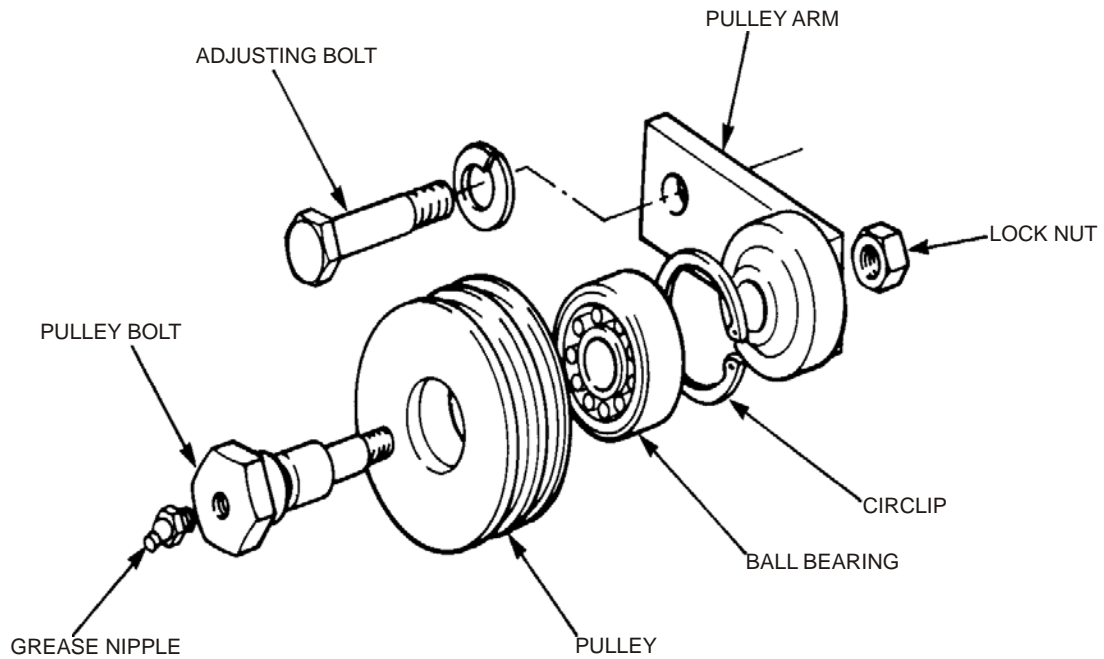

**Figure 2 Jockey Pulley - Exploded View**

**12. Installation:**

- a. Align the pulley arm bolt hole with the mounting hole, then insert the adjusting bolt.
- b. Fit the fanbelts in the pulley grooves, then position the pulley arm to allow a deflection of 5-10 mm on the longest span of the belts, and tighten the lock nut securely.

**SPECIFICATIONS**

**Table 1 Belt Deflection**

Description	Deflection
Fanbelt Deflection (12 Volt Alternator)	10-15 mm
Fanbelt Deflection (24 Volt Alternator)	5-10 mm
Drive belt Deflection	7-12 mm

**ELECTRICAL - GROUP 15**

**Cargo Area Lights**

**13. To remove a LED fitting (Figure 3):**

- a. Isolate the lights from the battery by removing leads from battery.
- b. Remove the two screws from the fitting.
- c. Pull the fitting from the mounting and pull cable to its full extent.
- d. At a suitable point, cut the cables to the defective fitting.

UNCONTROLLED IF PRINTED

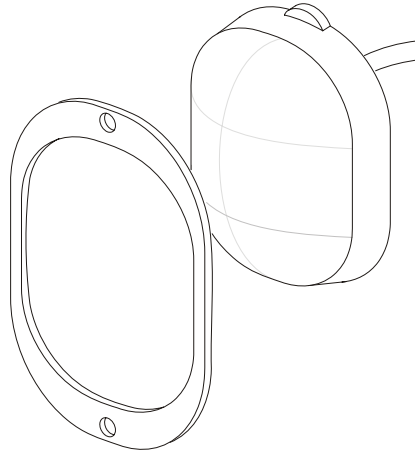

Figure 3 Cargo Area LED Fitting

14. To refit a LED fitting:
- Join the new fitting to the cables by using the suitable size cable connectors.
  - Position the new fitting into the bracket and insert and tighten the two loctite coated screws.
  - Reconnect battery supply leads and check light for operation.

#### Cargo Area Lamp Switch

15. To remove a switch (Figure 4):
- Isolate the battery supply by removing leads from battery.
  - Remove the switch plate, from the bracket above the cable reel, by removing the two screws and withdrawing.
  - Tag and disconnect the wiring harness from the light switch.
  - Remove the hexagonal nut securing the switch to the switch plate, then remove the switch.
16. To refit a switch:
- Insert the replacement switch in the switch plate and secure with the nut.
  - Connect the wiring harness to the light switch, observing the identification tags.
  - Position the switch plate over the bracket, insert and tighten the two loctite coated screws.
  - Reconnect the battery leads, turn on the switch and check that the lights operate.

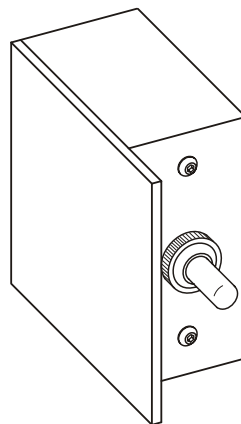

Figure 4 Cargo Area Light Switch

UNCONTROLLED IF PRINTED

### Alternator (24 Volt)

#### 17. Removal:

- a. Disconnect the vehicle battery and the FFR system batteries.
- b. Cut the lock wire securing the cannon plug to the alternator, then remove the plug.
- c. Slacken the adjusting bolt on the jockey pulley arm (Figure 2), then rotate the pulley away from the fanbelts. Detach the two belts from the alternator pulley.

#### WARNING

**The alternator is heavy. Care must be taken on removal or personal injury may result.**

- d. Support the alternator, then remove the two bolts that retain the alternator clamp rings to the mounting. Carefully remove the alternator from the vehicle. Discard the lockwashers.
- e. Remove the four bolts, nuts and washers that secure the clamp rings on the alternator, then remove the clamp rings. Discard the lockwashers.

#### NOTE

Repair procedures are detailed in the Electrical P 41 series of EMEIs.

#### 18. Installation:

- a. Fit the two clamp rings on the alternator and install the four bolts, nuts and washers, but do not tighten at this stage (Figure 5)

#### WARNING

**The alternator is heavy. Care must be taken on removal or personal injury may result.**

- b. Support the alternator and clamp rings beside the engine cylinder block, then insert the two bolts that secure the clamp rings to the mounting. Fit the two nuts and new lockwashers and tighten securely.
- c. Ensure that the alternator and crankshaft pulleys are aligned by using a suitable straight edge, then connect the cannon plug. Using new lockwashers, install the four bolts and nuts on the clamp rings and tighten the nuts securely.

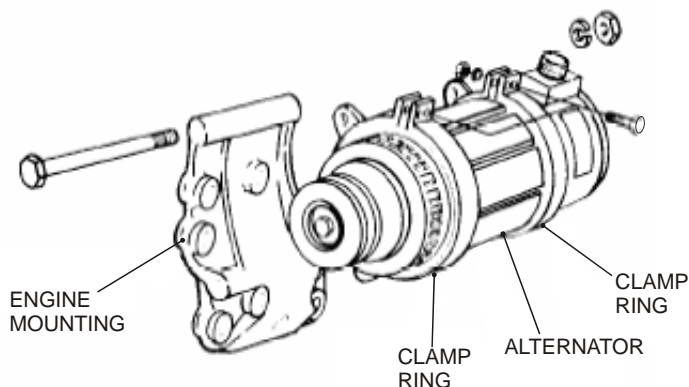

**Figure 5 Alternator – Installation**

- d. Fit the two belts in the alternator pulley grooves and check that they are correctly fitted to the crankshaft and compressor pulleys.
- e. Fit the fanbelts in the pulley grooves, then position the pulley arm to allow a deflection of 5-10 mm on the longest span of the belts, and tighten the lock nut securely.

- f. Lock wire the cannon plug to the alternator, then connect the vehicle and FFR batteries.

### Wiring Harness

19. General precautions:

- a. Use suitable testing meters or circuit testers to trace or locate faults and check circuits. The practice of arcing wires to earth to determine if the wire is live, will destroy solid state components, and must not be used.
- b. After tracing electrical faults, and before carrying out any electrical repairs, disconnect the batteries, negative terminals first.
- c. Before carrying out any electrical arc welding on the vehicle, disconnect the batteries, radio and the alternator. Failure to disconnect the alternator will cause the transistors and diodes to fail as a result of current flow throughout the chassis when arc welding.
- d. When installing the batteries, ensure that the terminals are connected to the correct posts. Reversing battery polarity will cause serious damage.

20. Replacement:

- a. Disconnect the batteries, negative terminals first, then disconnect the positive terminals (Figure 6).

#### NOTE

All chassis electrical wiring in the vehicle is colour coded for identification and reference. If necessary, refer to the wiring diagram (EMEI Vehicle G 203), in conjunction with the relevant illustration, when replacing a wiring harness. A module wiring diagram is located at the rear of this EMEI.

- b. Determine which harness is to be replaced and ensure that the replacement harness is of the correct capacity and that the wires are correctly colour coded. Using the old harness and tags as a guide, connect the wires to the appropriate terminals.
- c. Connect the batteries, the positive terminal first, then connect the negative terminal.
- d. Test the function of the components associated with the wiring harness that has been replaced to ensure correct function.

### Batteries (24 Volt Installation)

21. Replacement:

- a. Switch off the master switch on the power distribution box.
- b. Remove the security clip and pin from the battery carrier, then slide the batteries and carrier clear of the vehicle body until the small bridging cable is exposed.



**When removing the bridging cable, extreme care must be taken to prevent the cable ends shorting out on the vehicle body.**

- c. Disconnect the bridging cable from both the positive and negative terminals on the batteries. Remove the cable.
- d. Disconnect the remaining cables from the batteries.
- e. Remove the nuts and washers securing the battery retaining bracket and remove the bracket.
- f. Lift the batteries out of the battery carrier.
- g. Install the batteries in the battery carrier and secure with the retaining bracket.
- h. Connect the battery cables as shown in Figure 6, and stow the battery carrier. Secure the carrier with the security clip and pin.
- i. Switch on the master switch.

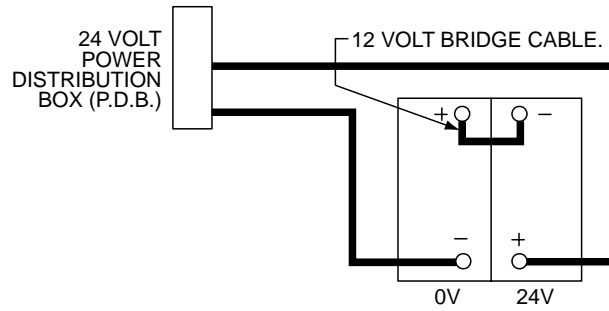

Figure 6 Batteries – Installation

## BODY - GROUP 17

### Webbing Replacement

22. Remove webbing:
  - a. Remove the webbing strap by feeding the strap back through the loop on the end of the strap and pull strap from footman's loop.
23. Refit webbing:
  - a. Refit webbing strap by pushing the loop on the end of the strap through the footman's loop.
  - b. Feed the end of the strap through the loop on the end of the strap and pull until the strap is tight on the footman's loop.

### Cable Reel Top Roller Adjustment

24. To adjust the cable reel top roller:
  - a. Release the tension on the roller by turning the knurled knob.
  - b. Move the roller to required position.
  - c. Tension the roller by turning the knurled knob.

END

Distribution List: **VEH G 21.3 – Code 2** (Maint Level)  
(Sponsor: LV SPO, Lt B Veh Section)  
(DMO Job No AMP063.69)