

ACTOVED 6 MAY 92
MM

TRUCK, CARGO, LIGHT, MC2, ALL TYPES FITTED WITH WINCH
LAND ROVER 110 6X6

REWORK OF THE WINCH REAR DRIVESHAFT

MODIFICATION INSTRUCTION

This EMEI is authorised for issue by the CGS. It provides direction, mandatory controls and procedures for the operation, maintenance and support of equipment. Personnel are to obey the instructions and follow the procedures contained in this publication.

Introduction

1. This instruction details the rework of the winch rear driveshaft due to problems with shaft dislodgement on early vehicles. The reworked driveshaft has a roll pin fitted adjacent to the slip joint to limit shaft travel, an improved grub screw fitted to aid shaft retention and Loctite 262 applied to the threads of all other winch driveline grub screws.

Note:

1. NSN and Designation used in this instruction were current at the date of issue. If twelve months or more have expired since issue, the NSN should be checked for supercession.

General

2. Estimated Modification Time. 1.0 hr (initial planning only).
3. Priority. Group 2:
 - a. All equipments on issue to units are to be modified when next in workshops for repair.
 - b. All equipments held by supply units should normally be modified before issue, however where this would delay priority issues equipments may be released unmodified provided their GM 120 is endorsed with details of the outstanding modification.
4. Modification to be Applied to. Later vehicles were modified in production and only the following variants are to be modified:
 - a. Truck, Cargo, Light, Winch:
 - (1) ARN 50724 - 50743; and
 - (2) ARN 50572 - 50583;
 - b. Truck, Air Defence, Light, FFR, Winch:
 - (1) ARN 50664;
 - (2) ARN 50667 - 50714; and
 - (3) ARN 51858 - 51872; and
 - c. Truck, Ambulance, Light, 4 Litter, FFR, Winch - all to be modified.

UNCONTROLLED WHEN PRINTED

5. Items Affected. Winch Rear Driveshaft.

6. Action Required. By RAEME units authorised to carry out unit, field and base repairs.

TABLE 1 - STORES REQUIRED (To be demanded through Moorebank Logistic Group)

| Item | MPN/NSN | Designation | Qty per Equip |
|------|--|--|---------------|
| 1. | 1111-97-121-2988 <i>255-11 217211</i> | Kit, Winch Driveshaft, JRA No AYG3617, comprising items 1 and 2 in Table 2 | 1 |
| 2. | 8040-66-089-2870 | Loctite 262, 10 ml bottle | 1 |

Note:

1. Parts Kits are provided by Land Rover Australia and are not to be procured locally. Kits are to be ordered on the basis of one kit per vehicle and are not to be ordered for stock.

TABLE 2 - COMPONENTS CONTAINED IN MODIFICATION KIT
(Not to be indented for to complete the modification).

| Item | MPN/NSN | Designation | Qty per Equip |
|------|------------------|--|---------------|
| 1. | 5315-66-128-4539 | Roll pin, Winch shaft JRA No PA112301 | 1 |
| 2. | 5305-66-128-6104 | Screw, Grub, 3/8 UNC, cone point, 1/2 long JRA No MYH 3571 | 1 |

Detail

7. The modification is to be carried out as follows, with reference to Fig 1 for component location:

- a. Locate the sliding joint on the winch rear driveshaft and mark the shaft 8 - 9 mm from the sliding joint.
- b. Remove the winch rear driveshaft, ensuring that the driveshaft is indented at the position of the existing rear grub screw.
- c. If the grub screw position is not clearly identifiable, refit the driveshaft and carefully drill through the threaded grub screw hole on the PTO flange to mark the shaft.
- d. Using a 6 mm drill bit, spot drill the driveshaft at the rear grub screw mounting point to a depth of 3 mm.
- e. Locate the previous mark on the sliding joint end of the driveshaft and using a 6 mm drill bit drill through the shaft and fit the roll pin (item 1 from Table 2).

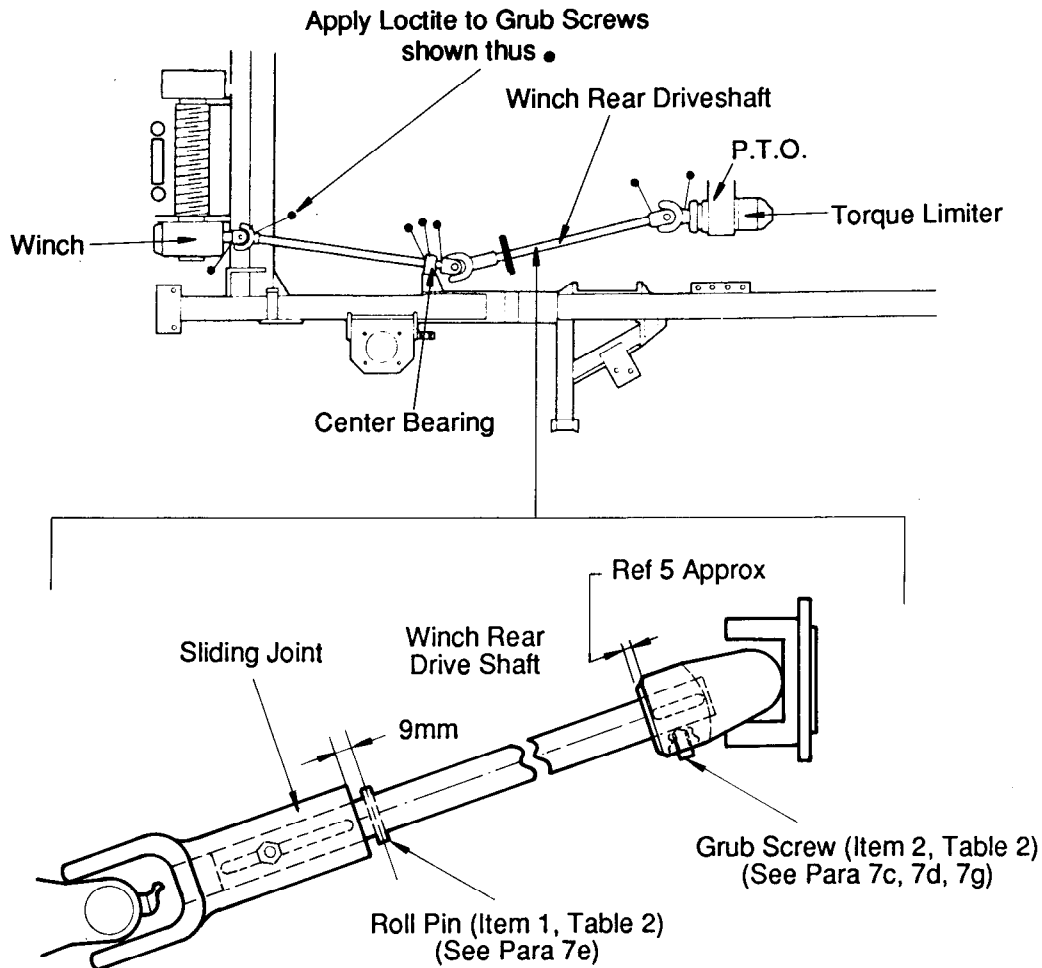

FIG 1 - WINCH REAR DRIVESHAFT REWORK

- f. Refit the driveshaft to the flange and sliding joint.
- g. Fit and tighten the new grub screw (item 2 from Table 2) to the rear driveshaft flange after applying Loctite 262 (item 2 from Table 1) to the screw threads, ensuring the point of the grub screw indents into the shaft.
- h. Remove all other winch driveline grub screws, apply Loctite 262 to the threads, refit and tighten the screws.
- i. Test the operation of the winch.

8. Modification Record Plate. Deface the numeral 13 on the modification plate located on the drivers seat base including the vehicles modified in production.

9. Recording. Enter the details of the modification in Part 3 of the TGM 120, Record Book for Service Equipment, for the subject vehicles, including the vehicles modified in production.

E N D

UNCONTROLLED WHEN PRINTED