

TRUCK, CARGO, LIGHT, MC2 LANDROVER 110 - ALL TYPES

FITTING OF THE STEERING PROTECTION PLATE AND  
IMPROVED WINCH FAIRLEAD PLATE MOUNTING BOLTS

MODIFICATION INSTRUCTION

Issue of this instruction is authorized by CONMEA

Introduction

1. This instruction details the fitting of a steering protection plate to provide additional protection to steering components and the fitting of longer winch fairlead plate mounting bolts. Later variants will have the protection plate fitted, however the winch fairlead plate to winch housing mounting bolts must still be checked and replaced.

Note:

1. NSN/MPN and Designation used in this instruction were current at the date of issue. If twelve months or more have expired since issue, the NSN/MPN should be checked for supersession.

General

2. Estimated Modification Time. 1 hr (initial planning only).
3. Priority. Group 2.
4. Modification to be Applied to. All subject vehicles.
5. Items Affected. Steering rods, chassis and winch.
6. Action Required. By RAEME units authorised to carry out unit, field and base repairs.

TABLE 1 - STORES REQUIRED

(To be demanded through normal supply channels through Moorebank Logistic Group)

Item	MPN/NSN	Designation	Qty per Equip
1.	2540-66-128-6017	KIT, PROTECTOR, STEERING COMPRISING ITEMS 2 TO 9	1
2.	2540-66-128-6024	PROTECTOR, GUARD	1
3.	5310-99-122-6477	WASHER, FLAT	7
4.	5310-99-943-4300	NUT, NYLOC, 1/2 INCH UNF	2
5.	5306-66-128-6018	BOLT, 1/2 INCH UNF, 6 1/2 INCH LG	1
6.	5365-66-128-6021	SPACER, ROUND	1
7.	5365-66-128-6022	SPACER, FLAT	2
8.	5306-99-122-2787	BOLT, 12MM DIAMETER, 45MM LG	8
9.	5310-66-128-5111	WASHER, LOCK	4
10.	8030-66-091-3418	LOCTITE 271, 50 ML BOTTLE	1
11.	5180-66-131-6876	TOOL KIT, SCREW THREAD INSERT, METRIC, 4MM TO 12MM, OVERSIZE	AS REQUIRED (refer Para 7a Note 2)

Detail

7. The modification is to be carried out as follows:

- a. Remove the centre bumper (cargo variants) or the winch fairlead plate (winch variants).

Note:

1. Check the rear winch mounting bolts for security before removing the fairlead plate.
  2. Inspect the four winch housing mounting bolt holes (for the winch fairlead plate). If the threads are damaged, repair by the use of a thread insert 12mm diameter, 1.75mm pitch, available in Tool Kit Thread Insert (Table 1, Item 11) before proceeding with the modification. The Tool Kit is only to be demanded if threads are damaged.
- b. Remove the lower Panhard rod mounting arm to chassis mounting bolt and fit the Right Hand Rear (RHR) protector mount using an additional plain washer and new nut, (items 2, 3 and 4 from Table 1), as shown in Fig 1.

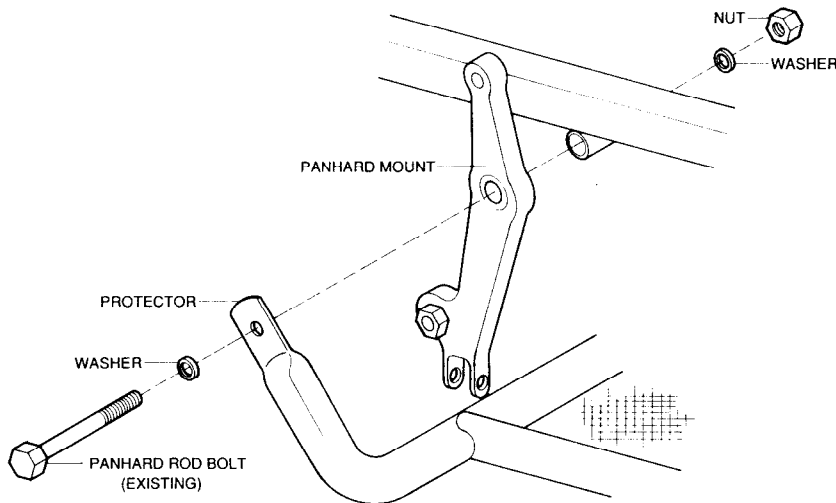

FIG 1 - RHR PROTECTOR PLATE MOUNTING

- c. Raise the rear of the protector and fit the Left Hand Rear (LHR) protector mount to the corresponding chassis mounting hole using a new bolt, nut, washers and spacer (item 3, 4, 5 and 6 from Table 1), as shown in Fig 2.
- d. Tighten the rear mounting bolts and nuts, allowing enough clearance for the front of the protector to be raised to align the protector mounting holes with the inner brushguard mounting holes.
- e. On variants with winch, fit the spacer (item 7 from Table 1), between the winch fairlead plate and the winch, as shown in Fig 3. Use new mounting bolts and washers (item 3, 8 and 9 from Table 1) and ensure that Loctite 271 is applied to the bolt threads.
- f. Secure the centre bumper or winch fairlead plate using new mounting bolts (item 8 from Table 1) and the existing nuts and washers.
- g. Tighten all mounting bolts.

UNCONTROLLED WHEN PRINTED

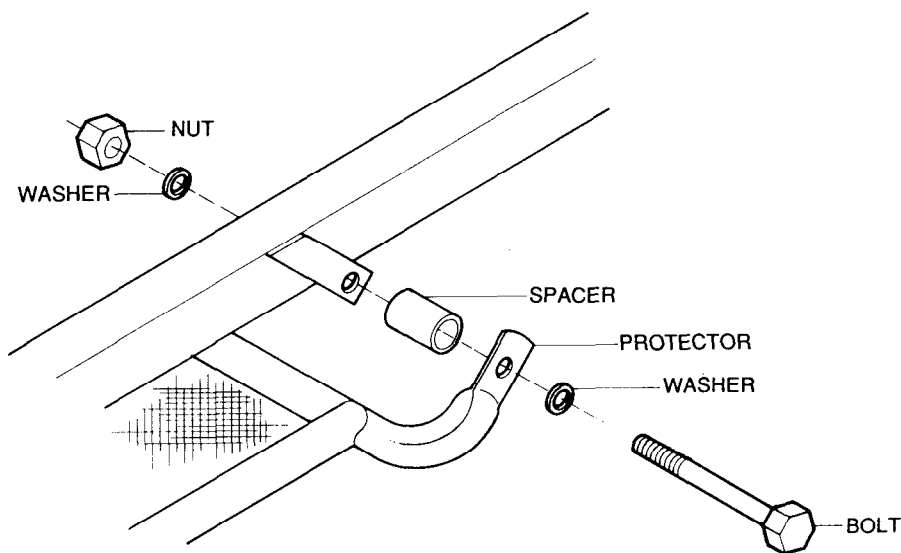

FIG 2 - LHR PROTECTOR PLATE MOUNTING

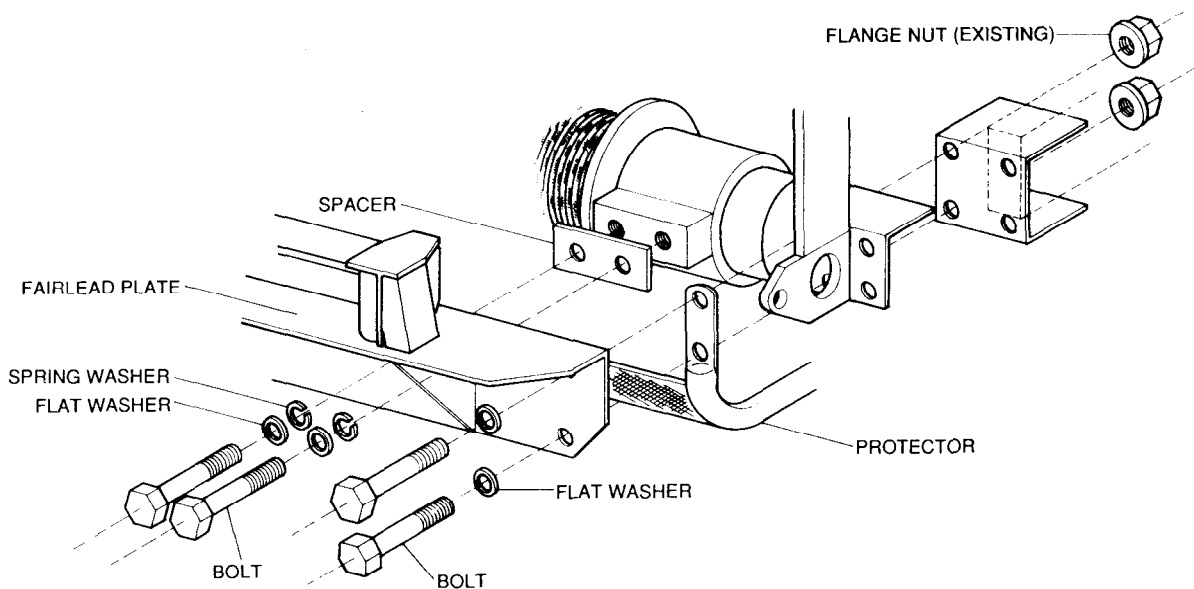

FIG 3 - FRONT WINCH FAIRLEAD PLATE MOUNTING

8. Modification Record Plate. Deface the numeral 5 on the modification plate located on the driver's seat base, including those vehicles modified in production.
9. Recording. Enter the details of the modification in Part 3 of the TGM 120, Record Book for Service Equipment, for the subject vehicles, including those vehicles modified in production.

E N D

UNCONTROLLED WHEN PRINTED