

TRUCK, CARGO, LIGHT, MC2 LANDROVER 110 - ALL TYPES 6x6

FUSING OF ADDITIONAL CIRCUITS

MODIFICATION INSTRUCTION

Issue of this instruction is authorized by CONMEA

Introduction

1. This instruction details the fusing of the instrument light and inspection light socket circuits on all variants and on FFR variants the fusing of the FFR lamp.

Note:

1. NSN/MPN and Designation used in this instruction were current at the date of issue. If twelve months or more have expired since issue, the NSN/MPN should be checked for supersession.

General

2. Estimated Modification Time. 1 hr (initial planning only).
3. Priority. Group 2.
4. Modification to be Applied to. All subject vehicles up to and including ARN 50582.
5. Items Affected. Instrument light, inspection light socket and FFR lamp circuits.
6. Action Required. By RAEME units authorised to carry out unit, field and base repairs.

TABLE 1 - STORES REQUIRED
(To be demanded through Moorebank Logistic Group)

Item	NSN	Designation	Qty per Equip
1.	5920-66-128-6036	KIT, FUSE CABLE AND LABEL NON FFR VARIANTS, COMPRISING ITEMS 3, 4, 5	1
2.	5920-66-128-6037	KIT, FUSE CABLE AND LABEL FFR VARIANTS COMPRISING ITEMS 3, 4, 5, 6, 7	1
3.	6150-66-128-6030	CABLE LINK FUSED 15 AMP INSPECTION SOCKET (JRA NO BYG 9119)	1
4.	6150-66-128-6031	CABLE LINK FUSED, 5 AMP DIMMER SWITCH (JRA NO BYG 9120)	1
5.	7690-66-128-6034	LABEL (JRA NO BYG 9118)	1
6.	5920-66-128-6033	FUSE HOLDER COMPLETE WITH TERMINALS FFR LAMP (JRA NO BYG 9073)	1
7.	5920-99-767-2990	FUSE 5 AMP (JRA NO RTC 4497)	1

UNCONTROLLED WHEN PRINTED

592-3

TABLE 2 - STORES REQUIRED
(To be demanded through normal supply channels)

Item	NSN	Designation	Qty per Equip
1.	5975-00-111-3208	CABLE TIE	2
2.	5940-66-018-0129	TERMINAL	1

Detail

7. The modification is to be carried out as follows:
- a. Disconnect the battery.
 - b. Remove the ashtray.
 - c. Using a small screwdriver slacken the screw securing the knob to the blackout switch and push in the spring loaded pin to release the dimmer switch knob.
 - d. Remove the two screws securing the dash fascia plate and remove the fascia and mounting plates from the dash.
 - e. Disconnect the brown wire to the positive (red) inspection light socket.
 - f. Fit the 15 amp fused cable link (item 3 from Table 1) between the brown wire and the positive inspection socket terminal.
 - g. Inspect the dimmer switch for serviceability and modify the dimmer switch wiring as follows:
 - (1) Locate the white wire from the map light to the connecting block above the blackout switch.
 - (2) Disconnect the white wire and replace the bullet connector with the blade terminal (item 2 from Table 2).
 - (3) Disconnect the red/white wire from the dimmer switch, connect it to the white wire and refit them to the dimmer switch.
 - (4) Remove the white cable connecting the dimmer switch to the main harness and replace it with the 5 amp fused cable link (item 4 from Table 1).
 - h. Interlock the fuse holders with the cable tie (item 1 from Table 2).
 - i. Attach the label (item 5 from Table 1) to the inside surface of the fuse cover as shown in Fig 1.
 - j. Identify the brown wire with white indent, in the vicinity of the blackout switch, and ensure that the crimped connector on the wire is serviceable and fits securely into the connector on the brown/white wire.

Note:

1. These wires connect the main lighting switch to the blackout lighting switch.

UNCONTROLLED WHEN PRINTED

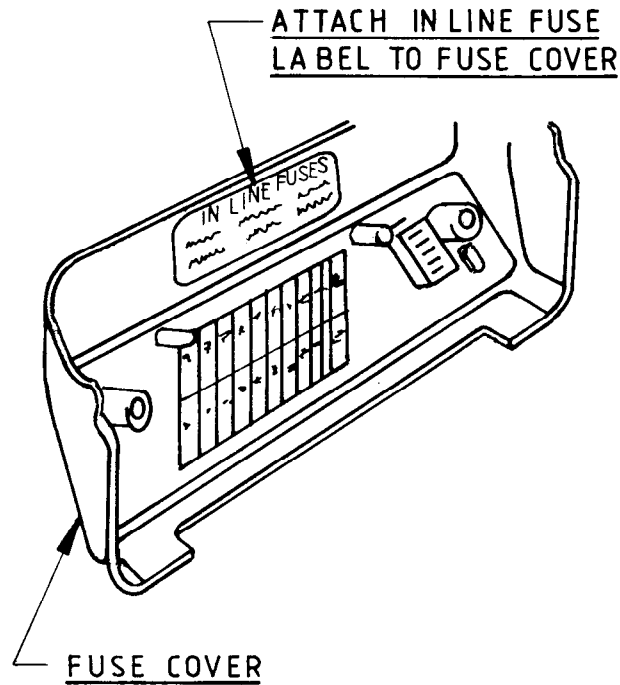

FIG 1 - FUSE COVER

- k. Refit the mounting bracket and fascia plate to the dash.
- l. Reconnect the battery and check that the inspection socket and instrument dimmer switch function correctly.
- m. Refit the blackout and dimmer switch knobs and the ashtray.
- n. On FFR variants:
 - (1) Disconnect the radio batteries.
 - (2) Identify the red wire to the FFR lamp, as shown in Fig 2, cut the wire and fit the fuse holder and crimp terminals (item 6 from Table 1) to the wire.

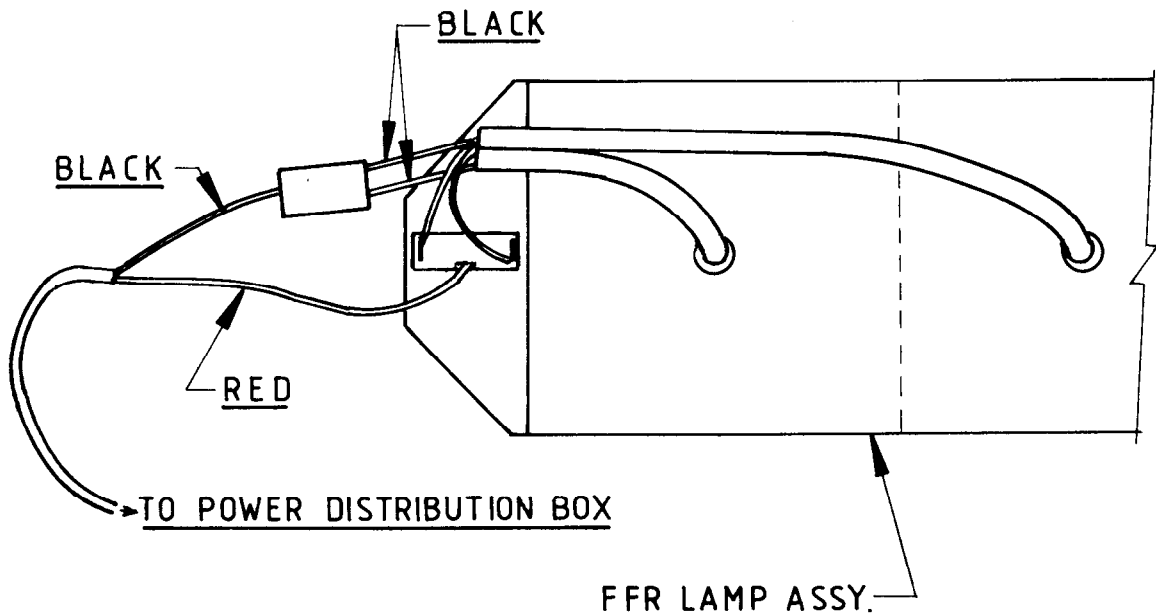

FIG 2 - FFR LAMP

UNCONTROLLED WHEN PRINTED

(3) Fit a 5 amp fuse (item 7 from Table 1) to the holder and attach the holder to the loom with a cable tie (item 1 from Table 2).

(4) Reconnect the radio batteries and test the operation of the FFR lamp.

8. Modification Record Plate. Deface the numeral 3 on the modification plate located on the driver's seat base, including those vehicles modified in production.

9. Recording. Enter the details of the modification in Part 3 of the TGM 120, Record Book for Service Equipment, for the subject vehicles, including those vehicles modified in production.

E N D

UNCONTROLLED WHEN PRINTED