

TRUCK, CARGO, LIGHT, MC2, LAND ROVER 110 6X6 - ALL TYPES

REPLACEMENT OF THE LOWER THROTTLE LINKAGE LEVER

MODIFICATION INSTRUCTION

This instruction is authorised for use by command of the Chief of the General Staff. It provides direction, mandatory controls and procedures for the operation, maintenance and support of equipment. Personnel are to carry out any action required by this instruction in accordance with GENERAL A 001.

Introduction

1. This instruction details the replacement of the existing lower throttle linkage lever with a modified lever and adjustments to the fuel injection pump, to allow full throttle travel. The replacement is due to an Engineering Change by Land Rover Australia and is necessary to ensure full power is obtained whilst driving.

NOTE

DSN, MPN and Designations used in this instruction were correct at the time of issue. If 12 months or more have passed since issue, the DSN or MPN should be checked for supersession.

General

2. *Associated Publications.* The latest issue of the following references should be read in conjunction with this instruction:

- a. Workshop A 850 - Modifications, Trial Modifications and Local Modifications to Equipment; and
- b. Workshop A 851 - Modifications to Equipment - Use of Modification Record Plates and Documentary Requirements.

3. *Authority.* Land Rover Australia Engineering Change 2183.

4. *Modification Application.* Details are as follows:

- a. The following variants require modification:
 - (1) Truck, Ambulance, Light - all up to and including ARN 50890;
 - (2) Truck, Long Range Patrol, Light - all up to and including ARN 50872;
 - (3) Truck, Cargo, Light - all up to and including ARN 51953;
 - (4) Truck, Air Defence, Light - all to be modified;
 - (5) Truck, General Maintenance, Light - all to be modified; and

(6) Truck, Electronic Repair, Light - all to be modified.

b. Stock engines delivered to Bandiana Log Gp have been modified and Engine Numbers are as follows: 325786, 325790, 325795, 325798, 325814, 326492, 326494, 326496, 326499, 326501, 326503, 329638, 329639, 329640, 329642, 329644, 329663, 330768 and 330771.

5. *Items Affected.* Throttle linkages and Fuel Injection Pump.

6. *Priority - Group 2.* All applicable equipment is to be modified:

- a. when next in workshops for repair, or
- b. prior to issue from depot or pool stock.

NOTE

Where modification would delay priority issues of depot or pool stock, equipment may be issued unmodified providing the Record Book for Service Equipment (GM 120) is endorsed with details of the outstanding modification.

7. *Action Required.* Actions detailed in this instruction may be performed by RAEME units or sub units authorised to carry out unit, field or base repairs, subject to the availability of the special tools detailed in paragraph 11.

8. *Estimated Manhours to Perform.* For initial planning purposes only, it is estimated that this modification will take 1.0 manhours to perform.

9. *Items to be Removed.* The items to be removed are listed in Table 1. All stores removed are to be processed in accordance with GENERAL P series.

10. *Stores Required.* The stores required are listed in Table 2. All stores are to be demanded through Moorebank Log Gp. Parts are provided by Land Rover Australia free of charge and are not to be procured locally. Parts are supplied on the basis of one lever per vehicle and are not to be ordered for stock.

UNCONTROLLED WHEN PRINTED

Table 1 - Stores to be Removed

Item	Manufacturer's Part No	Description	Qty per Equip
1	8943384121	Lever, "B"	1

Table 2 - Stores Required to Complete the Modification (To be demanded through Moorebank Log Gp)

Item	DSN	Mfr Part No	Description	Unit of Issue	Qty per Equip
1	2540-97-121-2999	AYG0558	Lever Throttle	ea	1

11. **Special Equipment Required.** Tachometer with a range from zero to 4000 RPM. The Tachometer, Photoelectric, Non Self Generating, NSN 6680-66-049-7072, contained in Test Set, Engine Diagnosis NSN 4910-66-049-7073 is a suitable item, however any equivalent item may be used.

Modification Detail

12. The modification is to be carried out as follows:

- a. Ensure that the engine is at operating temperature.
- b. Replace the lower throttle lever, see Figure 1, with the new lever (item 1 from Table 2), ensuring that the link rod mounting hole is toward the front of the engine.
- c. Leave the link rod ball joint disconnected from the throttle lever and, if necessary,

adjust the maximum speed bolt on the fuel injection pump governor to obtain 3550 - 3650 rpm and the idle set bolt to obtain 630 - 670 rpm (Figure 2 shows the relative screws).

- d. Refit and adjust the link rod to achieve 3550 - 3650 rpm when the accelerator pedal is fully depressed.

NOTE

It may be necessary on some vehicles to remove and trim the link rod (see Figure 1) by 5 mm to allow full adjustment of the linkages.

- e. If engine idle speed exceeds 630 - 670 rpm bend the tang at the top of the accelerator pedal, see Figure 3, to allow the pedal to fully return to the idle position.

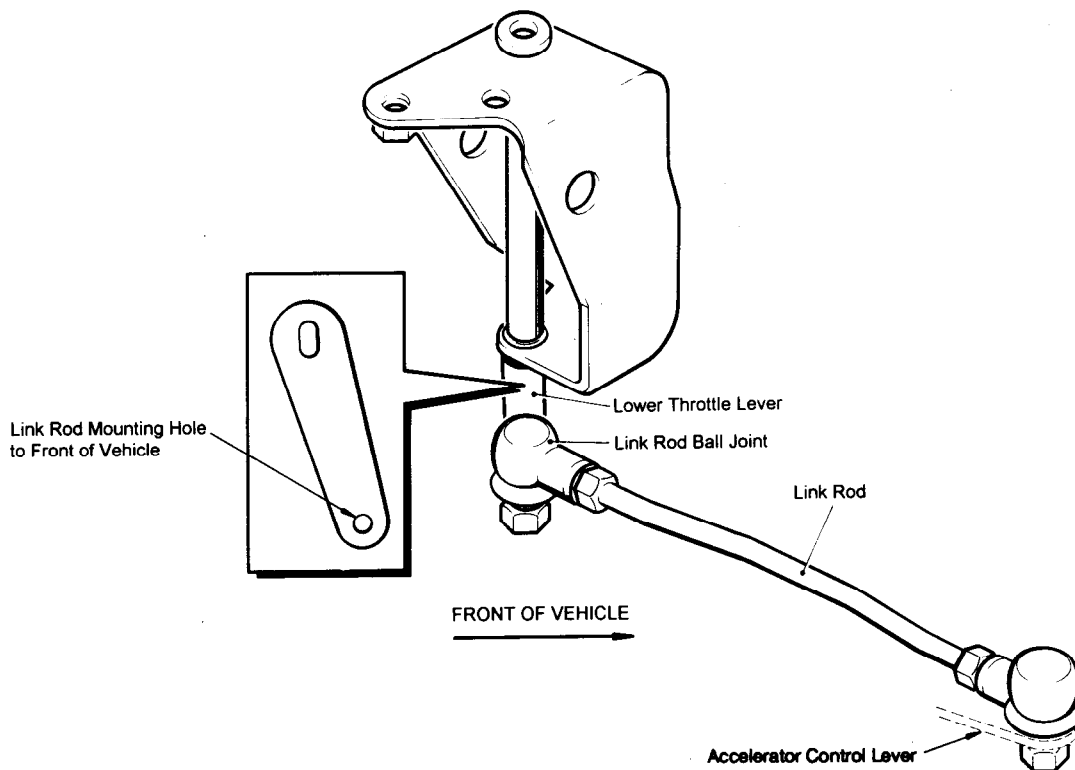

Figure 1 - Throttle Linkages

UNCONTROLLED WHEN PRINTED

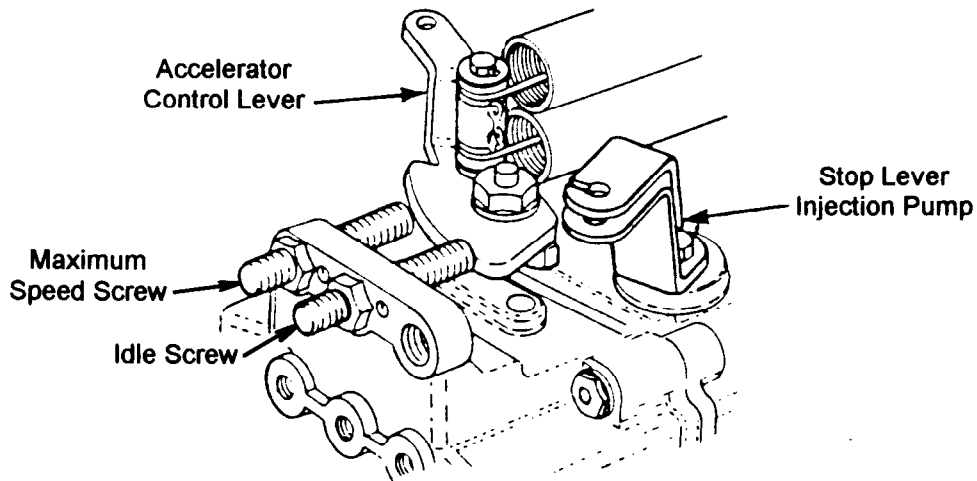

Figure 2 - Idle and Maximum Speed Screws

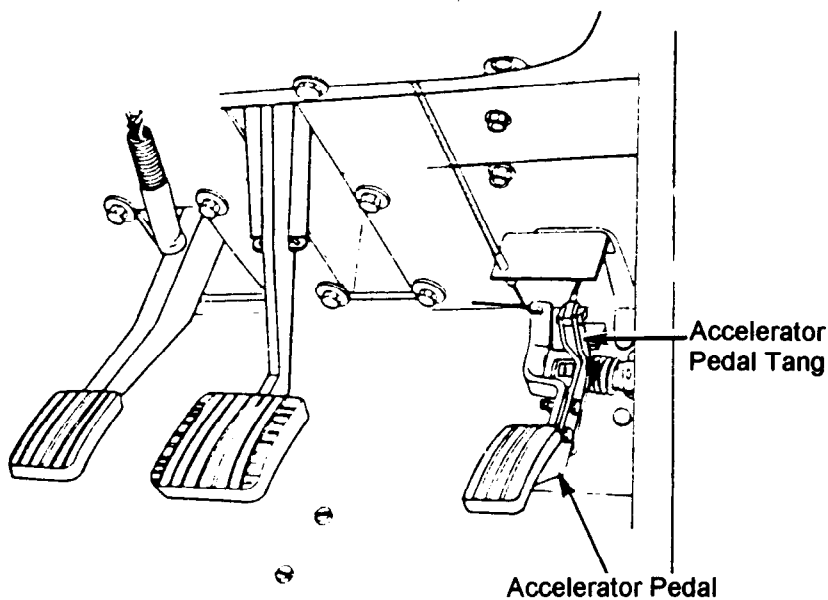

Figure 3 - Accelerator Pedal Tang

13. **Post Modification Testing.** Road test the vehicle.

14. **Recording Action.** On completion of the modification:

- a. deface the numeral 19 on the modification plate located on the driver's seat base, including the vehicles modified in production; and

- b. enter the details of the modification in Part 3 of the GM 120, Record Book for Service Equipment, for the subject vehicles, including the vehicles modified in production.

END

List VEH G 20.0 - Code 4 (MEA 910421)

UNCONTROLLED WHEN PRINTED