

TRUCK, GENERAL MAINTENANCE, LIGHT, WINCH, MC2 - LANDROVER 110 6X6

INSTALLATION OF A MAINTENANCE MODULE BATTERY ISOLATION SWITCH AND AN AUXILLARY ALTERNATOR CHARGE INDICATOR LAMP RELAY

MODIFICATION INSTRUCTION

This instruction is authorised for use by command of the Chief of Army. It provides direction, mandatory controls and procedures for the operation, maintenance and support of equipment. Personnel are to carry out any action required by this instruction in accordance with EMEI General A 001.

INTRODUCTION

1. This instruction details changes to the 24-V dc wiring in the maintenance module fitted to the Landrover maintenance vehicle (GMV) (NSN 2320-66-128-5309) to improve overall wiring safety and prevent the possibility of damaged or faulty internal wiring leading to electrical short circuits and/or fires when the vehicle is unattended. The modifications were developed as the result of an investigation into an electrically initiated fire that destroyed an unattended GMV. The changes detailed in this instruction involve:

- a. the installation of a new externally accessible double pole battery isolation switch to disconnect the 24-volt module batteries from the module's internal dc wiring;
- b. the complete removal of the junction box and jumper terminals assembly adjacent to the module battery carrier, including the existing 24-volt auxiliary alternator charge indicator lamp relay;
- c. the installation of a new charge indicator lamp relay for the 24-volt alternator in the vehicle engine bay; and
- d. fitting of a modification record plate to the maintenance module.

2. **Associated Publications.** Reference may be necessary to the latest issue of the following documents:

- a. Repair Parts Scale 02209 - Truck, General Maintenance, L/Rover 110, Isuzu Diesel Engine, W/Winch Turbocharged, 6x6, 2 Tonne, MC2;
- b. Technical Regulation of Army Materiel Manual (TRAMM) (available from DTR-A website <http://intranet.defence.gov.au/armyweb/Sites/DTRA>);
- c. TRAMM, Volume 3, Section 2, Chapter 2, Fleet Engineering Change Management Process;
- d. Defence Supply Chain Manual (DSCM), Volume 4, Section 3 – Supply Management Processes, Stores Accounting General (DSCM website <http://dknln009.car.defence.gov.au/dscm/index.htm>); and
- e. DSCM, Volume 6 – Manage Repairable Items.

3. **Authority.** Engineering Change Order (ECO) LTB 026/06 is the authority to carry out this modification.

GENERAL

4. **Modification Application.** This modification is to be applied to all Landrover 110 6x6 GMV on issue to units and in service storage.

5. **Items Affected.** This modification alters the following assemblies:

- a. the junction box and jumper terminals assembly and associated wiring (RPS 02209, Group QBB);
- b. the 24-volt battery carrier on the front left-hand side (LHS) of the maintenance module; and
- c. the engine bay.

6. **Priority – Group 2.** All applicable equipment is to be modified:

- a. when next in a workshop for Light, Medium or Heavy Grade Repair; or
- b. prior to issue from depot or pool stock.

NOTE

Where modification would delay priority issues of depot or pool stock, equipment may be issued unmodified providing the equipment record book is endorsed appropriately.

7. Action Required. Actions detailed in this instruction are to be performed by technical maintenance organisations authorised to carry out Light, Medium or Heavy Grade Repairs by tradespeople, ECN 418 – Technician Electrical or civilian equivalent.

NOTE

On receipt of this instruction, enter all relevant information other than date completed in the modifications section of the GM 120 – Record Book for Service Equipment.

8. Standard Job. Standard job number 7286 has been raised in MMM and is to be used.

9. Estimated Workhours. For initial planning purposes only, it is estimated that this modification will take 3 workhours to perform.





10. Stores Required. All stores required are included in the modification kit as detailed Table 1. The modification kit is to be obtained through normal supply channels.

Table 1 Stores Required

UNCONTROLLED IF PRINTED

Item	NSN	Mfr Part No	Designation or Description	Unit of Issue	Qty Per Kit	Qty Per Equip
1	6140-66-156-9676		Modification Kit, Maintenance Module Battery Isolation Switch (includes items 2 to 21)	ea		1
2	5930-66-156-7699	Hella 4657	Switch, Rotary, Master, Battery, double pole - 4 post, zinc plated housing. 	ea	1	1
3	5945-66-152-5261	Hella 3053	Relay, Miniature, 4-pin, 12-volt coil, normally open contacts (40 Amp) 	ea	1	1
4	5340-66-150-2472	Blackwoods 0062 7356	Bracket, Right Angle, 125 x 100 mm, zinc plated 	ea	2	2
5	5305-66-147-5455	10616798-35	Screw Cap, Socket, M8 x 35 mm, button head, zinc plated 	ea	4	4
6	5305-01-495-3359	Blackwoods 0361 7067	Screw, Machine, M6 x 20 mm, Pan head, Phillips #2, zinc plated 	ea	1	1
7	5310-66-149-9975	Blackwoods 0209 3400	Nut, Self-locking, Hexagon, M8. zinc plated 	ea	4	4
8	5310-66-149-9974	Blackwoods 0209 3303	Nut, Self-locking, Hexagon, M6. zinc plated 	ea	1	1
9	5310-66-150-1552	Blackwoods 0534 8602	Washer, Flat, M8, zinc plated 	ea	8	8
10	5310-66-150-1550	Blackwoods 0534 8505	Washer, Flat, M6, zinc plated 	ea	2	2

Table 1 Stores required (Continued)

Item	NSN	Mfr Part No	Designation or Description	Unit of Issue	Qty per Kit	Qty per Equip
11	5940-66-149-7286	Blackwoods 0414 7764	Terminal, Eye, 8.4 mm, 5 to 6 mm cable diameter, yellow 	ea	3	3
12	5940-66-149-7288	Blackwoods 0414 7956	Terminal, Eye, 10 mm, 5 to 6 mm cable diameter, yellow	ea	5	5
13	5940-66-150-5827	Blackwoods 0180 0562	Terminal, Quick Connect, Fully Insulated, blue, 2.5 mm cable 	ea	4	4
14	5950-66-149-7121	Blackwoods 0414 4260	Cable Joiner, Double Grip, 6 mm cable, yellow 	ea	1	1
15	5970-66-149-7444	Blackwoods 0292 9951	Heatshrink Tubing, Black, 5 mm nom, 2.5 mm shrink diameter	metres	0.5	0.5
16	6145-66-156-7700	Bambach 28320 (specify colour)	Wire Electrical, 4 mm ² , Tinned, PVC insulation, red	metres	1.5	1
17	6145-66-156-7701		Wire Electrical, 4 mm ² , Tinned, PVC insulation, white	metres	1	1
18	6145-66-156-7702		Wire Electrical, 4 mm ² , Tinned, PVC insulation, black	metres	1	1
19	9905-66-016-3535		Plate, Modification Record, aluminium	ea	1	1
20	5940-66-128-6150	MA14N (neg) MA14P (pos)	Terminal Assembly, Battery (specify positive – red wingnut, or negative – black wingnut, as required) 	ea	2 2	2 2
21	5975-12-199-8964	T50R	Strap, Tiedown, Electrical Components (cable tie)	ea	10	10

11. Items to be Removed. The complete junction box and jumper terminals assembly fitted above the module battery tray under the front LHS of the maintenance module is to be removed and processed in accordance with DSCM, Volume 4, Section 3 – Supply Management Processes, Stores Accounting General. The components to be removed are illustrated and detailed in RPS 02209 Group QBB.

DETAIL

Removal of the Junction Box and Jumper Terminals Assembly

- 12.** Remove the junction box and terminals assembly as follows:
- a.** Disconnect the negative lead from the main vehicle battery in the engine bay.
 - b.** Fully open the LHS door on the maintenance module and secure it in the open position with the locking mechanism on the gas support struts.
 - c.** Remove the securing pin and slide the module battery tray out to the fully extended position, remove the battery cover and disconnect all the cables connecting the batteries to the module.
 - d.** Remove the two screws securing the mounting brackets for the junction box and jumper terminals assembly to the module floor (Figure 1).

UNCONTROLLED IF PRINTED

CAUTION

Some junction box and jumper terminals assemblies may not be configured exactly as illustrated in Figures 2, 3 and 4. Conduit entry locations and wiring colours may vary. If this is the case, carry out all necessary actions to remove the complete assembly leaving only the residual wiring described below.

- e. Disconnect the red alternator cable and the black earth cable from the terminal bolts on either side of the jumper terminals box (Figures 2 and 3).

NOTE

These cables will be reconnected to the batteries later in this procedure.



Figure 1 Junction Box Securing Screws



Figure 2 Red Alternator Cable

UNCONTROLLED IF PRINTED

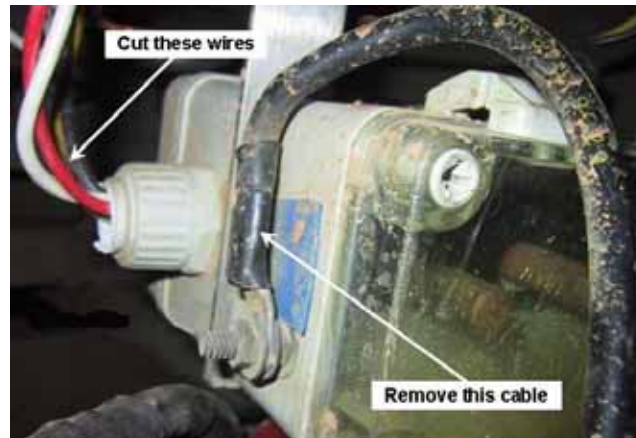

Figure 3 Black Earth Cable to be Disconnected and Wires to Cut

- f. Cut all the wires passing out of the cable gland on the side of the junction box (Figure 3).
- g. Identify the brown 12-volt ignition wire connected to one of the relay coil terminals in the junction box (Figure 4).

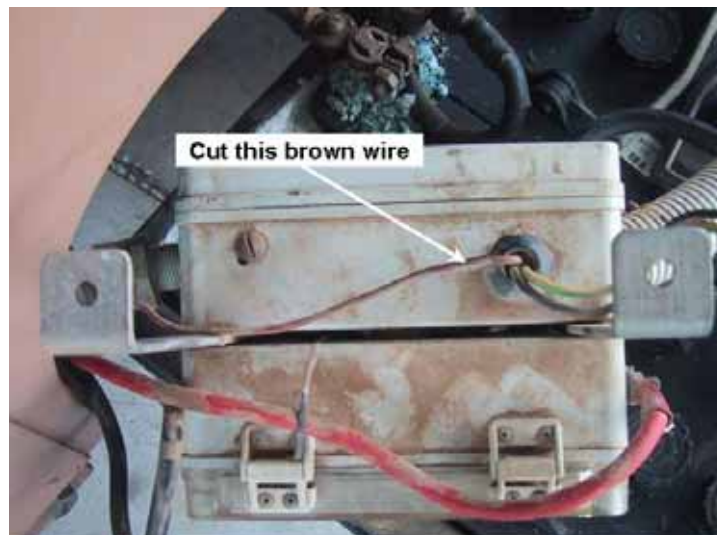

Figure 4 12-volt Vehicle Ignition System Wire

- h. Cut this wire near the junction box.

NOTE

This wire will be drawn back into the vehicle engine bay later in this procedure.

- i. Remove and discard the junction box and jumper terminals assembly and the remaining wires attached to it.

Installation of a New Auxillary Alternator Charge Indicator Lamp Relay

NOTE

The original 24-volt auxiliary alternator charge indicator lamp relay and associated wiring were part of the junction box and jumper terminals assembly removed at paragraph 12. A new miniature relay fitted in the vehicle engine bay and wired as shown in Figure 5, replaces the original relay.

UNCONTROLLED IF PRINTED

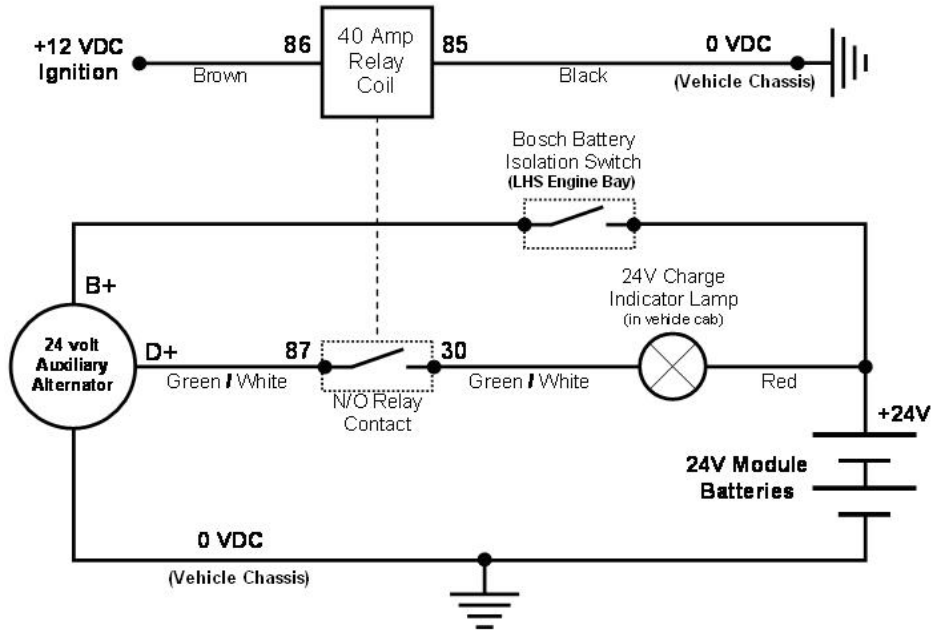

Figure 5 24-volt Auxiliary Alternator Charge Indicator Lamp Relay Circuit

13. Install the new charge indicator lamp relay as follows:
- Identify where the 12-volt ignition wire (it could be either brown or blue) cut from the Junction Box in paragraph 12.h. enters the engine bay wiring loom (Figure 6).



Figure 6 12-volt Ignition Wire - Engine Bay End

- Ensure that the wire is free of all cable ties or other fixings under the vehicle.
- Pull the wire back into the engine bay.

NOTE

This wire will be cut and connected to connector 86 on the new relay coil later in this procedure.

- Identify a suitable location on the left hand wheel arch in the engine bay to mount the new relay.

NOTE

Use Figure 7 as a location guide. A suitable mounting hole may be available on some vehicles. If required, mark and drill an 8 mm hole through the guard arch at the selected location.

UNCONTROLLED IF PRINTED



Figure 7 Engine Bay Mounting Location for the New Relay

- e. Mount the Hella 12-volt automotive relay (Table 1, Item 3) using an M6 x 20 mm bolt (Table 1, Item 6), M6 flat washer (Table 1, Item 10) and an M6 self-locking nut (Table 1, Item 8). Fit the washer and nut on the underside of the wheel arch.
- f. Hand-tighten the mounting bolt until all the wiring connections to the relay have been completed.
- g. Cut the brown ignition wire drawn back into the engine bay in paragraph 13.c. so that the length of wire still attached to the vehicle loom is long enough to connect to the relay in its mounted position.
- h. Fit an insulated quick connect terminal (Table 1, Item 13) and connect the wire to terminal 86 on the relay.
- i. Identify the red (B+) wire and the green/white (D+) wires (Figure 8) that are sheathed together and connected to the 24-volt auxiliary alternator in the engine bay.

NOTE

The auxiliary alternator is mounted below the 12-volt vehicle alternator on the LHS of the engine.

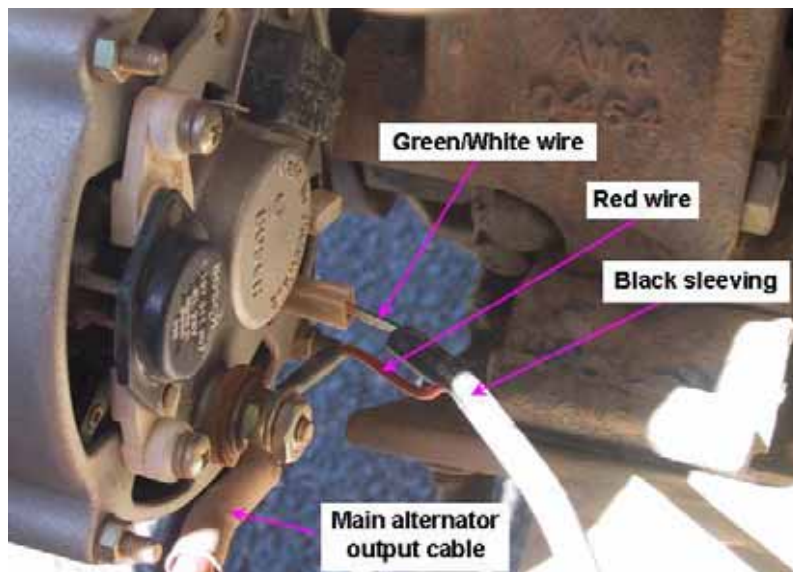

Figure 8 24-volt Auxiliary Alternator Connections

- j. Follow the black sleeving covering these two wires back from the alternator to a point adjacent to the new relay.

UNCONTROLLED IF PRINTED

- k. Carefully cut the outer sleeve only at this point and slide the two ends of the sleeving apart about 40 mm.

CAUTION

Ensure that the wire length from the alternator to the relay in its mounted location has sufficient slack in it to allow for engine movement.

- l. Cut the green/white wire in the middle of the exposed section and fit an insulated quick connect terminal (Table 1, Item 13) to both ends.
- m. Connect these two connectors to terminals 87 and 30 on the relay so that the relay contacts are now in series with the wire (Figure 5).
- n. Cut a length of 4 mm² black wire (Table 1, Item 18) long enough to connect between the forward mounting bolt of the Bosch battery isolation switch mounted on the left hand chassis rail and the new relay mounted on the guard arch.
- o. Fit an M10 insulated ring terminal (Table 1, Item 12) on one end of the wire and an insulated quick connect terminal (Table 1, Item 13) to the other end.
- p. Connect the ring terminal end of this wire to the isolation switch mounting bolt as shown in Figure 9.

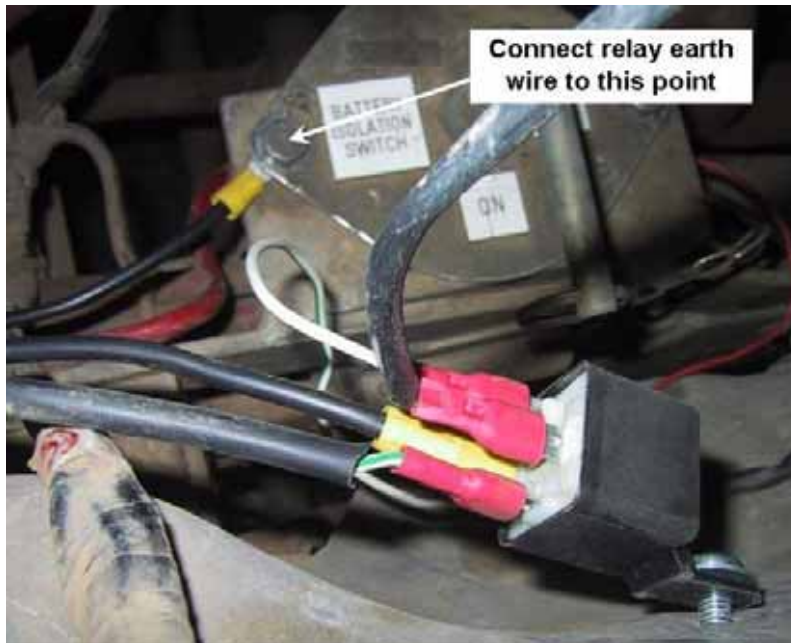

Figure 9 New Relay Ground Connection Point

- q. Connect the other end of the wire to terminal 85 on the relay.

NOTE

All the new relay wiring connections are now complete.

- r. Check all the connections and then tighten the relay mounting bolt with the terminals facing down (Figure 7).
- s. Ensure that all wiring is routed clear of sharp edges and moving parts.
- t. Secure wiring with cable ties (Table 1, Item 21) as required.

Installation of the Module Battery Isolation Switch

NOTE

The new module battery isolation switch is to be fitted above and to the left of the module battery carrier so that its T-bar handle can be easily reached and operated when the battery carrier is in the fully retracted position and the battery cover is fitted. The switch is a twist-to-operate double pole type with a T-bar operating handle that enables both the 12-volt and the 24-volt dc supplies to be isolated from the maintenance module wiring as illustrated in the wiring diagram shown in Figure 10.

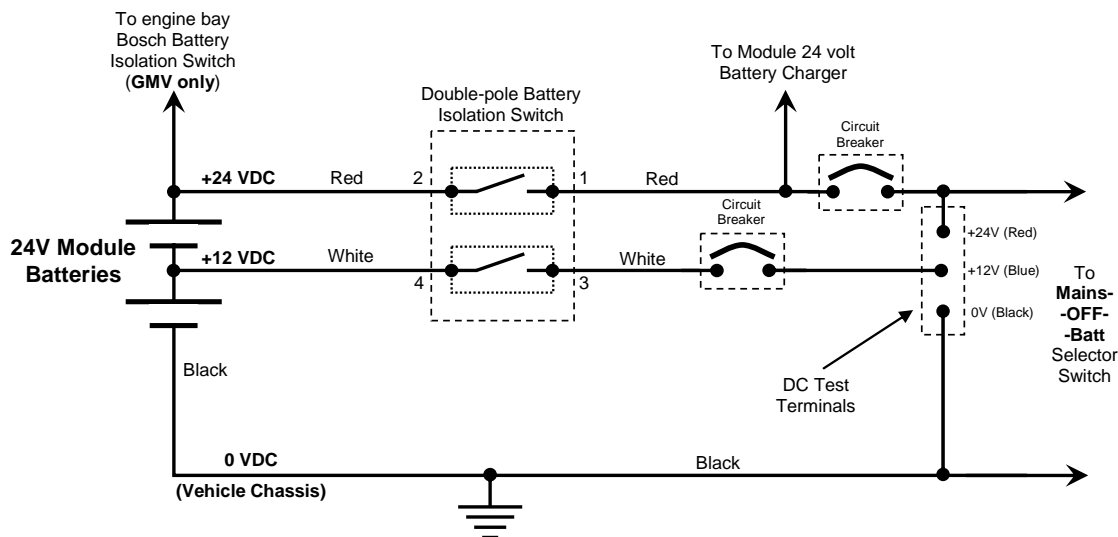

Figure 10 Wiring Diagram Showing the New Module Battery Isolation Switch

14. Install the module battery isolation switch as follows:
 - a. Mark and drill two 8 mm holes through the front left hand floor section of the module as shown in Figure 11.



Figure 11 Location of the Isolation Switch Mounting Bracket Holes

- b. Cut 50 mm off the short leg of each of the two isolation switch mounting brackets (Table 1, Item 4) as shown in Figure 12.
- c. Position the two isolation switch mounting brackets beneath the module floor over the holes drilled in para 14.a. with the long legs facing down and as close as possible to the angle frame member below the floor (Figure 13).
- d. Secure the brackets with an M8 x 40 mm button head bolt (Table 1, Item 5) and an M8 self-locking nut (Table 1, Item 7). Fit an M8 flat washer (Table 1, Item 9) beneath both the head of the bolt and the nut.

UNCONTROLLED IF PRINTED

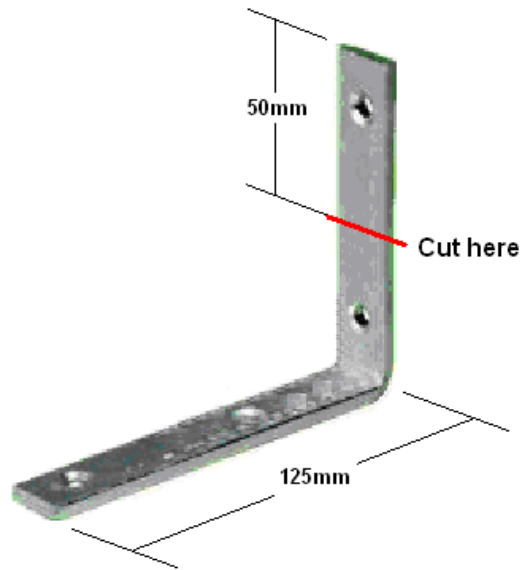

Figure 12 Mounting Brackets



Figure 13 Isolation Switch Mounting Brackets Fitted

- e. Identify the conduit cut from the junction box assembly in para 12.f. that contains a red, a white and a black white running back into the module body.
- f. Cut back the outer conduit to expose approximately 100 mm of the wires.
- g. Slip a short length of heatshrink tubing (Table 1, Item 15) over each wire and then fit M10 ring terminals (Table 1, Item 11) to the ends of both the red and the white wire as shown in Figure 14. Apply heat to shrink the tubing around the cable and the neck of each ring terminal.

UNCONTROLLED IF PRINTED



Figure 14 Module Wiring To Switch Connection Points

- h.** Connect the red wire (24-volt circuit) to terminal post 1 on the isolation switch (Table 1, Item 2) and the white wire (12-volt circuit) to terminal post 3 on the isolation switch (Figure 15).
- i.** The green/white wire shown in Figure 14 is no longer used. Wrap the cut end in a small piece of electrical tape and fold the end back into the flexible conduit.



Figure 15 Isolation Switch Connections

- j.** The black wire shown in Figure 14 must be lengthened enough to reach the ground terminal (0 volts) on the module batteries with the battery carrier in the fully extended position. Cut a length of 4 mm² black wire (Table 1, Item 16) and join it to the existing black wire with a sleeve type cable connector (Table 1, Item 14). Apply a short length of heatshrink tubing (Table 1, Item 15) over the finished joint.
- k.** Cut the extended black wire to length so that it can easily reach the ground terminal (0-volts) on the module batteries with the battery carrier fully extended (Figure 16). Slip a short length of heatshrink tubing (Table 1, Item 18) over the wire and then fit an M8 ring terminal (Table 1, Item 11) to the end. Apply heat to shrink the tubing around the cable and the neck of the ring terminal.

UNCONTROLLED IF PRINTED

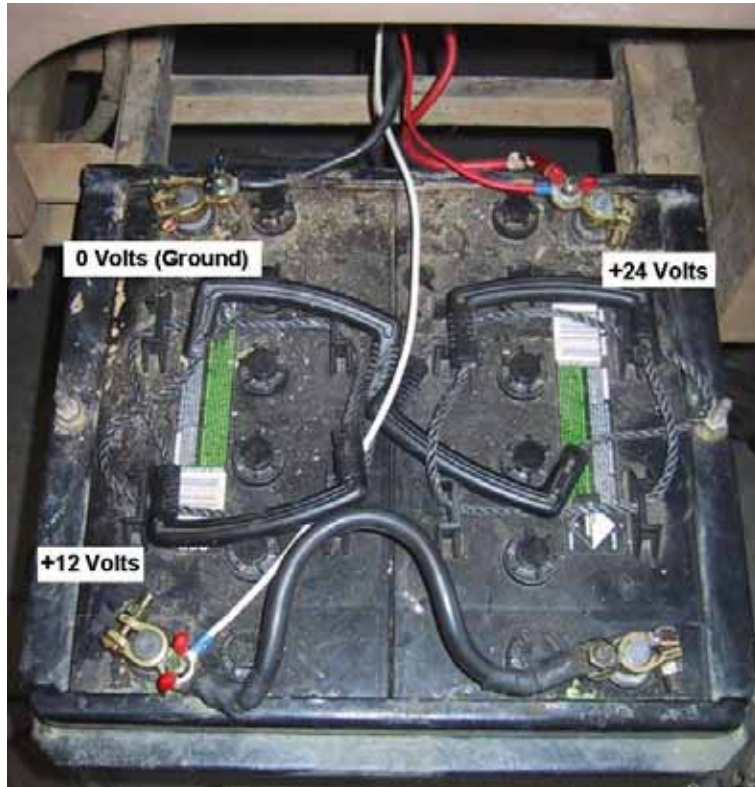

Figure 16 Module Battery Connections

CAUTION

Ensure there is enough slack in these two wires so that they are not stressed when the battery carrier is fully extended.

- i. With the battery carrier fully extended, cut a length of 4 mm² white wire (Table 1, Item 17) long enough to reach from the isolation switch (in its mounted position) to the 12-volt connection point on the batteries and a length of 4 mm² red wire (Table 1, Item 16) long enough to reach from the isolation switch to the 24-volt connection point on the batteries (Figure 16).
- m. Slip two short lengths of heatshrink tubing (Table 1, Item 15) over each length of wire and fit a yellow M8 ring terminal (Table 1, Item 11) to one end and a yellow M10 ring terminal (Table 1, Item 12) to the other end of each wire. Apply heat to shrink the tubing around the cable and the neck of each ring terminal.
- n. Connect the M10 end of the red wire to terminal post 2 (the 24-volt side) (Figure 15)
- o. Connect the M10 end of the white wire to terminal post 4 (the 12-volt side) on the isolation switch (Figure 15).
- p. Install the isolation switch onto the mounting brackets using two M8 x 40 mm bolts (Table 1, Item 5), two M8 flat washers (Table 1, Item 9) and two M8 self-locking nuts (Table 1, Item 7).
- q. Ensure that all wires and connectors are clear of sharp edges and that the 'live' terminals on the back of the switch are well clear of all earth points.
- r. Secure cables as required with cable ties (Table 1, Item 21) to ensure that wiring remains clear of pinch points and sharp edges when the battery carrier is moved from the extended to the closed position.

NOTE

The installed isolation switch is illustrated in the OFF position in Figure 17. The switch is turned ON by rotating the T-bar handle 90 degrees clockwise.



Figure 17 Installed Module Battery Isolation Switch (Shown in the OFF Position)

- s. Connect the red (24-volt) and black (ground) high current alternator cables (these cables were disconnected from the jumper terminals box at paragraph 12.e.) to the battery 24-volt and ground (0-volts) terminals respectively (Figure 16). Where required, fit new battery terminal assemblies (Table 1, Item 20) to the batteries to provide the wing nut tightened connecting points as shown in Figure 16.
- t. Connect the M8 ring terminal on the black wire (lengthened in paragraph 16.j.) to the battery ground (0-volts) terminal.
- u. Connect the M8 ring terminal on the white wire (from terminal 4 on the isolation switch) to the 12-volt battery terminal (Figure 16).
- v. Connect the M8 ring terminal on the red wire (from terminal 2 on the isolation switch) to the 24-volt battery terminal (Figure 16).
- w. Refit the battery cover.
- x. Slide the carrier back into the retracted position and secure it with the locking pin.

Installation of the Module Modification Record Plate

15. Position and secure the modification record plate (Table 1, Item 19) inside the maintenance module in the clear area on the upper right corner of the front interior wall (Figure 18).

NOTE

The plate is to be fixed with pop-rivets (preferred) or self tapping screws. If the plate supplied is of the self adhesive type, ensure that the selected area of the wall is cleaned with solvent before the plate is pressed into position.

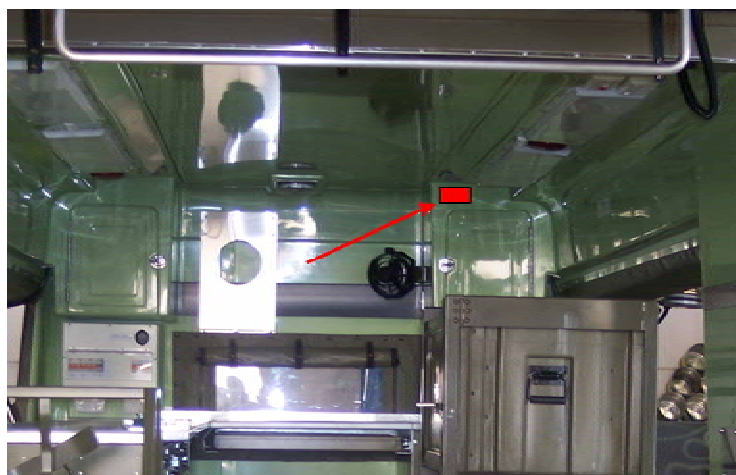

Figure 18 Location of the Modification Plate

POST MODIFICATION TESTING

Auxiliary Alternator Circuit Tests.

16. Proceed with the following tests:
- a. Ensure that the Bosch battery isolation switch located in the lower left-hand side of the engine bay is in the ON position.
 - b. Ensure that the newly installed module battery isolation switch is in the OFF position (the T-bar handle is in a horizontal position).
 - c. Reconnect the negative lead on the main vehicle battery.
 - d. Turn the vehicle ignition on, but do not start the engine.
 - e. The auxiliary alternator charge indicator lamp on the dash in the vehicle cabin should light and remain on.
 - f. Start the engine and allow it to idle.
 - g. Increase the engine revs slightly to excite the alternator.
 - h. The auxiliary alternator charge indicator lamp should now be extinguished.
 - i. Set the hand throttle so that the engine revs are sufficiently above idle for the charge indicator lamp to remain extinguished.
 - j. Use a dc voltmeter to check the voltage between the ground and 24-volt terminals on the module batteries (Figure 16). When the auxiliary alternator is charging the batteries, the voltage across the terminals should be approximately 27 volts.
17. If the above tests are not satisfactory, check the following:
- a. correct operation of the new charge indicator lamp relay in the engine bay - the relay should be energised (an audible click) when the vehicle ignition is turned on; and
 - b. correct operation of the auxiliary alternator charge indicator lamp - the lamp should light if the two green/white wires connected to the relay are manually joined together.

Module Isolation Switch Tests

18. Proceed with the following tests:
- a. Check that the module batteries are partially or fully charged - use a dc voltmeter to check that the voltage between the ground (0-volts) and 24-volt terminals on the module batteries is at least 24 volts dc when the engine is not running.
 - b. Check that the newly installed module battery isolation switch is in the OFF position (the T-bar handle is in a horizontal position) (Figure 17).
 - c. Turn the 24-volt power selection switch in the maintenance module to the BATT position (the power selection switch is located on the circuit breaker and power selection panel mounted on the LHS of module front wall). The needle on the 20 to 32 volt voltmeter mounted on the same panel should not move from the rest position.
 - d. Turn the module battery isolation switch to the ON position (the T-bar handle is rotated 90 degrees clockwise to the vertical position). The module voltmeter should now indicate battery voltage.
 - e. Use a dc voltmeter to check the voltages on the 12-volt and 24-volt test terminals mounted on the right-hand side of the maintenance module front wall.

NOTE

This will ensure the wiring is correct and no connections have been reversed.

- f. Turn the module battery isolation switch back to the OFF position and check that zero volts is now present at the test terminals.

- 19.** If the above tests are not satisfactory, check the following:
- a.** the circuit breakers for both the 24-volt and 12-volt DC supplies on the circuit breaker and power selection panel mounted are closed;
 - b.** all wiring connections to the module batteries; and
 - c.** wiring to the isolation switch – the white wires (12-volt circuit) should be connected to terminals 3 and 4 on the switch, and the red wires (24-volt circuit) should be connected to terminals 1 and 2 on the switch.

20. Recording Action. On completion of the modification, the following action is to be taken in accordance with TRAMM, Volume 3, Section 2, Chapter 2, Annex D:

- a.** Deface the number 33 on the vehicle modification record plate.
- b.** Deface the number 1 on the new module modification record plate.
- c.** Complete the modification details in Part 3 of the GM 120 - Record Book for Service Equipment
- d.** Forward the modification completion details using form GM 119 - Advice of Change in Build State (TRAMM, Volume 3, Section 2, Chapter 3, Annex C) to:

ADFLM, Lt B Vehicles
LVSP0, DMO
DPM-7, Bourke ST
MELBOURNE VIC 3000

UNCONTROLLED IF PRINTED

END

Distribution List: **VEH G 20.3 – Code 2** (Maint Level)
(Sponsor: LV SPO, Light B Vehicle section)
(Authority: ECO LTB 026/06)