

TRUCK, UTILITY, LIGHTWEIGHT, MC2 LANDROVER 110 - ALL TYPES

FUSING OF ADDITIONAL CIRCUITS

MODIFICATION INSTRUCTION

Issue of this instruction is authorized by CONMEA

Introduction

1. This instruction details the fusing of the instrument light and inspection light socket circuits on all variants and on FFR variants the fitting of a grommet to the positive inspection socket and the fusing of the FFR lamp.

Note:

1. NSN/MPN and Designation used in this instruction were current at the date of issue. If twelve months or more have expired since issue, the NSN/MPN should be checked for supersession.

General

2. Estimated Modification Time. 1 hr (initial planning only).
3. Priority. Group 2.
4. Modification to be Applied to. All subject vehicles up to and including ARN 50343.
5. Items Affected. Instrument light, inspection light socket and FFR lamp circuits.
6. Action Required. By RAEME units authorised to carry out unit, field and base repairs.

TABLE 1 - STORES REQUIRED  
(To be demanded through Moorebank Logistic Group)

Item	NSN	Designation	Qty per Equip
1.	5920-66-128-6029	KIT, FUSE CABLE AND LABEL NON FFR VARIANTS COMPRISING ITEMS 3, 4, 5	1
2.	5920-66-128-6032	KIT, FUSE CABLE AND LABEL FFR VARIANTS COMPRISING ITEMS 3, 4, 5, 6, 7	1
3.	6150-66-128-6030	CABLE LINK FUSED, 15 AMP, INSPECTION SOCKET (JRA NO BYG 9119)	1
4.	6150-66-128-6031	CABLE LINK FUSED, 5 AMP, DIMMER SWITCH (JRA NO BYG 9120)	1
5.	7690-66-128-6035	LABEL (JRA NO BYG 9116)	1
6.	5920-66-128-6033	FUSE HOLDER COMPLETE WITH TERMINALS FFR LAMP (JRA NO BYG 9073)	1
7.	5920-99-767-2990	FUSE 5 AMP (JRA NO RTC 4497)	1

UNCONTROLLED WHEN PRINTED

TABLE 2 - STORES REQUIRED  
(To be demanded through normal supply channels)

Item	NSN/MPN	Designation	Qty per Equip
1.	GJ KIT, R 90-3	GROMMET, BLANKING, 12MM	1
2.	5975-00-111-3208	CABLE TIE	2

Detail

7. The modification is to be carried out as follows:
- a. Remove the passenger seat base and disconnect the battery.
  - b. Unscrew and remove the instrument dimmer switch cover panel (cargo) or upper instrument panel (FFR).
  - c. Inspect the dimmer switch for serviceability and ensure that the wiring has been modified in accordance with EMEI VEH G 197-3.
  - d. Disconnect the brown wire to the positive (red) inspection light socket.
  - e. On FFR variants:
    - (1) Undo the positive terminal securing nut and remove the terminal;
    - (2) Fit the grommet (item 1 from Table 2) to the terminal access hole and push the terminal through the centre of the blanking grommet; and
    - (3) Reassemble the terminal as shown in Fig 1.

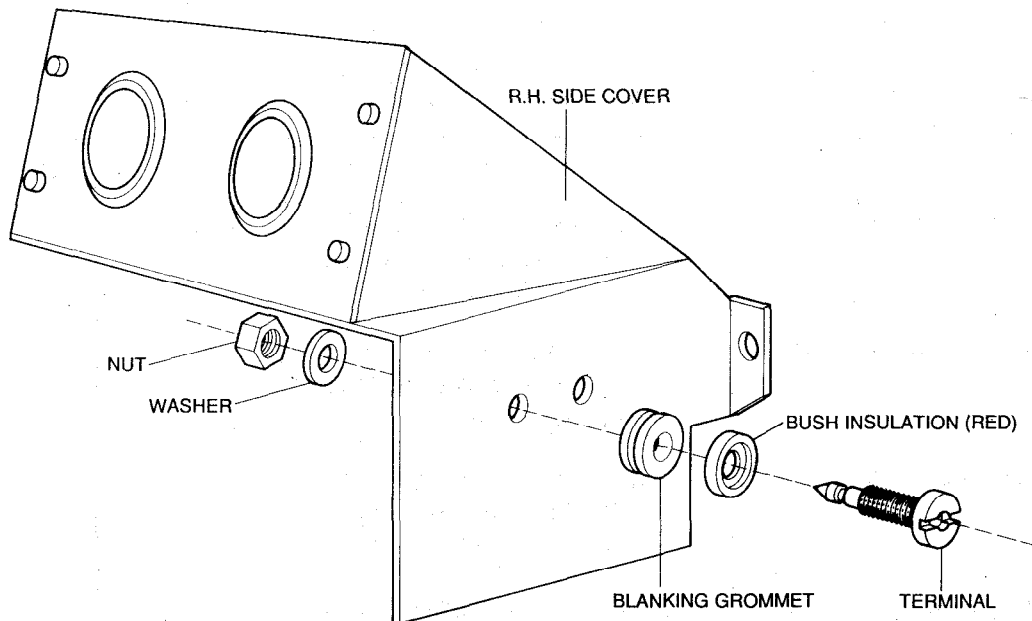

FIG 1 - TERMINAL ASSEMBLY

- f. Fit the 15 amp fused cable link (item 3 from Table 1) between the brown wire and the positive inspection socket terminal.

UNCONTROLLED WHEN PRINTED

- g. Remove the white cable that connects the dimmer switch to the main harness and replace it with the 5 amp fused cable link (item 4 from Table 1).
- h. Interlock the fuse holders with a cable tie (item 2 from Table 2).
- i. Attach the label (item 5 from Table 1) to the inside surface of the fuse cover as shown in Fig 2.
- j. Identify the brown wire with white ident, in the vicinity of the blackout switch, and ensure that the crimped connector on the wire is serviceable and fits securely into the connector on the brown/white wire.

Note:

- 1. These wires connect the main lighting switch to the blackout lighting switch.
- k. Refit the dimmer switch cover panel (cargo) or upper instrument panel (FFR).

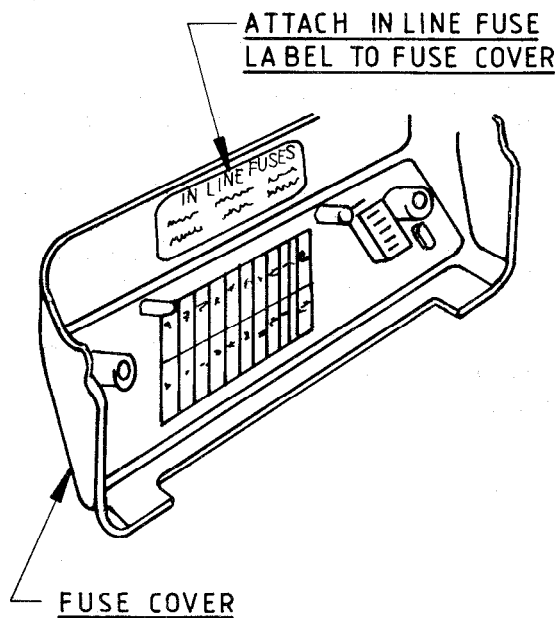

FIG 2 - FUSE COVER

- l. Reconnect the battery and check that the inspection socket and instrument dimmer switch function correctly.
- m. Refit the passenger seat base.
- n. On FFR variants:
  - (1) Disconnect the radio batteries.
  - (2) Identify the red wire, as shown in Fig 3, cut it near the FFR lamp and fit the fuse holder and crimp terminals (item 6 from Table 1) to the wire.

UNCONTROLLED WHEN PRINTED

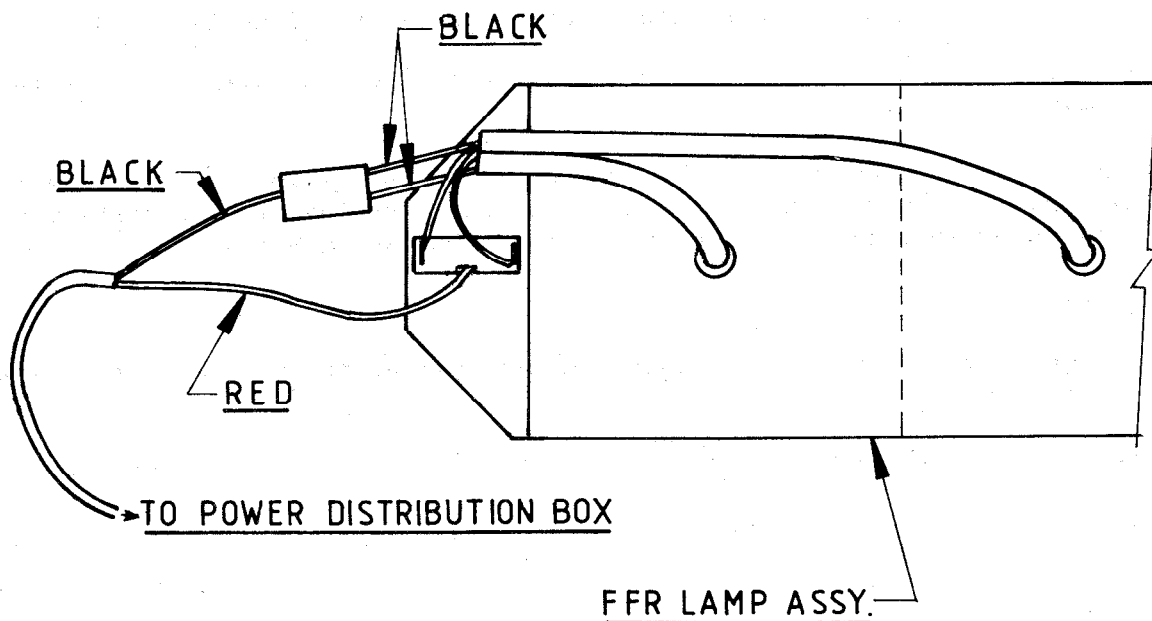

FIG 3 - FFR LAMP

(3) Fit a 5 amp fuse (item 7 from Table 1) to the holder and attach the holder to the loom with a cable tie (item 2 from Table 2).

(4) Reconnect the radio batteries and test the operation of the FFR lamp.

8. Modification Record Plate. Deface the numeral 10 on the modification plate located on the driver's seat base, including those vehicles modified in production.

9. Recording. Enter the details of the modification in Part 3 of the TGM 120, Record Book for Service Equipment, for the subject vehicles, including those vehicles modified in production.

E N D