

TRUCK UTILITY LTWT MC2 LANDROVER (110) - ALL TYPES

FITTING OF HEATER CABLE SECURING STRAPS

MODIFICATION INSTRUCTION

Issue of this instruction is authorized by CONMEA.

Introduction

1. This instruction details the securing of the heater control cables to the vehicle firewall to prevent the cables from rubbing through on the air cleaner securing straps.

Note:

1. NSN and Designation used in this instruction were current at the date of issue. If twelve months or more have expired since issue, the NSN should be checked for supersession.

General

2. Estimated Modification Time. 0.15 (Initial planning only).
3. Priority. Group 2.
4. Modification to be Applied to. All subject vehicles.
5. Items Affected. Heater cables.
6. Action Required. By RAEME units authorized to carry out unit, field or base repair in accordance with WKSP A 850.

TABLE 1 - STORES REQUIRED (To be demanded through Moorebank Log Gp)

Item	NSN	Designation	Qty per Equip
1.	2590-97-121-2701	Modification Kit (BYG 2044) consists of:	
2.	5340-66-106-1527	CLAMP LOOP (C393771L)	1
3.	5975-99-787-7254	STRAP LH (AAU 3686)	1

Detail

8. The modification is to be carried out as described below:
  - a. Unscrew Item 17 as shown in Fig 1 and retain it.

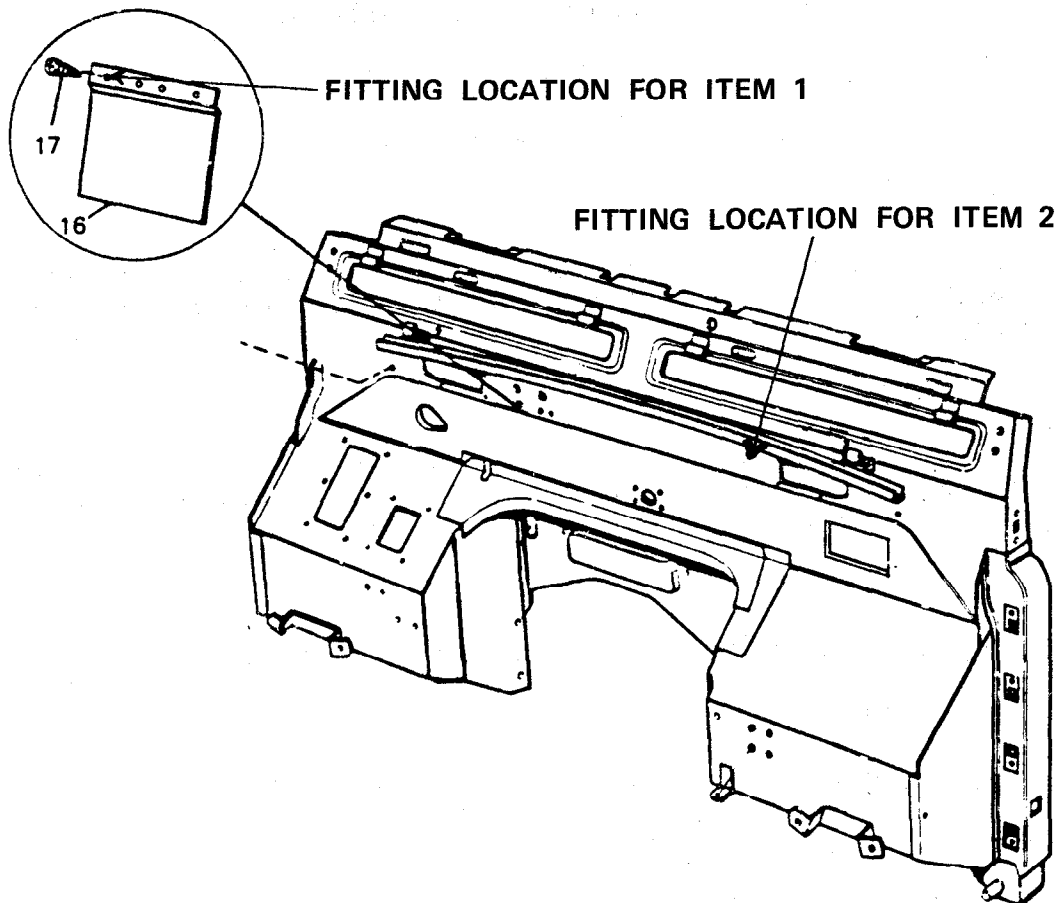

FIG 1 - LOCATION OF PROTECTION PLATE

- b. Remove the cable ties securing the heater cables to the air cleaner assembly securing bands and discard them.
- c. Loop Item 1 from Table 1 around the heater cables ensuring the stepped end of the clamp is furthest away from the scuttle (firewall) and the tail of the clamp is pointing downwards.
- d. Refit screw on washer previously removed, into the clamp recess and secure the clamp. DO NOT TIGHTEN AT THIS STAGE.
- e. Locate the hole on the scuttle adjacent to the LH grommet plate as shown in Fig 1.
- f. Position Item 2 from Table 1 into the hole and lightly tap the locking block fully home.
- g. Secure the heater cables to the strap.
- h. Pull down on the tail of the Clamp Loop (item 1) and tighten the retaining screw.

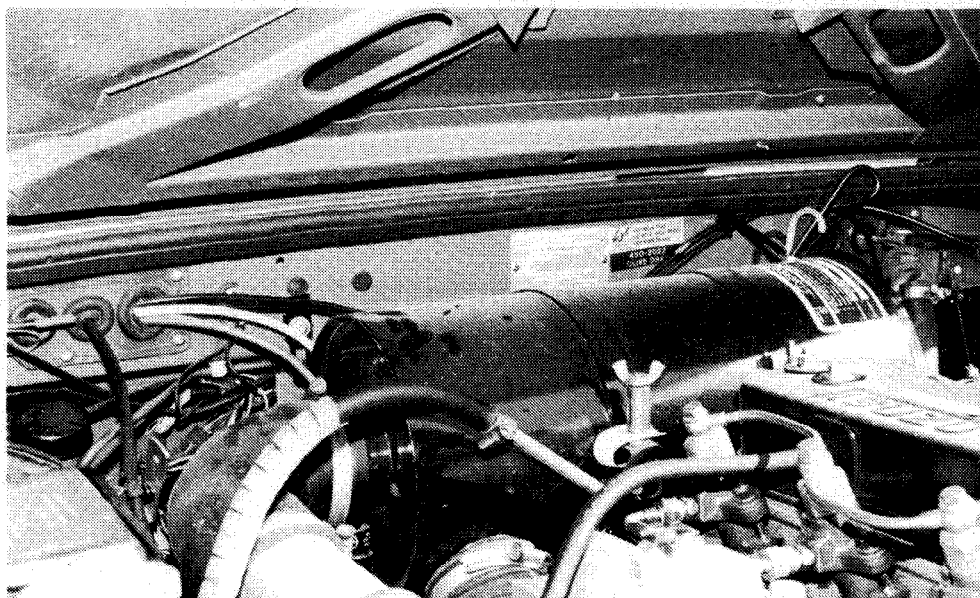

FIG 2 - COMPLETED MODIFICATION

Modification Record Plate

9. On completion of the modification, deface the numeral 6 on the modification record plate located on the drivers seat base.

Recording

- 10 Details of the modification are to be entered in the TGM 120 Record Book for Service Equipment.

Note:

1. Those vehicles which have previously been modified during production are to have the modification plates defaced and recorded in accordance with para 9 and 10 of this instructon.

E N D