

TRUCK, LIGHTWEIGHT, MC2, LAND ROVER 110 4X4 - ALL TYPES

FITTING OF COIL SPRING RETAINERS

MODIFICATION INSTRUCTION

This instruction is authorised for use by command of the Chief of the General Staff. It provides direction, mandatory controls and procedures for the operation, maintenance and support of equipment. Personnel are to carry out any action required by this instruction in accordance with GENERAL A 001.

Introduction

1. This instruction details the fitting of retainers to the coil spring seats to prevent dislodgment of the springs from their seats during cross country operations. A retainer is fitted to the front lower seat, a strap to the rear upper seat and a thicker retainer to the rear lower spring seats of all Land Rover 110 variants, including Truck Surveillance Lightweight, Land Rover 110 4x4 (RFSV). In addition retainers are fitted to the rear inner spring upper seats on RFSV only.

General

2. **Associated Publications.** The latest issue of the following references should be read in conjunction with this instruction:

- a. EMEI Workshop A 850 - Modifications, Trial Modifications and Local Modifications to Equipment;
- b. EMEI Workshop A 851 - Modifications to Equipment - Use of Modification Record Plates and Documentary Requirements;
- c. HQ Logistic Command Equipment Maintenance Programme (EMP) 23/93 - Fitting of Coil Spring Retainers - all Land Rover 110 4x4 variants, including RFSV; and
- d. HQ Logistic Command EMP 9/93 - Fitting of Rear Inner Spring Upper Seat Retainers - RFSV only.

3. **Authority.** Rover Australia Engineering Changes 2223 and 2257.

4. **Modification Application.** All Land Rover 110 4x4 variants.

5. **Items Affected.** Items affected are:

- a. all Land Rover 110 4x4 variants, including RFSV - front lower spring seat, rear spring upper and lower seats; and

b. RFSV only - rear inner spring upper seat.

6. **Priority - Group 1.** Continued operation of vehicles is authorised provided that:

- a. The parts kit (item 1 in Table 2) is ordered on receipt of this instruction, as detailed in HQ Log Comd EMP 23/93, for all Land Rover 110 4x4, including RFSV.
- b. The modification detailed in paragraphs 11 and 12 is completed within 20 working days of the receipt of stores in the owner unit;
- c. RFSV are booked into supporting Rover Australia dealers for the warranty action detailed in paragraph 13 and the repair completed within 20 working days of the receipt of stores in units; and
- d. The springs are inspected weekly to ensure correct positioning on the seats, until the modification is completed.

7. **Action Required.** Action required is:

- a. The modification detailed in paragraphs 11 and 12, is to be performed by RAEME units or sub units authorised to carry out unit, field or base repairs; and
- b. The modification detailed in para 13 is to be carried out by Rover Australia dealers, as a warranty repair, as detailed in Rover Australia Service Newsletter Military 07/1992.

8. **Estimated Manhours to Perform.** For initial planning purposes only, it is estimated that this modification will take 1.30 manhours to perform. This does not include repair times for RFSV which is a warranty repair to be carried out by Rover dealers.

9. **Items to be Removed.** The items to be removed are detailed in Table 1 and are to be disposed of as detailed in GENERAL P series.

10. **Stores Required.** The stores required are listed in Table 2 for all variants and Table 4 for RFSV only. HQ Log Comd EMP 23/93 and 9/93 detail the issue of parts kits. A summary of the EMP follows:

- a. EMP 23/93 controls the issue of the parts kit (item 1 from Table 2) and the kit is to be ordered from Moorebank Log Gp on the basis of one kit per vehicle.
- b. Each indent is to list the ARNs of the vehicles for which the order is placed.
- c. Kits are not to be ordered for stock and are not to be procured locally.

- d. The remaining items in Table 2 (items 2 and 3) are to be ordered through normal supply channels.
- e. Table 3 shows the breakdown of the parts kit (item 1 in Table 2) to assist component identification and the parts are not to be ordered to complete the modification.
- f. EMP 9/93 controls the issue of the parts kit (item 1 from Table 4) and the kit is to be ordered from Moorebank Log Gp by units holding RFSV on the basis of eight retainers per vehicle.

Table 1 - Stores to be Removed

Item	Mfr Part No	Designation or Description	Unit of Issue	Qty per Equip
1.	NRC4318	Retainer, Rear Spring Lower, 175 mm lg,	ea	23 mm thick

Table 2 - Stores to be Ordered to Complete the Modification - All Land Rover 110 4x4 Variants

Item	NSN	Mfr Part No	Designation or Description	Unit of Issue	Qty per Equip
1.	2540-97-121-3144	AYG7458	Kit, Coil Spring Retainer, detailed in HQ Log Comd EMP 23/93, comprising items 1 to 4 in Table 3		1.6
2.			Primer Coating, metal, Zinc Rich Epoxy		
a.	8010-66-052-4628		1 litre can, or	1 Lt	1
b.	8010-66-052-4629		4 Litre can	4 Lt	1
3.	3439-66-016-2219		Electrode, Welding, Mild Steel	5 Kg	1

Table 3 - Stores Contained in Modification Kit (to assist parts identification and not to be ordered to the complete modification)

Item	Mfr Part No	Designation or Description	Unit of Issue	Qty per Equip
1.	AYG4352	Spring Retainer, Front Lower Seat	ea	2
2.	AYG7439	Limit Strap, Rear Tower Top	ea	2
3.	AYG7441	Spring Retainer, Rear Lower Seat, 175 mm lg, 5 mm thick	ea	2
4.	-	Installation Drawing, DOI-Y-830	ea	1

Table 4 - Stores to be Ordered as Detailed in HQ Log Comd EMP 9/93 For RFSV Only

Item	NSN	Mfr Part No	Designation or Description	Unit of Issue	Qty per Equip
1.	2540-97-121-3171	HYG6098	Rear Inner Spring Upper Seat Retainer, required for HQ Log Comd EMP 9/93	ea	8

UNCONTROLLED WHEN PRINTED

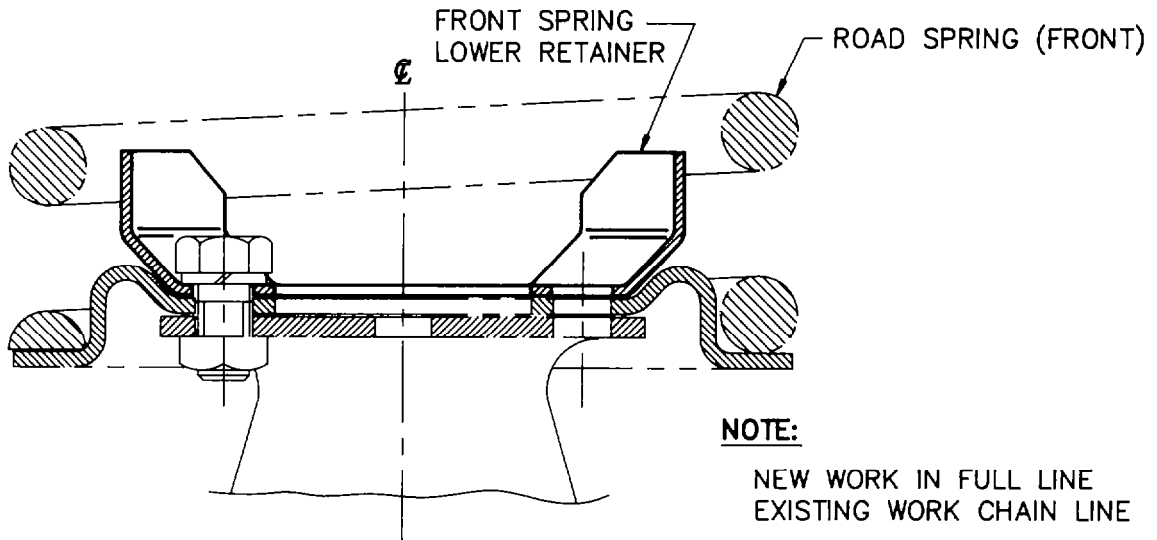

Figure 1 - Front Lower Spring Seat Retainer

**MODIFICATION OF SPRING SEATS - ALL
LAND ROVER 110 VARIANTS**

Front Spring Lower Retainers

11. Proceed as follows with reference to Figure 1 for the retainer position:

- a. Remove the nuts, cup washers, rubber bushes and sealing washers securing each front shock absorber to the axle casing and raise the shock absorbers.
- b. Remove the lower spring seat retaining bolts, pass the new lower retainers (item 1 from Table 3) through the spring coils and using the seat retaining bolts secure the retainers to the spring seat.
- c. Install the rubber bushes, cup washers and seating washers to the shock absorbers and secure the shock absorbers to the axle casing.

Rear Spring Upper and Lower Seats

12. Proceed as follows:

- a. Position the rear upper spring seat retainers (item 2 from Table 3) as shown in Figure 2, mark the outline of the bracket and remove all traces of galvanising from the marked area and for 2 cm surrounding.
- b. Weld the upper spring seat retainers in place as shown in Figure 2.

c. Paint the exposed weld area with cold gal (item 2 from Table 1).

d. Remove the existing rear lower spring seat retainers and fit new retainers (item 3 from Table 3) ensuring that the retainer clamps on the smallest part of the lower coil.

**MODIFICATION OF REAR INNER SPRING
UPPER SEATS - RFSV ONLY**

13. The modification to the rear inner spring upper seats is to be carried out by Rover Australia dealers as a warranty repair as detailed in Rover Australia Newsletter Military 07/1992. EMP 9/93 controls the issue of parts and details action required. Figure 3 depicts the modified upper spring seat, for information.

14. **Post Modification Testing.** Road test the vehicle and check all new components for security.

15. **Recording Action.** On completion of the modification:

- a. Deface the number 25 on the modification plate located on the drivers seat base;
- b. Enter the details of the modification in Part 3 of the GM 120, Record Book for Service Equipment, for the subject vehicles; and
- c. Report the completion of the modification to the Regional Fleet Managers as detailed in HQ Log Comd EMP 9/93 and 23/93, as applicable.

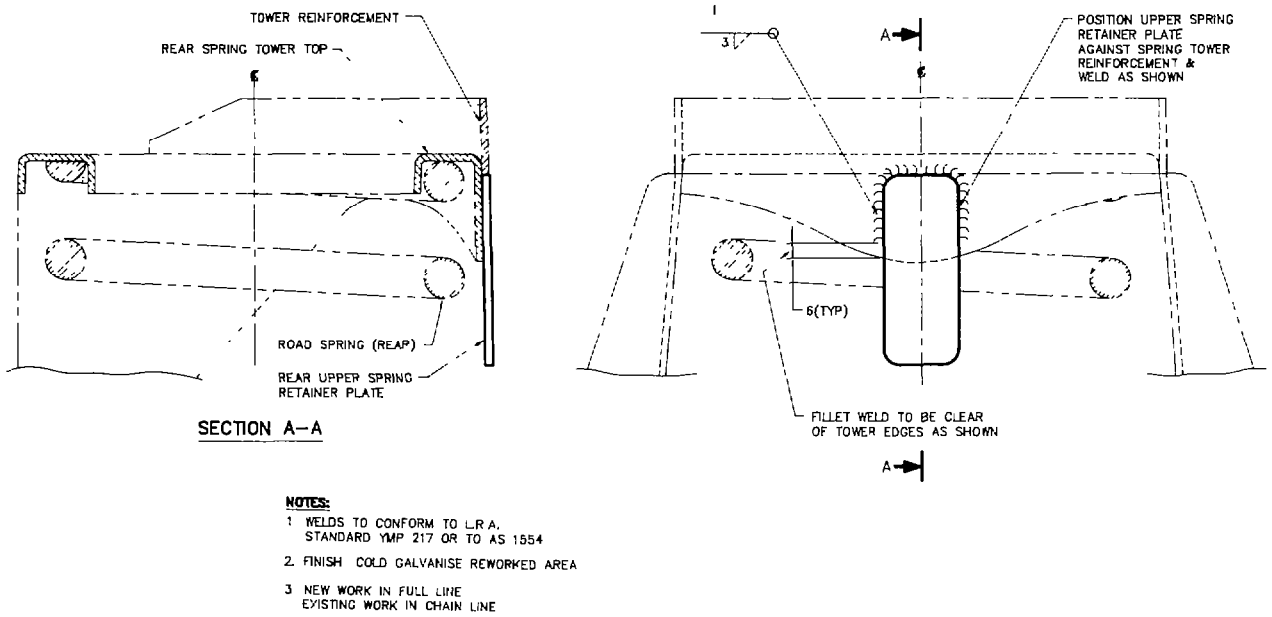

Figure 2 - Rear Upper Spring Seat Retainer

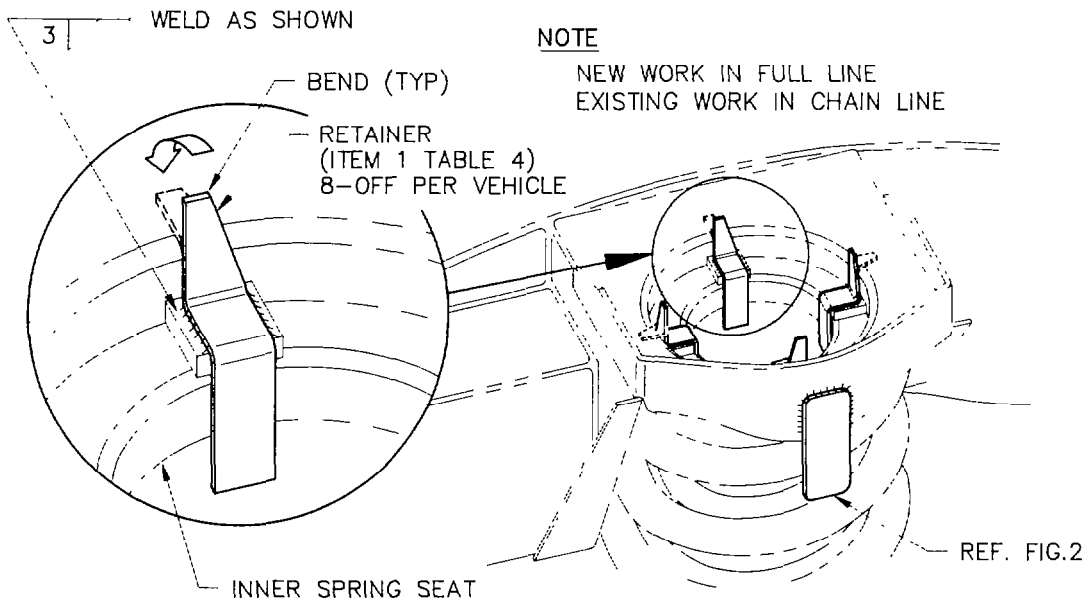

Figure 3 - Modified Rear Inner Spring Upper Seat RFSV only

UNCONTROLLED WHEN PRINTED