

TRUCK, PANEL, LIGHTWEIGHT, SURVEY, FFR, WINCH, MC2 — LAND ROVER 110

LIGHT GRADE REPAIR

This instruction is authorised for use by command of the Chief of Army. It provides direction, mandatory controls and procedures for the operation, maintenance and support of equipment. Personnel are to carry out any action required by this instruction in accordance with EMEI General A 001.

TABLE OF CONTENTS

	Page No		Page No
Introduction	3	Interior Lamps	11
Associated Publications	3	Interior Lamps Switch	11
Location Of Identification Numbers	4	Batteries (28 Volt Installation)	12
List Of Lubricants	5	Electrical System (28 Volt) Fault Finding	13
Engine – Group 1	5	Hour Meter Or Amp Gauge Replacement	14
Jockey Pulley	5	Forced Air Ventilator	14
Cooling System – Group 2	6	Fan Control Switch	16
Fanbelts	6	Air Filter	16
Engine And Cooling Group Specifications	7	Body – Group 17	18
Electrical – Group 15	8	Rear Door	18
Alternator (28 Volt)	8	Rear Door Glass	18
Wiring Harness	9		

LIST OF FIGURES

	Page No		Page No
Figure 1 Jockey Pulley Exploded View	5	Figure 8 Instrument Panel Removal	14
Figure 2 Fanbelt Replacement	7	Figure 9 Forced Air Ventilator Removal	15
Figure 3 Alternator Installation	8	Figure 10 Fan Motor Removal	15
Figure 4 Rear Wiring Harness (FFR)	10	Figure 11 Ducting Door Opening	17
Figure 5 Batteries Installation	10	Figure 12 Air Filter Removal	17
Figure 6 Interior Lamps Exploded View	11	Figure 13 Rear Door Removal	18
Figure 7 Left Side Battery Compartment	12	Figure 14 Rear Door Glass Removal	19

LIST OF TABLES

	Page No		Page No
Table 1 Location of Identification Numbers	4	Table 3 Engine And Cooling Group Specifications	7
Table 2 List of Lubricants	5	Table 4 Electrical System (28 Volt) Fault Finding	13

UNCONTROLLED IF PRINTED

UNCONTROLLED IF PRINTED

Blank Page

INTRODUCTION

1. This EMEI contains procedures for removing, dismantling, repairing, assembling and installing various components of the Truck, Panel, Lightweight, Survey, Fitted For Radio, with winch. Where applicable, instructions for the adjustment, lubrication and minor servicing of these items are included.



Do not use adhesive tapes to seal fuel or oil openings. The adhesive tape is soluble in fuel or oil and can cause contamination. Remove temporary covers before assembling.

2. Prevent dirt and foreign objects from entering any component by placing clean temporary coverings over all exposed openings, including hoses, tubes and lines.

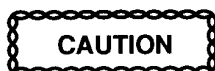

Before removing any electrical system components, disconnect the battery leads.

3. When disconnecting electrical connectors, hoses and fittings, remove clamps as required, to gain slack and avoid damage to connectors and fittings.

4. Discard all used gaskets, seals, cotter pins, tab washers, lock pins, key washers and lock washers. Discard all contaminated fuel and lubricants drained from the truck.

5. Use only those fuels and lubricants specified in the Servicing Instruction, EMEI Vehicle G 109, the User Handbook and this EMEI when replenishing fuel or lubricants.

6. Any fastenings or fittings being tightened to prescribed torques are to have dry, clean threads unless otherwise specified. When specified, thread sealants are to be applied to dry, clean, oil free threads.

7. The engine cooling system contains Nalcool corrosion inhibitor in water at a ratio of 1:12.



Precautions should be taken prior to carrying out repairs which include painting, sanding, scraping or welding. Refer to EMEI Workshop D 701 – Repair Policy for Equipment Painted in Polyurethane Paint.

8. This vehicle is painted in polyurethane paint.

Associated Publications

9. Reference may be necessary to the latest issue of the following documents:

- a. Defence Road Traffic Instructions;
- b. Complete Equipment Schedules (CES):
 - (1) SCES 12040.
 - (2) Equipment Kit SCES 12036.
- c. Block Scale 2406/31 – Special Tools for RAEME – B Vehicles – Truck Utility and Trucks, Light, MC2 (Land Rover Model 110);
- d. EMEI Electrical P 410 – Generator, Engine Accessory 28 Volt – 100 Ampere – Data Summary;
- e. EMEI Vehicle A 029 – Vehicles General – Servicing of B Vehicles, Trailers, Motorcycles, Stationary Equipment, Auxillary and Small Engines;
- f. EMEI Vehicle A 291-5 – General Service B Vehicles Tyre Guide – Operating Instructions;

- g. EMEI Vehicle G 103 – Truck, Utility, Lightweight , MC2, Land Rover 110 and Truck, Utility, Lightweight , W/Winch, MC2, Land Rover 110 – Light Grade Repair;
- h. EMEI Vehicle G 109 – Truck, Lightweight, MC2, Land Rover 110 4X4, All Types – Servicing Instruction;
- i. EMEI Vehicle G 120 – Truck, Panel, Lightweight, Survey, FFR, Winch, MC2, Land Rover 110 – Data Summary;
- j. EMEI Vehicle G 122 – Truck, Panel, Lightweight, Survey, FFR, Winch, MC2, Land Rover 110 – Technical Description;
- k. EMEI Vehicle G 124-1 – Truck, Panel, Lightweight, Survey, FFR, Winch, MC2, Land Rover 110 – Medium and Heavy Grade Repair;
- l. EMEI Workshop D 701 – Repair Policy for equipment Painted in Polyurethane Paint; and
- m. RPS 02192.

WARNING

All industrial safety, work practices and equipment operating and maintenance instructions pertaining to this EMEI are to be adhered to.

The handling, storage and use of chemical substances are to be in accordance with MOHS, MSDS and EMEI Workshop series requirements.

Location of Identification Numbers

10. The location of identification numbers on components of the vehicle is described in Table 1.

Table 1 Location of Identification Numbers

Serial	Identification Number	Location
1	Chassis number	Right hand side of the chassis, forward of the spring mounting turret
2	Chassis nameplate	Left hand seat box, in the cab
3	Engine number	Left hand side of the engine block
4	Injection pump identification	Side of the pump
5	Transmission and transfer case	Rear of the transfer case
6	Torque limiter	On rear end of the drive plate
7	Front axle number	Adjacent to the axle breather
8	Rear axle number	Adjacent to the axle breather

NOTE

NSN and Manufacturers part numbers and designations used in this EMEI were current at the date of issue. If twelve months or more have expired since issue, the NSN and Manufacturers part number should be checked for supersession.

UNCONTROLLED IF PRINTED

List of Lubricants

11. The list of lubricants is detailed in Table 2.

Table 2 List of Lubricants

Serial	Equipment	Lubricant	Capacity (litres)
1	Engine (including filter)	OMD-115	8.5
2	Transmission	OMD-115	2.7
3	Transfer case (with PTO)	OMD-115	5.8
4	Front differential	OEP-220	1.7
5	Rear differential	OEP-220	2.3
6	Swivel pin housings	Molytex Grease	EP00 Sachet
7	Brake master cylinder	OX (Aust) 8	Fill to level
8	Clutch master cylinder	OX (Aust) 8	Fill to level
9	Steering box	OEP-220	0.45
10	Fanbelt jockey pulley	XG-274	As required
11	Wheel bearings	XG-274	As required
12	Winch rope	Rocol wire rope lube NSN 9510-66-150-1763	As required
13	Radiator inhibitor	Nalcool	As required (1:12 ratio)
14	Propeller shaft	XG-274	As required
15	Winch drive line	XG-274	As required
16	Winch	OEP-220	1.3

ENGINE – GROUP 1

Jockey Pulley

12. **Removal.** Remove the jockey pulley as follows:

- a. Slacken the adjusting bolt on the pulley arm (refer Figure 1).

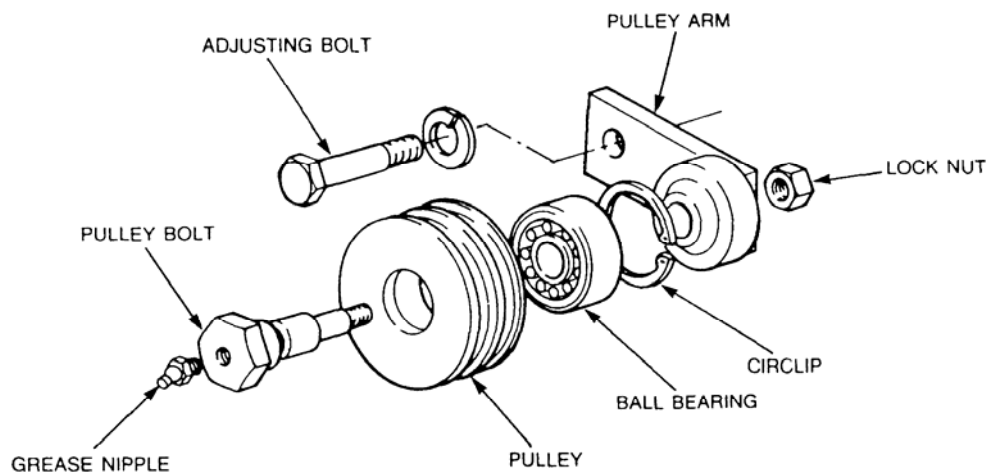

Figure 1 Jockey Pulley Exploded View

- b. Detach the two fanbelts from the pulley.
- c. Remove the adjusting bolt from the pulley arm and mounting.
- d. Remove the pulley arm and pulley from the engine.

UNCONTROLLED IF PRINTED

13. **Disassembly.** Disassemble the jockey pulley as follows:
- a. Remove the grease nipple from the pulley bolt.
 - b. Secure the pulley arm in a vice.
 - c. Remove and discard the lock nut securing the pulley bolt.
 - d. Remove the pulley bolt and pulley.
 - e. Remove the internal circlip retaining the bearing in the pulley.
 - f. Remove the bearing from the pulley.
 - g. Clean and degrease the pulley.

14. **Reassembly.** Reassemble the jockey pulley as follows:
- a. Install the bearing in the pulley.

NOTE

Ensure that the chamfered face is installed first.

- b. Insert the circlip into the pulley.
 - c. Install the pulley on the pulley arm with the circlip facing the arm boss.
 - d. Insert the pulley bolt and a new lock nut.
 - e. Install the grease nipple and lubricate with XG-274.
15. **Installation.** Install the jockey pulley as follows:
- a. Align the pulley arm bolt hole with the mounting hole.
 - b. Insert the adjusting bolt.
 - c. Fit the two fanbelts in the pulley grooves.
 - d. Position the pulley arm to allow a deflection of 5–10 mm on the longest span of the belts.
 - e. Tighten the adjusting bolt securely.

UNCONTROLLED IF PRINTED

COOLING SYSTEM – GROUP 2

Fanbelts

16. **Replacement.** Replace the fanbelts as follows:
- a. Slacken the adjusting bolt on the pulley arm (refer Figure 1).
 - b. Detach the two fanbelts from the pulley.
 - c. Remove the two 28 volt alternator fanbelts from the crankshaft pulley.
 - d. Loosen the 12 volt alternator mounting bolts and remove the adjusting bolt (refer Figure 2).

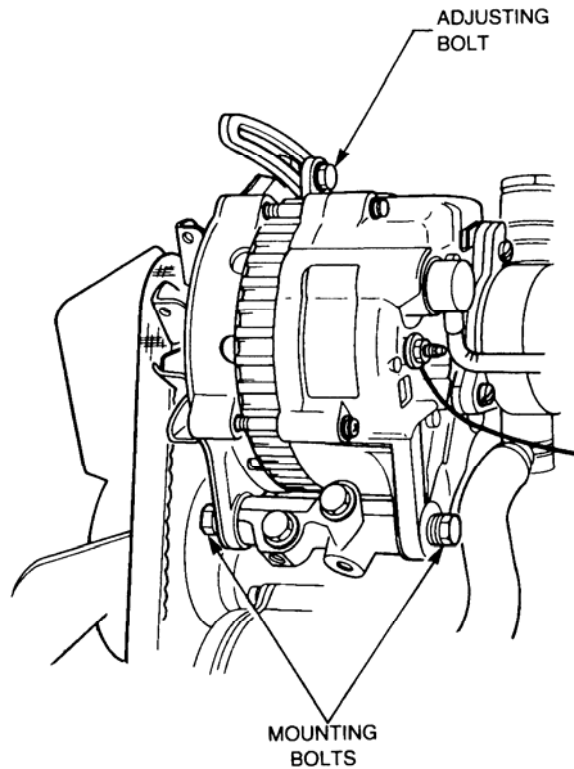

Figure 2 Fanbelt Replacement

- e. Detach the fanbelt from the 12 volt alternator drive pulley.
- f. Remove all three fanbelts from the engine.
- g. Install the inner fanbelt.
- h. Ensure that all three drive pulleys are correctly located.
- i. Swing the 12 volt alternator away from the engine.
- j. Check the tension of the belt by applying moderate thumb pressure to the longest span of the belt.
- k. When the belt deflection of 10–15 mm has been obtained, install and tighten the adjusting bolt.
- l. Tighten the mounting bolts.
- m. Install the remaining two fanbelts and ensure that the belts are correctly located on the pulleys.
- n. Position the pulley arm to allow a deflection of 5–10 mm on the longest span of the belts.
- o. Tighten the adjusting bolt securely.

Engine And Cooling Group Specifications

17. The engine and cooling group specifications are detailed in Table 3.

Table 3 Engine And Cooling Group Specifications

Serial	Description	Item	Specification
1	Fanbelt deflection	12 volt alternator	10–15 mm
		28 volt alternator	5–10 mm

UNCONTROLLED IF PRINTED

ELECTRICAL – GROUP 15

Alternator (28 volt)

18. **Removal.** Remove the 28 volt alternator as follows:
- Disconnect the vehicle and FFR system batteries.
 - Cut the lock wire securing the cannon plug to the 28 volt alternator.
 - Remove the cannon plug.
 - Slacken the adjusting bolt on the pulley arm (refer Figure 1).
 - Detach the two fanbelts from the pulley.

WARNING

The 28 volt alternator is heavy. Care must be taken when removing the 28 volt alternator or personal injury may result.

- Support the 28 volt alternator, then remove the two bolts that retain the 28 volt alternator clamp rings to the mounting.
- Carefully remove the 28 volt alternator from the vehicle.
- Discard the lock washers.
- Remove the four bolts, nuts and washers that secure the clamp rings on the 28 volt alternator.
- Remove the clamp rings.
- Discard the lock washers.

NOTE

Repair procedures for the 28 volt alternator are detailed in EMEI Electrical P 410 series.

19. **Installation.** Install the 28 volt alternator as follows:
- Fit the two clamp rings onto the 28 volt alternator and install the four bolts, nuts and washers (refer Figure 3).

NOTE

Do not tighten at this stage.

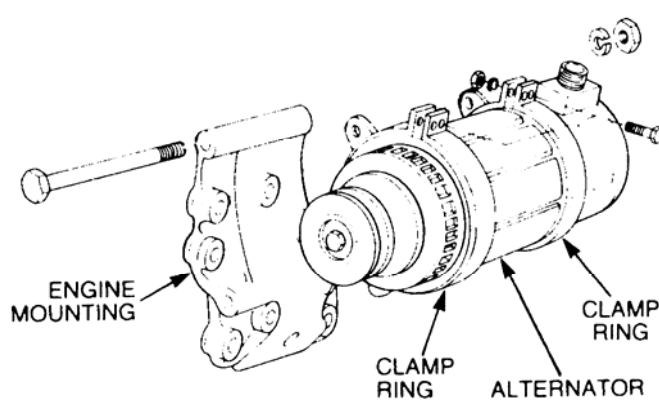

Figure 3 Alternator Installation

WARNING

The 28 volt alternator is heavy. Care must be taken on installation or personal injury may result.

- b. Support the 28 volt alternator and clamp rings beside the engine mounting.
- c. Insert the two bolts that secure 28 volt alternator to the engine mounting,
- d. Install the nuts and new lock washers and tighten securely.

NOTE

Ensure that the 28 volt alternator and crankshaft pulleys are aligned by using a suitable straight edge.

- e. Connect the cannon plug.
- f. Using new lockwashers, install the four bolts and nuts on the clamp rings.
- g. Tighten the nuts securely.
- h. Fit the two fanbelts in the pulley grooves.
- i. Position the pulley arm to allow a deflection of 5 – 10 mm on the longest span of the belts.
- j. Tighten the adjusting bolt securely.
- k. Lock wire the cannon plug to the 28 volt alternator.
- l. Connect the vehicle and FFR system batteries.

Wiring Harness

20. **General Precautions.** Exercise the following precautions when working on the wiring harness:

CAUTION

Arcing wires to earth to determine if the wire is live will destroy solid state components.

- a. Use suitable testing meters or circuit testers to trace or locate faults and check circuits.
- b. After tracing electrical faults and before carrying out any electrical repairs, disconnect the batteries, negative terminals first.

CAUTION

Failure to disconnect the alternators will cause the transistors and diodes to fail as a result of current flow throughout the chassis when arc welding.

- c. Before carrying out any electrical arc welding on the vehicle disconnect the batteries and both alternators.

CAUTION

Reversing battery polarity will cause serious damage.

- d. When installing the batteries, ensure that the terminals are connected to the correct posts.
- e. The layout of the rear wiring harness for vehicle fitted for radio is shown in Figure 4.

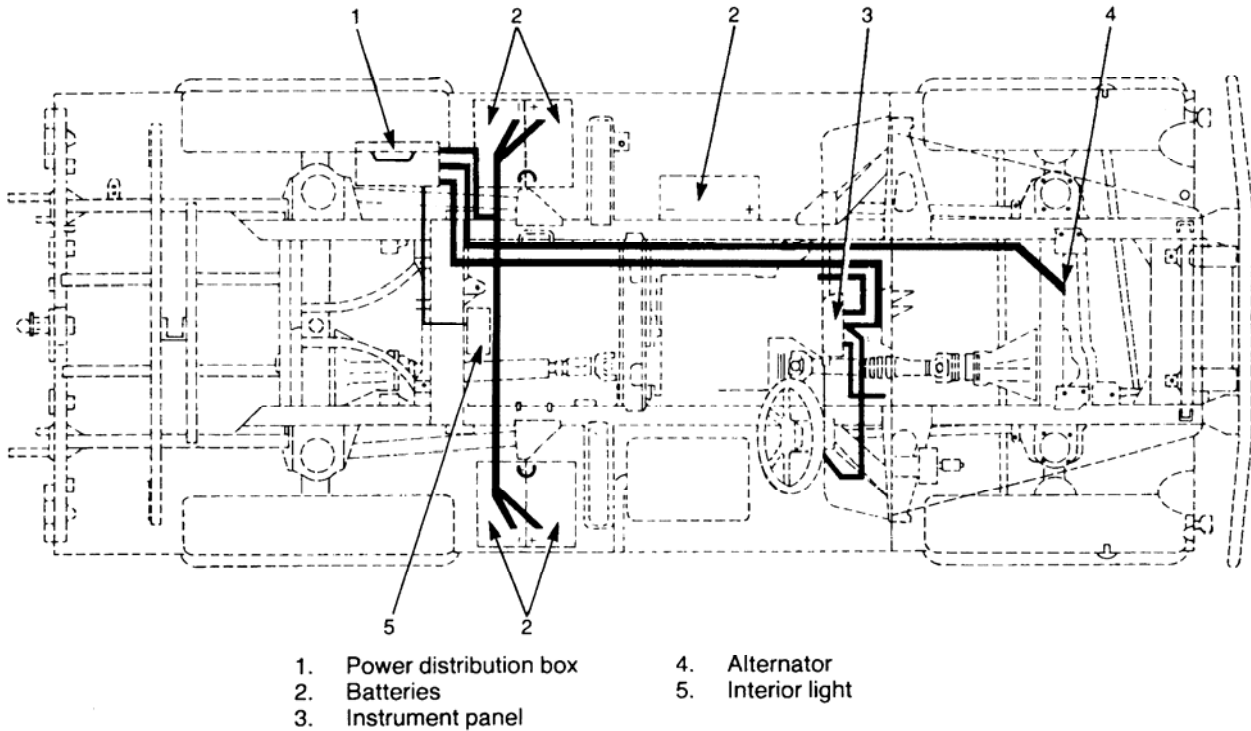

Figure 4 Rear Wiring Harness (FFR)

21. **Replacement.** Replace the wiring harness as follows:

- a. Disconnect the batteries, negative terminals first, (refer Figure 5).

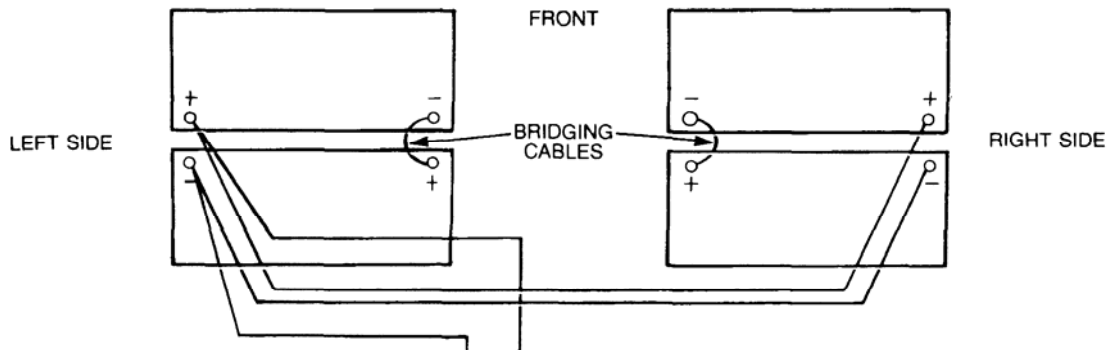

Figure 5 Batteries Installation

NOTE

All electrical wiring in the vehicle is colour coded for identification and reference. If necessary, refer to the wiring diagram in EMEI Vehicle G 103, in conjunction with the relevant illustration, when replacing a wiring harness.

- b. Determine which harness is to be replaced and ensure that the replacement harness is of the correct capacity and that the wires are correctly colour coded.
- c. Using the old harness and tags as a guide, connect the wires to the appropriate terminals.
- d. Test the function of the components associated with the wiring harness that has been replaced to ensure correct function.

UNCONTROLLED IF PRINTED

Interior Lamps

NOTE

The interior lamps are located in the vehicle roof in the rear of the vehicle. There are two lens assemblies, one white and one red. Before proceeding determine which assembly is faulty. The interior lamp switch is a single pole double throw switch. The centre position of the switch is the OFF position; the ON positions will switch either the red or white light assembly.

22. **Bulb Replacement.** Replace the bulb in the interior lamp as follows:

- a. Remove the two screws securing the lens (refer Figure 6).

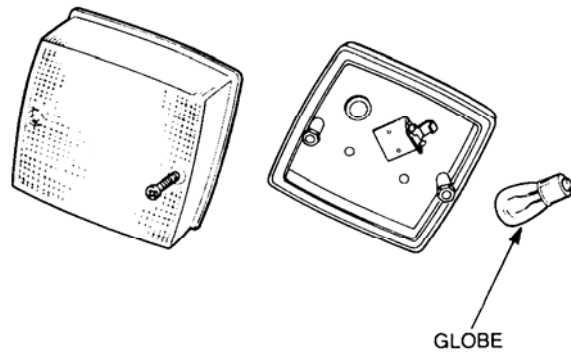

Figure 6 Interior Lamps Exploded View

- b. Remove the lens.
- c. Remove the bulb.
- d. Install a new bulb.



Do not over tighten the lens screws as the lens may crack.

- e. Replace the lens.

23. **Lamp Unit Replacement.** Replace the lamp unit as follows:

- a. Remove the two screws securing the lens.
- b. Remove the lens.
- c. Tag and disconnect the lamp harness from the lamp switch.
- d. Remove the two nuts and washers securing the lamp unit to the mounting panel.
- e. Remove and discard the lamp unit.
- f. Position the new lamp unit on the mounting panel.
- g. Secure with the two nuts and washers.
- h. Install the lens.
- i. Secure with the two lens screws.
- j. Connect the lamp harness to the lamp switch.

Interior Lamps Switch

24. **Replacement.** Replace the interior lamps switch as follows:

- a. Disconnect the batteries.

- b. Tag and disconnect the lamp and wiring harnesses from the lamp switch.
- c. Remove the nut securing the switch to the mounting panel.
- d. Remove and discard the switch.
- e. Position the new lamp switch on the mounting panel.
- f. Secure with the nut.
- g. Connect the wiring harnesses to the lamp switch.
- h. Connect the batteries.

Batteries (28 Volt Installation)

25. **Replacement.** Replace the batteries (28 volt installation) as follows:
- a. Switch off the master switch on the power distribution box.
 - b. Remove the security clip and pin from the left hand battery carrier (refer Figure 7).

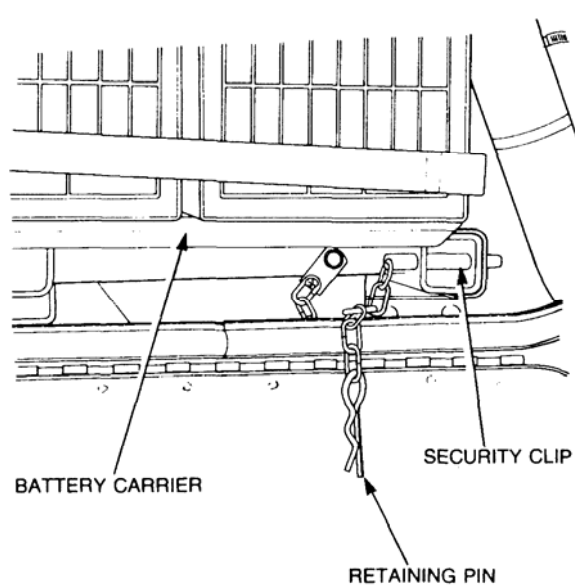

Figure 7 Left Side Battery Compartment

- c. Slide the batteries and carrier clear of the vehicle body until the small bridging cable is exposed.
- d. Disconnect the bridging cable from both the positive and negative terminals on the batteries.
- e. Remove the bridging cable.
- f. Repeat the procedure, detailed in sub paragraphs b to e, for the batteries installed on the right side of the vehicle.
- g. Disconnect the remaining cables from the batteries.
- h. Remove the nuts and washers securing the battery retaining bracket.
- i. Remove the battery retaining bracket.
- j. Lift the batteries out of the battery carrier.
- k. Install the batteries in the battery carrier.

NOTE

Ensure that the batteries are installed correctly (refer Figure 5).

- l. Secure the batteries with the retaining bracket.
- m. Connect the battery cables and stow the battery carriers.

- n. Secure the battery carriers with the security clip and pin.
- o. Switch on the master switch on the power distribution box.

Electrical System (28 Volt) Fault Finding

26. The procedures for electrical system (28 Volt) fault finding are detailed in Table 4.

Table 4 Electrical System (28 Volt) Fault Finding

Serial	Symptom	Probable Cause	Action
1	Low reading on ammeter.	Loose fan belt.	Tighten to correct tension.
		Defective regulator.	Test / replace end bell assembly.
		Poor connection in charging circuit.	Rectify.
		Defective batteries.	Replace defective batteries.
		Defective rectifier.	Test / replace end bell assembly.
2	No reading on ammeter.	Open circuit regulator sensing line.	Test / rectify defective sensing line switch or relay.
		Defective fan belt.	Replace fan belt.
		Loose or disconnected Cannon plug.	Tighten plug.
		Open circuit in main circuit.	Test / rectify defect.
		Defective regulator.	Test / replace end bell assembly.
		Open circuit in RF filter capacitor(s).	Test / replace end bell assembly.
		Disconnected field leads.	Refit / tighten plugs.
		Open circuit batteries.	Test / replace batteries.
		Defective relay.	Test / replace relay.
3	Alternator overheating.	Defective connection resulting in arcing.	Tighten connections.
		Restricted or blocked air grille.	Clean air grille.
		Alternator delivering maximum continuous output.	Check regulator sensing line for high resistance or poor connection.
		Defective regulator.	Test / replace end bell assembly.
		Rectifier diode(s) defective.	Test / replace end bell assembly.
		Defective batteries.	Test / replace batteries.
4	Alternator noisy.	Defective bearings.	Replace alternator.
		Loose fan or pulley.	Rectify.
		Loose alternator mountings.	Rectify.
		Defective rectifier.	Test / replace end bell assembly.
5	Intermittent overcharging.	High resistance or poor connection in regulator sensing line.	Rectify.
		Defective regulator.	Test / replace end bell assembly.
		Loose battery terminals.	Rectify.
6	No reading on battery condition indicator when master switch is in the ON position.	Defective indicator.	Replace indicator.
		Open circuit in the power distribution box wiring harness.	Rectify.
		Defective fuse.	Replace fuse.
		Defective circuit breaker in the power distribution box.	Replace circuit breaker.
		Loose battery terminals.	Rectify.

UNCONTROLLED IF PRINTED

Table 4 Electrical System (28 volt) Fault Finding (Continued)

Serial	Symptom	Probable Cause	Action
7	Low reading on battery condition indicator when master switch is in the ON position.	Defective batteries.	Test / replace batteries.
		Defective indicator.	Replace indicator.
8	Hour meter not working.	Defective hour meter.	Replace hour meter.
		Open circuit in hour meter wiring.	Rectify.

Hour Meter or Amp Gauge Replacement

27. Removal. Remove the faulty gauge as follows:

- a. Disconnect the batteries.
- b. Remove the four screws securing the instrument panel to the trim panel (refer Figure 8).

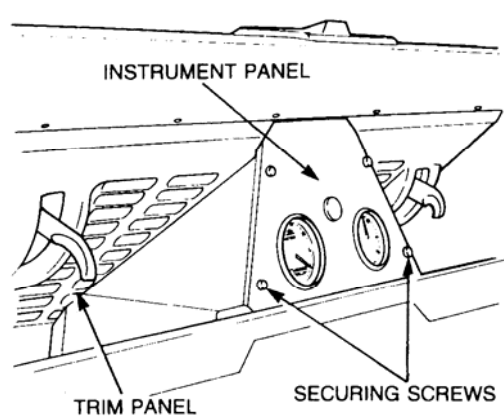

Figure 8 Instrument Panel Removal

- c. Ease the instrument panel away to allow access to the wiring harness.
- d. Tag and disconnect the wiring harness from the gauge to be removed.
- e. Remove the two nuts and clamp plate securing the gauge to the panel.
- f. Remove the faulty gauge.

28. Installation. Install the replacement gauge as follows:

- a. Fit the gauge into the instrument panel.
- b. Secure the gauge with the two nuts and clamp plate.
- c. Connect the wiring harness to the gauge.

NOTE

Ensure that the connectors are fitted to the correct terminals.

- d. Fit the instrument panel to the trim panel.
- e. Secure the instrument panel with the four screws.
- f. Connect the batteries.

Forced Air Ventilator

29. Removal. Remove the forced air ventilator as follows:

- a. Switch off the master switch on the power distribution box.

UNCONTROLLED IF PRINTED

- b. Disconnect the vehicle batteries.
- c. Remove the six screws securing the fascia panel to the ventilation ducting (refer Figure 9).
- d. Withdraw the fascia panel until the electrical harness connections are accessible.
- e. Tag and disconnect the harness.
- f. Remove the fascia panel and fan assembly from the vehicle.

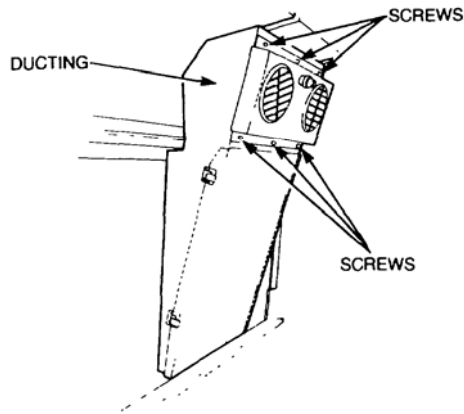

Figure 9 Forced Air Ventilator Removal

- g. Tag and disconnect the wires from the control switch and fan motor (refer Figure 10).

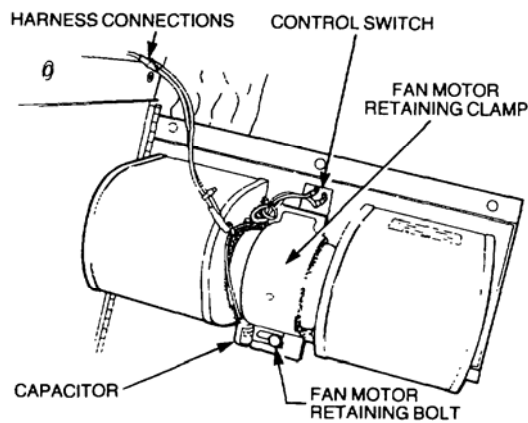

Figure 10 Fan Motor Removal

- h. Remove the bolt securing the retaining clamp and capacitor.
 - i. Remove the retaining clamp.
 - j. Lift the motor and impellers out of the mounting base.
30. **Installation.** Install the forced air ventilator as follows:
- a. Place the motor and impellers in the mounting base.
 - b. Connect the wires to the correct terminals on the control switch.
 - c. Install the retaining clamp and capacitor.
 - d. Secure the retaining clamp with the bolt.
 - e. Tighten the bolt securely.
 - f. Position the fascia panel and fan assembly on the ducting.
 - g. Connect the electrical harness.
 - h. Insert the fascia panel and fan assembly into the ducting aperture.

UNCONTROLLED IF PRINTED

- i. Secure the panel with the six screws.
- j. Tighten the screws securely.
- k. Connect the vehicle batteries.
- l. Switch on the master switch fitted to the power distribution box.
- m. Operate the fan control switch, checking that all three speeds are operational.

Fan Control Switch

31. Replacement. Replace the fan control switch as follows:

- a. Switch off the master switch on the power distribution box.
- b. Disconnect the vehicle batteries.
- c. Remove the six screws securing the fascia panel to the ventilation ducting (refer Figure 9).
- d. Withdraw the fascia panel until the electrical harness connections are accessible.
- e. Tag and disconnect the harness.
- f. Remove the fascia panel and fan assembly from the vehicle.
- g. Tag and disconnect the wires from the control switch.
- h. Remove the control knob.
- i. Remove the nut and washer securing the switch to the fascia panel.
- j. Remove the switch.
- k. Insert the new switch into the fascia panel.
- l. Secure the new switch with the lock washer and large nut.
- m. Install the control knob.
- n. Connect the wires to the control switch.
- o. Position the fascia panel and fan assembly on the ducting.
- p. Connect the electrical harness.
- q. Insert the fascia panel and fan assembly into the ducting aperture.
- r. Secure the panel with the six screws.
- s. Tighten the screws securely.
- t. Connect the vehicle batteries.
- u. Switch on the master switch fitted to the power distribution box.
- v. Operate the fan control switch, checking that all three speeds are operational.

Air Filter

32. Removal. Remove the air filter as follows:

- a. Release the two spring catches (refer Figure 11).

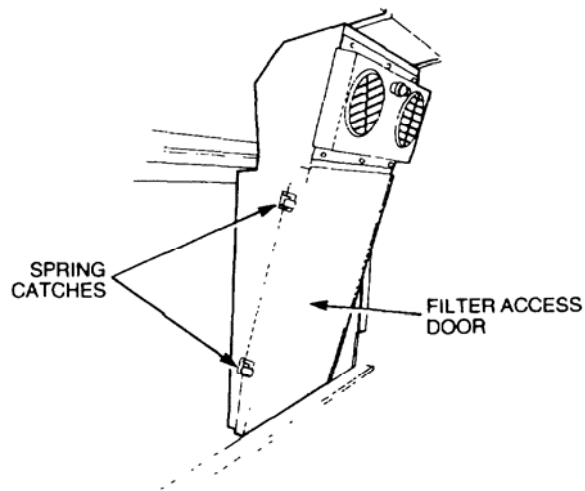

Figure 11 Ducting Door Opening

- b. Open the ventilator ducting filter access door.
- c. Pull the bottom of the filter until the plastic surround clears the lower edge of the door frame (refer Figure 12).
- d. Using a downward movement remove the filter assembly.

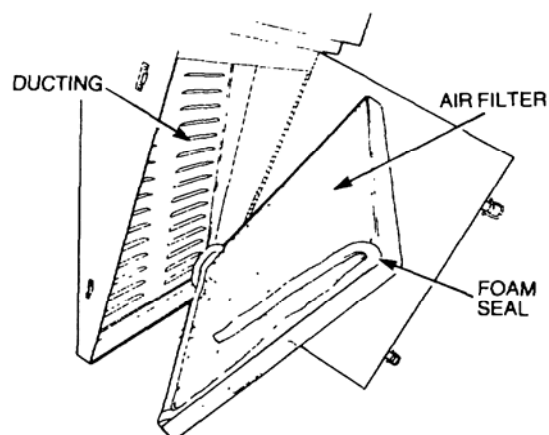

Figure 12 Air Filter Removal

33. **Cleaning and Inspection.** Clean and inspect the air filter as follows:
 - a. Shake off any loose dirt.
 - b. Rinse in clean cold water and liquid detergent.
 - c. Rinse thoroughly in clean water.
 - d. Shake off and allow to dry thoroughly.
 - e. Inspect the filter assembly for any cracks in the frame or damaged screen and replace as necessary.
34. **Installation.** Install the air filter as follows:
 - a. Insert the top edge of the filter frame into the channel of the ducting.
 - b. Push the lower edge of the filter frame into the ventilation duct.
 - c. Secure the filter frame in position by closing the access door.
 - d. Secure the door with the two spring catches.

BODY – GROUP 17

Rear Door

35. **Removal.** Remove the rear door as follows:
- Remove the split pin securing the door check link clevis pin to the bracket.
 - Remove the washer and pin.
 - Disconnect the number plate lamp wiring at the connectors.
 - Support the door and remove the three screws, tabs washers and nuts securing the hinge valves together (refer Figure 13).
 - Lift the door off the hinge halves.
 - Remove the brass inserts.

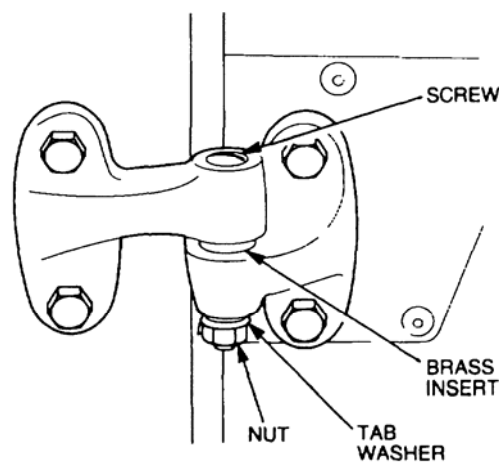

Figure 13 Rear Door Removal

36. **Installation.** Install the rear door as follows:
- Position the three brass inserts on the hinges.
 - Fit the door.
 - Install the three screws, tab washers and nuts (refer Figure 13).
 - Tighten the nuts sufficiently to remove all slack.
 - Secure with the lock tab.

Rear Door Glass

37. **Removal.** Remove the rear door glass as follows:
- Open the rear door.
 - Remove the nine screws securing the lower glass retainer to the door frame.
 - Remove the retainer (refer Figure 14).

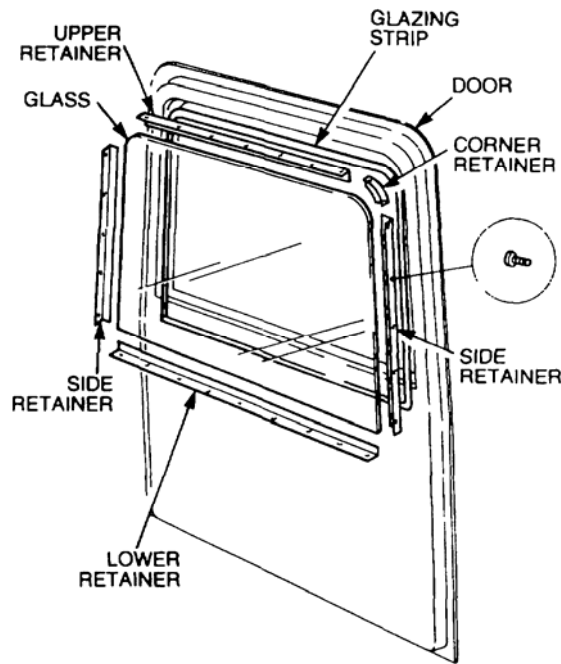

Figure 14 Rear Door Glass Removal

- UNCONTROLLED IF PRINTED
- d. Remove the five screws securing each of the two side glass retainers to the door.
 - e. Remove the two side glass retainers.
 - f. Remove the two screws securing each of the upper corner retainers to the door.
 - g. Remove the upper corner retainers.
 - h. Remove the seven screws securing the upper glass retainers to the door.
 - i. Remove the upper glass retainers.
 - j. Remove the glazing strip from around the inside of the window.
 - k. Carefully push the glass inwards from the window aperture.
 - l. Remove all traces of sealant used around the glass retainers and door.
- 38. Installation.** Install the rear door glass as follows:
- a. Apply a thin bead of sealant around the window aperture.
 - b. Fit the glass.
 - c. Install a new glazing strip, (refer Figure 14), on the inside of the window.
 - d. Fit all the retainers.
 - e. Tighten all the retaining screws securely.
 - f. Trim off any excess sealant.

END

Distribution List: **VEH G 16.5 – Code 2** (Maint Level)
(Sponsor: LV SPO, Light B Vehicles)
(Authority: TRAMM)