

TRUCK, UTILITY, L/W, MC2, FFR, LAND ROVER 110

PREPARATION OF RIGHT HAND BRACKET AND BUMPER ASSEMBLY, JERRICAN HOLDER, FOR FITTING OF MAST ANTENNA GENERAL PURPOSE AB-F300

MODIFICATION INSTRUCTION

This instruction is authorised for use by command of the Chief of Army. It provides direction, mandatory controls and procedures for the operation, maintenance and support of equipment. Personnel are to carry out any action required by this instruction in accordance with EMEI General A 001.

INTRODUCTION

1. This instruction details the modification of the jerrican holder to facilitate attaching the Mast Antenna, General Purpose AB-F300 Lower Bracket of the Land Rover FFR Mounting Kit. This requirement is for the Land Rover 110 FFR and Land Rover 110 FFR with winch.
2. **Associated Publications.** Reference may be necessary to the latest issue of the following documents:
 - a. [UHB pdf](#) Operating and Maintenance Handbook - Mast Antenna General Purpose AB-F300, NIIN:66-130-4101;
 - b. [EMEI/Tels/t637-1.pdf](#) EMEI Tels T 637-1;
 - c. <http://vbmweb.sor.defence.gov.au/TECHDATA/dofa/RPS/02188-01-03> Repair Parts Scale-02188-Truck, Utility, L/W, MC2, Land Rover 110;
 - d. [TRAMM-L pdf](#) Technical Regulation of Army Materiel Manual-Land (TRAMM-L); and
 - e. [ESCM](#) Electronic Supply Chain Manual (ESCM).
3. **Authority.** DAAR CGSVSPO with BCOG References, ECO: 2000/0001 dated 15 July 2010 and minute AGDA 2003/36641 dated 11 June 2010.

GENERAL

4. **Modification Application.** This modification is to be applied to all subject vehicles on issue or in service storage.
5. **Items Affected.** This modification alters the jerrican holder right hand.
6. **Priority – Group 2.** All applicable equipment is to be modified:
 - a. when next in a workshop for Light, Medium or Heavy Repair; or
 - b. prior to issue from depot or pool stock.

NOTE

Where modification would delay priority issues of depot or pool stock, equipment may be issued unmodified providing the equipment record book is endorsed appropriately.

7. **Actions Required.** Actions detailed in this instruction are to be performed by technical maintenance organisations authorised to carry out Light, Medium or Heavy Grade Repairs.

NOTE

On receipt of this instruction, enter all relevant information other than date completed in the modifications section of the GM 120 – Record Book for Service Equipment.

8. **Estimated Work Hours.** For initial planning purposes only, it is estimated that this modification will take 0.5 work hours to perform.

DETAIL

NOTE

Ensure jerrican is removed from the jerrican holder right hand prior to drilling.

9. **Modification of Jerrican Holder Right Hand.** The procedure is as follows:
- mark and centre punch the four (4) holes (to be drilled), as detailed in Figure 1;
 - drill four (4) holes using 11 mm drill bit; and
 - de-burr the holes.

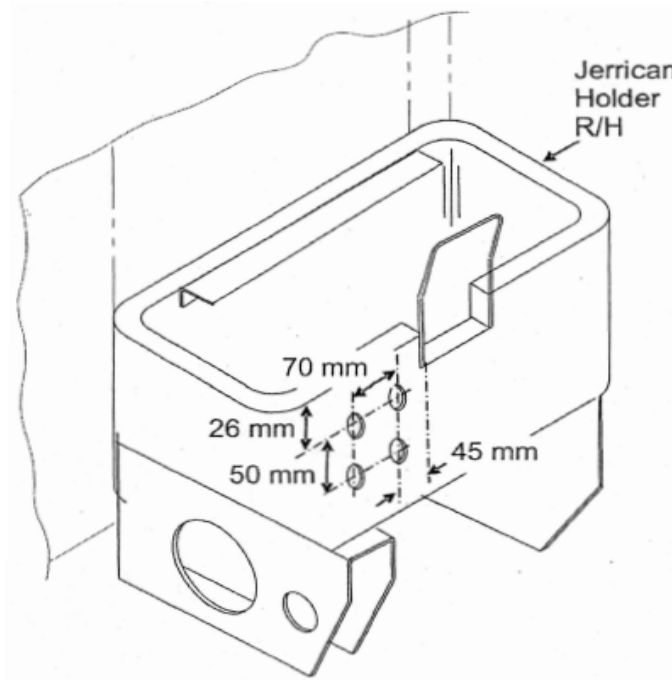

Figure 1 Position of Holes

10. **Recording Action.** On completion of the modification, the following action is to be taken in accordance with the TRAMM-L:

- Deface the number 35 on the Land Rover (both FFR and FFR w/winch) modification record plate;
- Complete the modification details in the GM 120 – Record Book for Service Equipment; and
- Forward the modification completion details using form GM 119 – Advice of Change in Build State to:

National Fleet Manager Lt B Vehicles
CGSVSPO, DMO
Defence Plaza, 661 Bourke St
MELBOURNE VIC 3000

END

Distribution List: **VEH G 16.1 – Code 1** (Maint Code)
(Sponsor: CGSVSPO, LT B)
(ECO CNR 2000/0001)