

TRUCK, UTILITY, LIGHTWEIGHT, MC2 - LAND ROVER 110 4X4 CARGO

FITTING OF STRETCHER RETAINING CLAMPS

MODIFICATION INSTRUCTION

This instruction is authorised for use by command of the Chief of the General Staff. It provides direction, mandatory controls and procedures for the operation, maintenance and support of equipment. Personnel are to carry out any action required by this instruction in accordance with GENERAL A 001.

Introduction

1. This instruction details the fitting of stretcher retaining clamps to the rear of Land Rover 110 4x4 Cargo variants to allow the fitting of two stretchers for the carriage of casualties. The front seats are also to be repositioned approximately 20 mm inboard, on early vehicles, to prevent the stretcher handles fouling the seats.

NOTE

DSN, NSN, MPN and Designations used in this instruction were correct at the time of issue. If 12 months or more have passed since issue the DSN, NSN or MPN should be checked for supersession.

2. *Associated Publications.* The latest issue of the following references should be read in conjunction with this instruction:

- a. EMEI Workshop A 850 - Modifications, Trial Modifications and Local Modifications to Equipment;
- b. EMEI Workshop A 851 - Modifications to Equipment - Use of Modification Record Plates and Documentary Requirements; and
- c. HQ Log Comd Equipment Maintenance Program (EMP) 3/91.

3. *Authority.*

- a. Project Perentie TVA TU9127, and
- b. Land Rover Engineering Change 2096.

General

4. *Modification Application.* All Land Rover 110 4x4 Cargo variants.

5. *Items Affected.* Front seats and rear cargo body.

6. *Priority - Group 2.* All applicable equipment is to be modified:

- a. when next in workshops for repair, or

- b. prior to issue from depot or pool stock.

NOTE

Where modification would delay priority issues of depot or pool stock, equipment may be issued unmodified providing the Record Book for Service Equipment (GM 120) is endorsed with details of the outstanding modification.

7. *Action Required.* Actions detailed in this instruction are to be performed by RAEME units or sub units authorised to carry out unit, field or base repairs.

8. *Estimated Manhours to Perform.* For initial planning purposes only, it is estimated that this modification will take 1.5 man-hours to perform.

9. *Special Equipment.* Round pole stretcher, to be used as a template during fitting.

10. *Stores Required.* The stores required are listed in Table 1 and are to be demanded through Moorebank Log Gp. Parts kits are provided by Rover Australia to Army and are not to be procured locally. Kits are supplied on the basis of one kit per vehicle and are not to be ordered for stock. The rivets shown in Table 2 are for identification purposes and an equivalent item may be used. The rivets are to be ordered through normal supply channels.

Fitting of Stretcher Retaining Clamps

11. Proceed as follows:

- a. Mark the centre line of the vehicle and the holes for the clamp mounting bolts on the front and rear bulkheads, as shown in Figure 1.

NOTE

Do not use the Steyr barrel clip bracket as a reference when measuring the center line.

The Steyr mounting clips and butt box must be fitted, as detailed in Log Comd EMP 3/91, to allow the stretcher retaining clamps to be fitted to the front bulkhead.

Table 1 - Stores Required (to be demanded through Moorebank Log Gp)

Item	DSN	Mfr Part No	Description	Qty per Equip
1	2540-97-121-3066	HYG6428	Kit, Stretcher Clamps comprising items 1 to 5 in Table 3	1

Table 2 - Stores Required (to be demanded through normal supply channels)

Item	NSN	Mfr Part No	Description	Qty per Equip
1	-	RU608313	Rivet, Aluminium, Pop, 3.2 mm diameter, 10 mm lg	8

- b. Drill 7.0 mm holes for the clamp mounting bolts in the front and rear bulkheads, as shown in Figure 1.
- c. Remove or file flat the two outboard pop rivets fixing the Steyr barrel clip mounting bracket to the front bulkhead.
- d. Fit the clamps (item 1 from Table 3), using screws, nuts and washers (items 2, 3 and 4 from Table 3), so that the step in the clamp base mates with the step in the body metal.

NOTE

The stretcher clamps are fitted to the front bulkhead with the hinge pins toward the center of the vehicle and on the rear bulkheads with the hinge pins toward the outside of the vehicle.

- e. Fit a round pole stretcher to each pair of retaining clamps to ensure that there is clearance between the Steyr barrel clip bracket and the poles.
- f. Round the corners of the Steyr barrel clip bracket and remove any burrs to prevent

injury to personnel during subsequent fitting of stretchers.

Seat Relocation

- 12. Proceed as follows:

NOTE

The front seats were repositioned in production, as detailed in the following paragraphs, in late 1990. Fit a round pole stretcher and check that the rail is not putting undue force on the outboard side of each seat back. The repositioned outboard seat mounting holes are approximately 70 mm from the outside edge of the seat base on the passenger side and 90 mm on the driver's side.

- a. Remove the front seats from the vehicle.
- b. Remove the battery box cover, fuel sender access panel and Steyr butt box from the seat box.
- c. Remove the pop rivets holding the seat base nut retention plates under the seat base (retain the plates).

Table 3 - Components Contained in Modification Kit (to assist parts identification and not to be indented for to complete the modification)

Item	NSN	Mfr Part No	Description	Unit of Issue	Qty per Kit
1	-	HYG6280	Clamp, Stretcher Retaining	ea	4
2	5305-99-135-0442	SE106251	Screw, Metric Coarse, 6 mm diameter, 25 mm lg	ea	8
3	5310-99-122-6474	WA106041	Washer, Flat, 6 mm ID	ea	8
4	5310-99-139-5313	NY106041	Nut, Nyloc, Metric Coarse, 6 mm	ea	8
5	-	DOI-Y-838	Drawing	ea	1

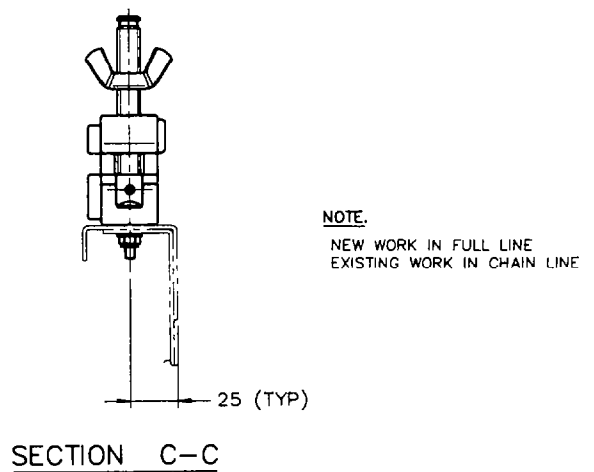
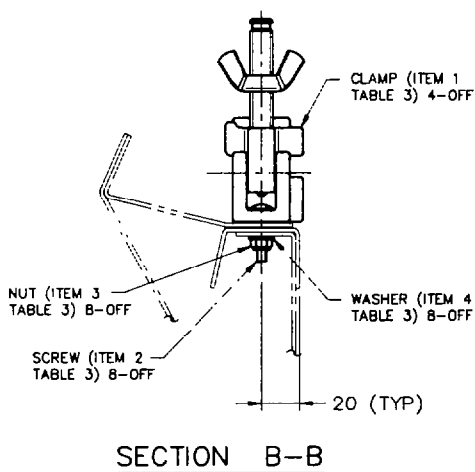
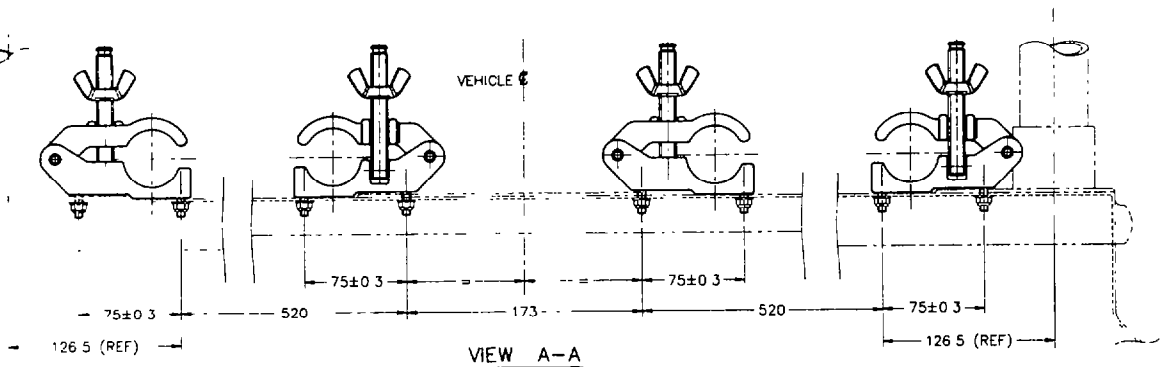
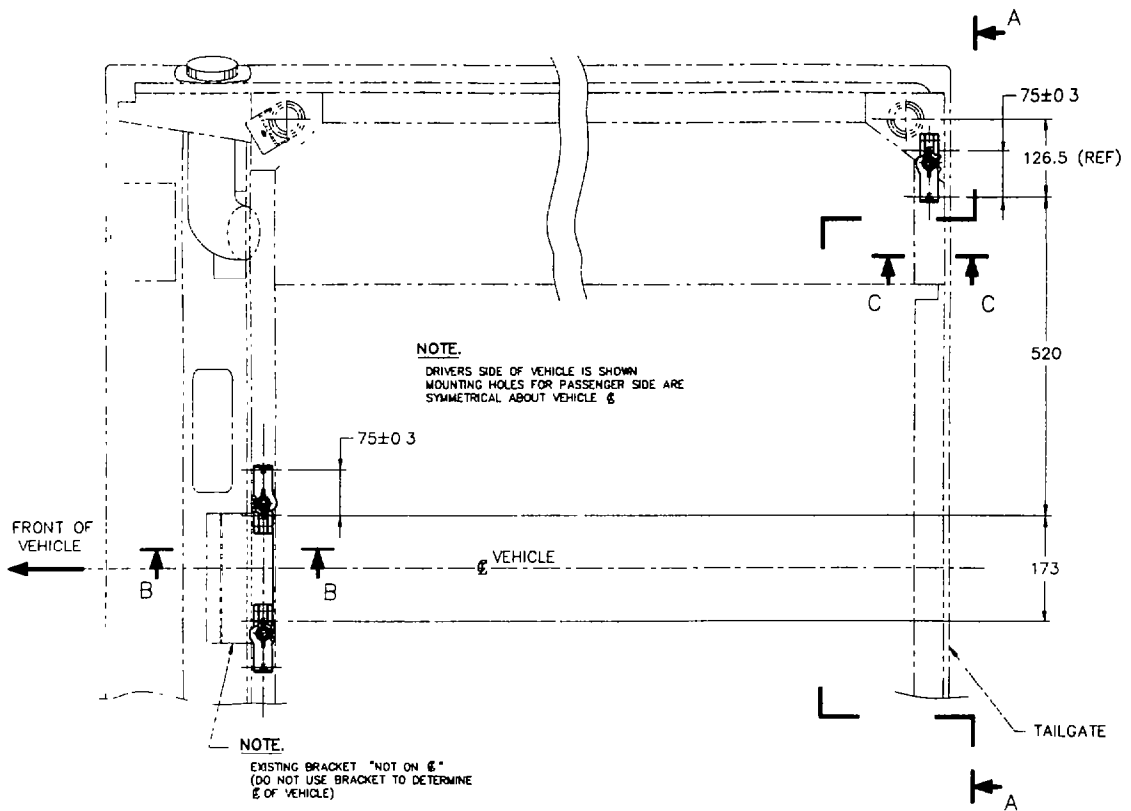

Figure 1 - Stretcher Clamp Mounting

d. Mark and drill holes shown in Figure 2, as follows:

- (1) seat mounting bolt holes, 10 mm diameter hole, 20 mm inboard from the original holes, and
- (2) seat nut retention plate holes, 3.3 mm diameter hole, 16 mm inboard from the original holes.

e. Refit the seat base nut retention plates with new pop rivets, item 1 from Table 2.

f. Cover the old seat mounting holes with fabric tape or suitable sealant.

g. Refit the battery box cover, fuel sender access panel and Steyr butt box to the seat box.

h. Refit the front seats to the vehicle.

13. *Post Modification Testing.* Fit a round pole stretcher to the retaining clamps on each side of the vehicle to confirm installation.

14. *Recording Action.* On completion of the modification:

a. deface the number 23 on the modification plate located on the driver's seat base, and

b. enter the details of the modification in Part 3 of the GM 120, Record Book for Service Equipment, for the subject vehicles.

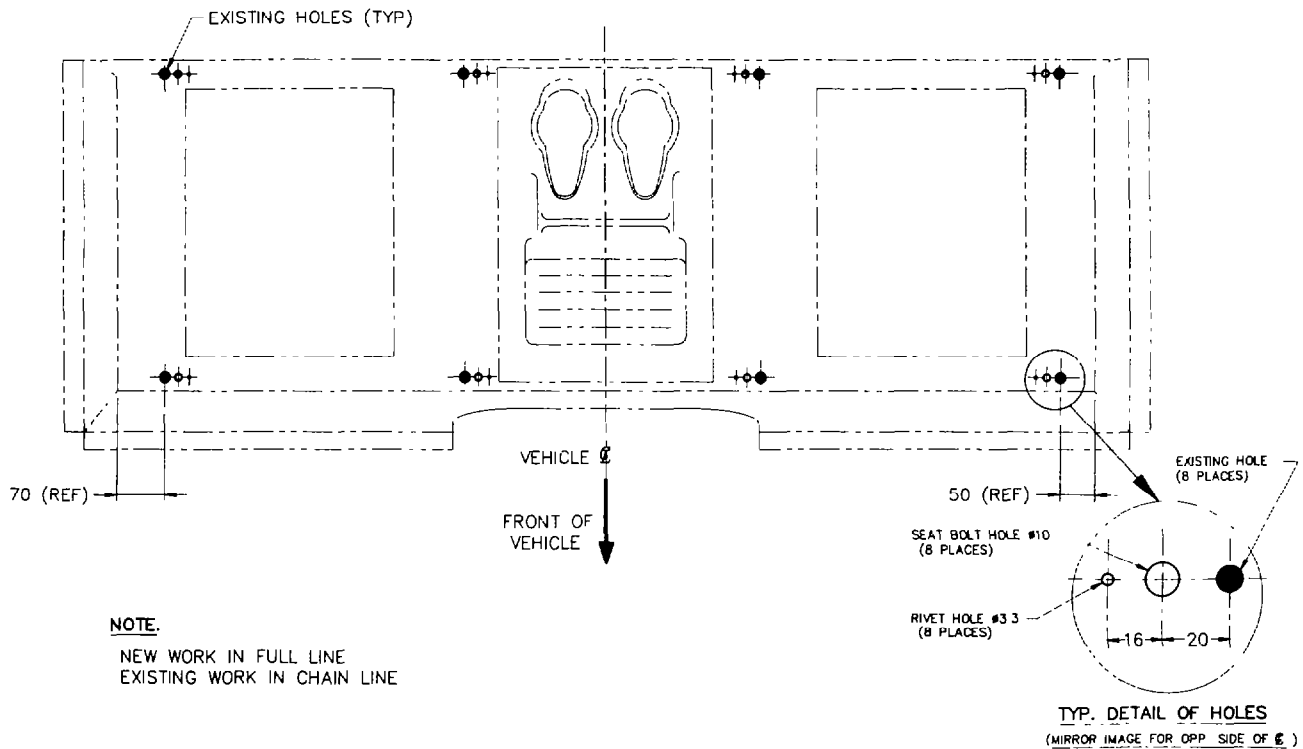

Figure 2 - Seat Base Mounting Holes

END

List VEH G 16.2 - Code 4 (MEA 910176)