

**TRUCK, CARRYALL, LIGHTWEIGHT, PERSONNEL CARRIER, MC2 –  
LAND ROVER 110**

**MEDIUM AND HEAVY GRADE REPAIR**

This instruction is authorised for use by command of the Chief of Army. It provides direction, mandatory controls and procedures for the operation, maintenance and support of equipment. Personnel are to carry out any action required by this instruction in accordance with EMEI General A 001.

**TABLE OF CONTENTS**

	<b>Page No</b>		<b>Page No</b>
Introduction .....	3	Windscreen Glass.....	5
Associated Publications .....	3	Heavy Grade Repair .....	6
General .....	4	Body – Group 17 .....	6
Location of Identification Numbers.....	4	Body.....	6
Medium Grade Repair.....	5	Tropical Roof .....	13
Body – Group 17.....	5		

**LIST OF FIGURES**

	<b>Page No</b>		<b>Page No</b>
Figure 1 Rubber Seal – Installing Rope .....	5	Figure 9 Removal of the Windscreen Frame Cover .....	9
Figure 2 Rubber Seal – Applying Soap Solution.....	6	Figure 10 Removal of the Windscreen Frame Clamp.....	9
Figure 3 Windscreen Frame – Applying Sealant.....	6	Figure 11 Rear Body Mountings .....	10
Figure 4 Installation of the Windscreen Glass.....	6	Figure 12 Removal of the Body Brace Support .....	10
Figure 5 Removal of the Rear Mats .....	7	Figure 13 Removal of the Body Restraining Strap .....	10
Figure 6 Removal of the Sill .....	7	Figure 14 Removal of the Front Body Mounting .....	11
Figure 7 Removal of the Windscreen Frame Bolts .....	8	Figure 15 Removal of the Body Mounting Bolts .....	11
Figure 8 Removal of the Rear Body Bolts.....	8	Figure 16 Removal of the Toe-box Bracket .....	11

**LIST OF TABLES**

	<b>Page No</b>		<b>Page No</b>
Table 1 Location of Identification Numbers.....	4	Table 2 List of Lubricants.....	5

UNCONTROLLED IF PRINTED

UNCONTROLLED IF PRINTED

**Blank Page**

## **INTRODUCTION**

1. This EMEI contains procedures for removing, dismantling, repairing, assembling and installing various components of the Truck, Carryall, Lightweight, Personnel Carrier. Where applicable, instructions for the adjustment, lubrication and minor servicing of these items are included. The EMEI is segregated into both Medium and Heavy Grade Repair at the appropriate paragraphs; common information is listed prior to specific repair criteria. This EMEI supersedes EMEI Vehicle G 154-1 Issue 1.



**Do not use adhesive tapes to seal fuel or oil openings. The adhesive tape is soluble in fuel or oil and can cause contamination. Remove temporary covers before assembling.**

2. Prevent dirt and foreign objects from entering any component by placing clean temporary coverings over all exposed openings, including hoses, tubes and lines.



**Before removing any electrical system components, disconnect the battery leads.**

3. When disconnecting electrical connectors, hoses and fittings, remove clamps as required to gain slack and to avoid damage to connectors and fittings.

4. Discard all used gaskets, seals, cotter pins, tab washers, lock pins, key washers and lock washers. Dispose of all contaminated fuel and lubricants drained from the vehicle in accordance with current local instructions.

5. Use only those fuels and lubricants specified in the Servicing Instruction, EMEI Vehicle G 109, the User Handbook and this instruction when replenishing fuel or lubricants.

6. Any fastenings or fittings being tightened to prescribed torques are to have dry, clean threads unless otherwise specified. When specified, thread sealants are to be applied to dry, clean, oil free threads.

7. The engine cooling system contains Nalcool corrosion inhibitor, in water, at a ratio of 1:12.



**Precautions should be taken prior to carrying out repairs which include painting, sanding, scraping or welding. Refer to EMEI Workshop D 701 – Repair Policy for Equipment Painted in Polyurethane Paint.**

8. This vehicle is painted in polyurethane paint.

### **Associated Publications**

9. Reference may be necessary to the latest issue of the following documents:

- a. Defence Road Traffic Instructions;
- b. Complete Equipment Schedules (CES), Truck, Carryall, Lightweight, Personnel Carrier, MC2 – Land Rover 110:
  - (1) SCES 12043; and
  - (2) Equipment Kit SCES 12036;
- c. Block Scale 2406/31 Issue 1 – Special Tools for RAEME- B Vehicles – Truck Utility and Trucks Light MC2 (Land Rover Model 110);
- d. EMEI Vehicle A 029 Vehicles General – Servicing of B Vehicles, Trailers, Motorcycles, Stationary Equipment, Auxiliary and Small Engines;

- e. EMEI Vehicle G 103 Truck, Utility, Lightweight, MC2, Land Rover 110 and Truck, Utility Lightweight, Winch, MC2, Land Rover 110 – Light Grade Repair;
- f. EMEI Vehicle G 104-1 Truck, Utility, Lightweight, MC2, Land Rover 110 and Truck, Utility Lightweight, W/Winch, MC2, Land Rover 110 – Medium Grade Repair;
- g. EMEI Vehicle G 104-2 Truck, Utility, Lightweight, MC2, Land Rover 110 and Truck, Utility Lightweight, W/Winch, MC2, Land Rover 110 – Heavy Grade Repair;
- h. EMEI Vehicle G 109 Truck, Lightweight, MC2, Land Rover 110 4X4 All Types – Servicing Instruction;
- i. EMEI Vehicle G 150 Truck, Carryall, Lightweight, Personnel Carrier, MC2, Land Rover 110 – Data Summary;
- j. EMEI Vehicle G 152 Truck, Carryall, Lightweight, Personnel Carrier, MC2, Land Rover 110 – Technical Description;
- k. EMEI Vehicle G 153 Truck, Carryall, Lightweight, Personnel Carrier, MC2, Land Rover 110 – Light Grade Repair;
- l. EMEI Workshop D 701 Painting of Army Equipment – Repair Policy for Equipment Painted in Polyurethane Paint;
- m. Repair Parts Scale 02195;
- n. Defence Safety Manual ([SAFETYMAN](#)); and
- o. [Material Safety Data Sheets](#) (MSDS)

**WARNING**

**All industrial safety, work practices and equipment operating and maintenance instructions pertaining to this EMEI are to be adhered to.**

**The handling, storage and use of chemical substances are to be in accordance with SAFETYMAN, MSDS and EMEI Workshop series requirements.**

**GENERAL**

**Location of Identification Numbers**

10. The location of identification numbers on components of the vehicle are described in Table 1.

**Table 1 Location of Identification Numbers**

Serial	Identification Number	Location
1	Chassis	Right-hand side of the chassis, forward of the spring mounting turret
2	Chassis nameplate	Left-hand seat box, in the cab
3	Engine	Left-hand side of the engine block
4	Injection pump identification	Side of the pump
5	Transmission and transfer case	Rear of the transfer case
6	Front axle	Adjacent to the axle breather
7	Rear axle	Adjacent to the axle breather

**NOTE**

NSN and Manufacturer's part numbers and designations used in this EMEI were current at the date of issue. If twelve months or more have expired since issue, the NSN and Manufacturer's part number should be checked for supersession.

11. The list of lubricants is detailed in Table 2.

UNCONTROLLED IF PRINTED

**Table 2 List of Lubricants**

Serial	Equipment	Lubricant	Capacity (Litres)
1	Engine (including filter)	OMD-115	8.5
2	Transmission	OMD-115	2.7
3	Transfer case	OMD-115	3.2
4	Front differential	OEP-220	1.7
5	Rear differential	OEP-220	2.3
6	Swivel pin housings	Molytex Grease	EP00 Sachet
7	Brake master cylinder	OX (Aust) 8	Fill to level
8	Clutch master cylinder	OX (Aust) 8	Fill to level
9	Steering box	OEP-220	0.45
10	Wheel bearings	XG-291	As required
11	Radiator inhibitor	Nalcool	As required (1:12 ratio)
12	Clutch pedal trunion	XG-291	As required
13	Speedometer cable	XG-291	As required
14	Propeller shaft	XG-291	As required
15	Parking brake adjuster	XG-291	As required
16	Windscreen wiper drive cable	XG-291	As required

**MEDIUM GRADE REPAIR**

**BODY – GROUP 17**

**Windscreen Glass**

**12. Replacement.** Replace the windscreen glass using the following procedure.

**NOTE**

It will be necessary to utilise a second person to assist in the replacement of the windscreen glass.

- a. Apply even pressure to the inside face of the glass and push the glass and rubber surround out of the frame.
- b. Remove all trace of hardened sealer from the frame.
- c. Install the windscreen rubber on the new glass.
- d. Using approximately four metres of rope with a diameter of seven millimetres, insert the rope into the groove of the rubber seal (Figure 1) starting at the bottom centre of the glass and leaving enough rope at the start to enable the rope to be pulled on installation.

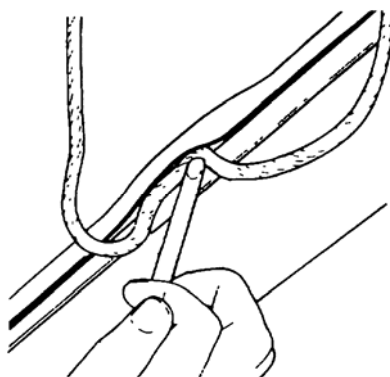

**Figure 1 Rubber Seal – Installing Rope**

- e. Using a solution of soap and water, lubricate the rope and the rubber thoroughly (Figure 2).

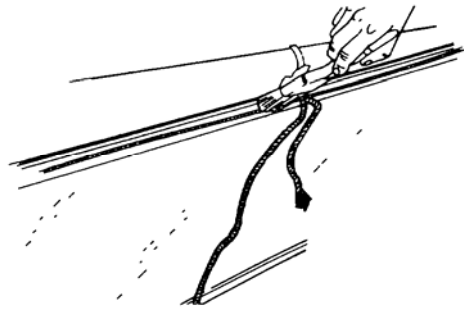

**Figure 2 Rubber Seal – Applying Soap Solution**

- f. Apply a thin bead of suitable sealant to the front face of the windscreen frame flange (Figure 3).

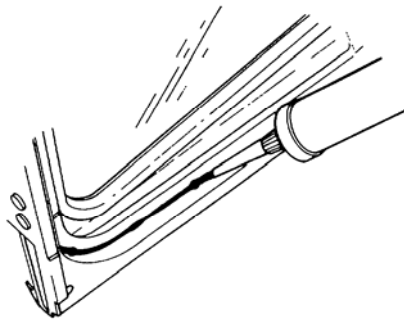
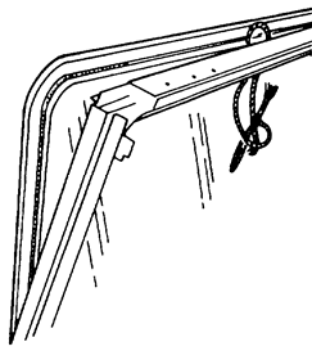

**Figure 3 Windscreen Frame – Applying Sealant**

**NOTE**

The inside face of the glass can be determined by the etched motif.

- g. Position the windscreen glass and rubber in the frame (Figure 4), ensuring that the etched motif on the glass is towards the bottom of the frame.



**Figure 4 Installation of the Windscreen Glass**

- h. Push on the glass continuously and pull one end of the rope around the rubber until the frame flange is correctly located. If the corners are not fitting correctly, remove the glass, install the rope and repeat the actions described in sub-paragraphs g. and h. until the glass is installed.
- i. Press the inside face of the rubber seal to ensure that the glass is seating correctly.

**HEAVY GRADE REPAIR**

**BODY – GROUP 17**

**Body**

- 13. **Removal.** Remove the body as follows:

- a. Remove the battery and cables in accordance with EMEI Vehicle G 103 – Group 15.
- b. Remove the brushguard in accordance with EMEI Vehicle G 103 – Group 16.
- c. Remove the bonnet in accordance with EMEI Vehicle G 104-1 – Group 17.
- d. Remove the mudguards in accordance with EMEI Vehicle G 104-1 – Group 17.
- e. Remove the grille in accordance with EMEI Vehicle G 103 – Group 17.
- f. Remove the radiator in accordance with EMEI Vehicle G 103 – Group 2.
- g. Remove the front doors in accordance with EMEI Vehicle G 153 – Group 17.
- h. Remove the rear doors in accordance with EMEI Vehicle G 153 – Group 17.
- i. Carefully remove the front and rear door seal rubbers from the door frames.
- j. Remove the screw securing the rear mat retaining plates to the floor (Figure 5) and remove the plates and mats.

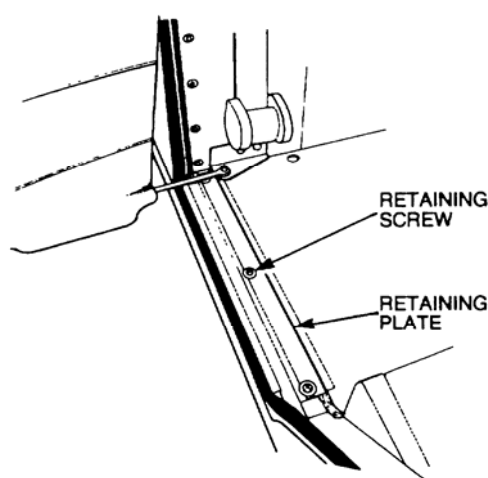

**Figure 5 Removal of the Rear Mats**

- k. Remove the eleven screws securing the rear floor panel to the body and remove the panel.
- l. Remove the front floor panels in accordance with EMEI Vehicle G 103 – Group 17.
- m. Loosen the screws securing the cargo area mat retaining plate, then slide the mat from under the plate and out of the vehicle.
- n. Remove the bolts, nuts and washers securing the sill panel to the body and stay (Figure 6). Repeat the procedure for the opposite side. Remove the plastic clips securing the wheel arch extensions to the sills and remove the sills.

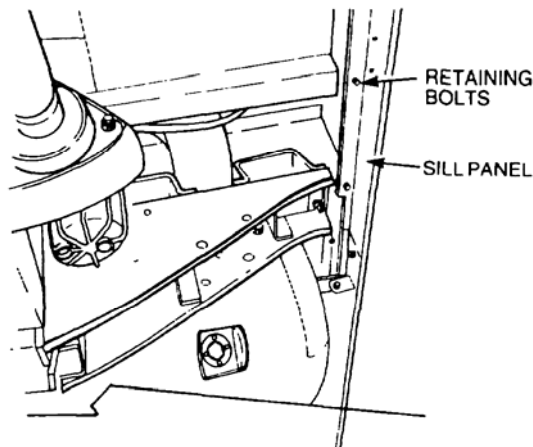

**Figure 6 Removal of the Sill**

- o. Remove the rear and inward facing seats in accordance with EMEI Vehicle G 153 – Group 17.
- p. Remove the eight bolts securing the roof panel to the top of the windscreen frame (Figure 7) and discard the sealing strip.

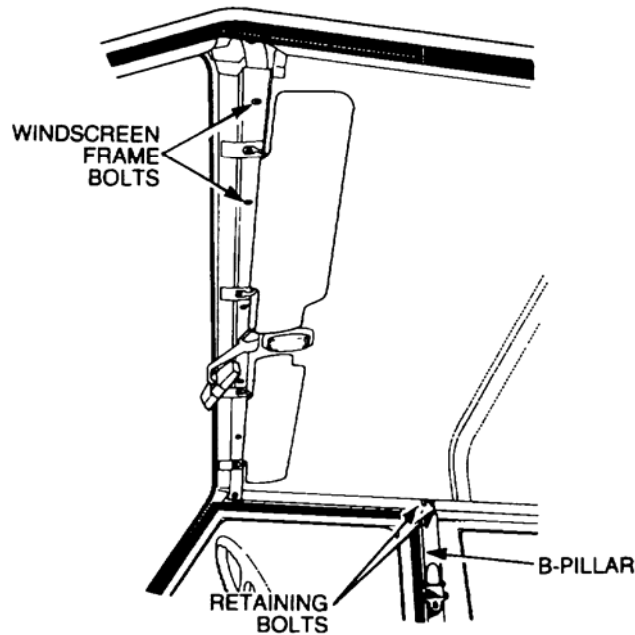

**Figure 7 Removal of the Windscreen Frame Bolts**

- q. Remove the four nuts and bolts that secure the roof panel to the top of pillars B (Figure 7) and C.
- r. Remove the ten nuts and bolts that secure the upper body panels to the lower body frame (Figure 8), then using suitable overhead lifting equipment, with a minimum safe working load of 500 kg, remove the upper body panels from the vehicle. Lower the upper body panels onto suitable axle stands.

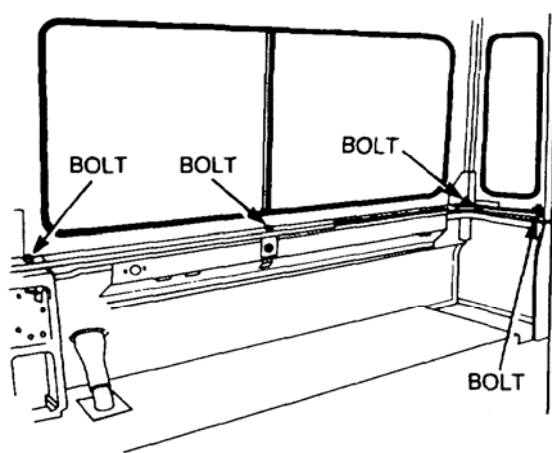
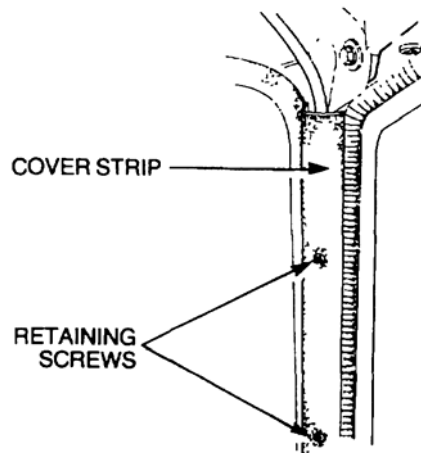

**Figure 8 Removal of the Rear Body Bolts**

- s. Remove both windscreen wiper arms and blades.
- t. Remove the interior light lens then disconnect the wiring harness from the light unit. Remove the harness from the windscreen frame in accordance with EMEI Vehicle G 104-2 – Group 15.
- u. Remove the three screws from each of the vertical cover strips on the inside of the windscreen frame (Figure 9) and remove the cover strip from the vehicle.

UNCONTROLLED IF PRINTED





**Figure 9 Removal of the Windscreen Frame Cover**

- v. Remove the hinge bracket retaining bolts from both sides of the windscreen frame and lift the windscreen assembly away from the vehicle.
- w. Remove the locknuts and washers from the clamps securing the windscreen frame to the firewall (Figure 10).

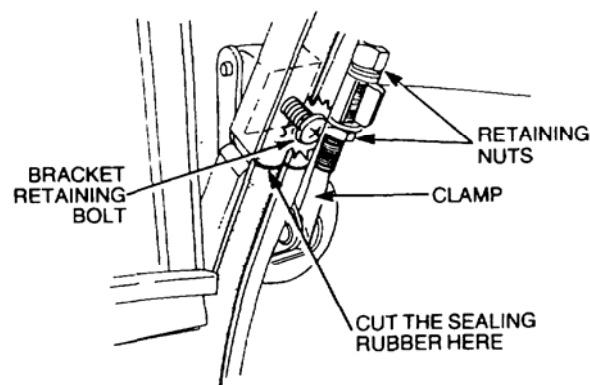

**Figure 10 Removal of the Windscreen Frame Clamp**

- x. Remove the exhaust system in accordance with EMEI Vehicle G 103 – Group 3.
- y. Disconnect the axle and gearbox breather hoses in accordance with EMEI Vehicle G 103 – Group 6.
- z. Remove the speedometer cable in accordance with EMEI Vehicle G 103 – Group 6.
- aa. Tag and disconnect the main wiring harness at the firewall in accordance with EMEI Vehicle G 104-2 – Group 15, then remove all clips and cable ties that secure the harness to the firewall.
- bb. Disconnect the steering column at the firewall in accordance with EMEI Vehicle G104-1 – Group 14.
- cc. Disconnect the fuel tank breather and filler neck hoses in accordance with EMEI Vehicle G 153 – Group 4.
- dd. Remove the front seats in accordance with EMEI Vehicle G 103 – Group 17.
- ee. Remove the parking brake cable in accordance with EMEI Vehicle G 103 – Group 12.
- ff. Remove the bolts securing the jerrican holders to the chassis and body.
- gg. Remove the ten bolts securing the body to the rear crossmember (Figure 11).

UNCONTROLLED IF PRINTED

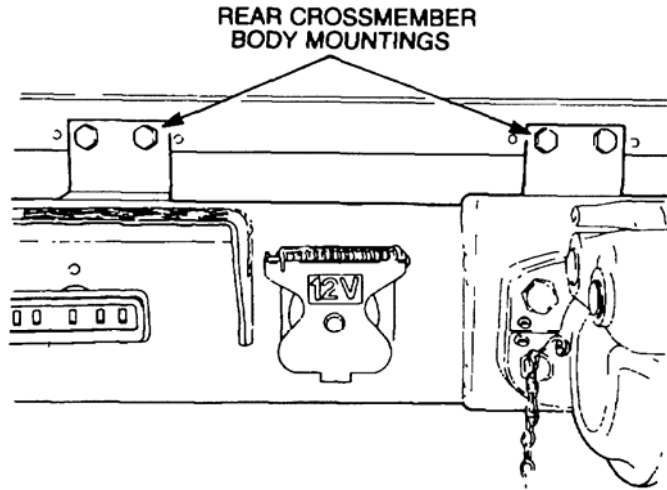

**Figure 11 Rear Body Mountings**

- hh. Remove the bolts, nuts and washers securing the rear body crossmember to the chassis frame (Figure 12).

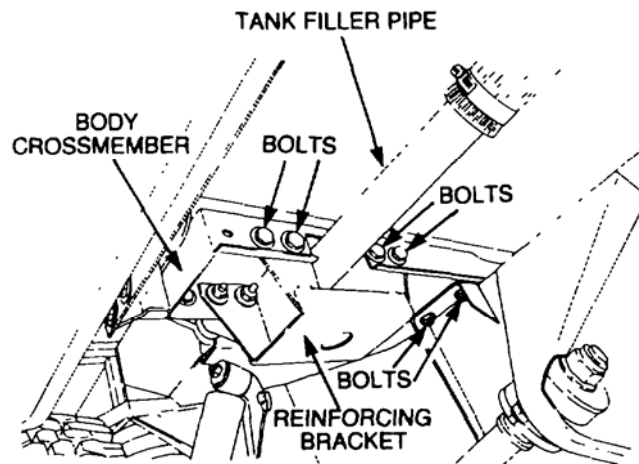

**Figure 12 Removal of the Body Brace Support**

- ii. Remove the bolts securing the rear body restraining stays (Figure 13) to the chassis.

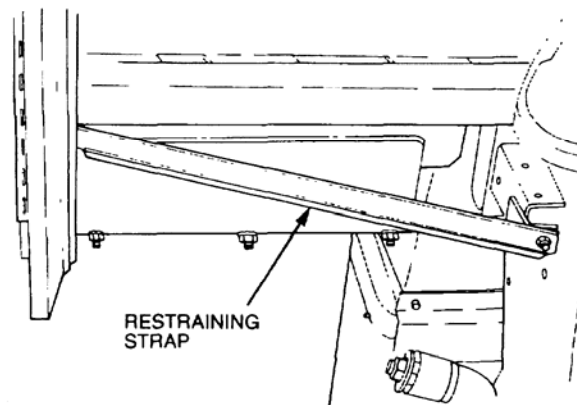

**Figure 13 Removal of the Body Restraining Strap**

- jj. Remove the bolts securing the front body mountings to the chassis brackets (Figure 14).

UNCONTROLLED IF PRINTED

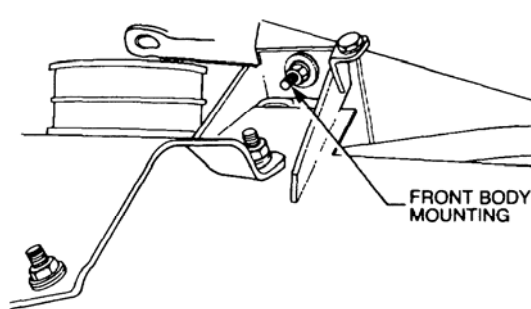

**Figure 14 Removal of the Front Body Mounting**

- kk.** Remove the nuts, washers and bolts from the reinforcing bracket fitted to the detachable body crossmember, as shown in Figure 12, and remove the bracket from the crossmember.
- ll.** Remove the eight bolts, nuts and washers securing the body mounting brackets to the chassis frame outrigger (Figure 15), then repeat the procedure for the opposite side. Remove the battery earth cable from the left side outrigger.

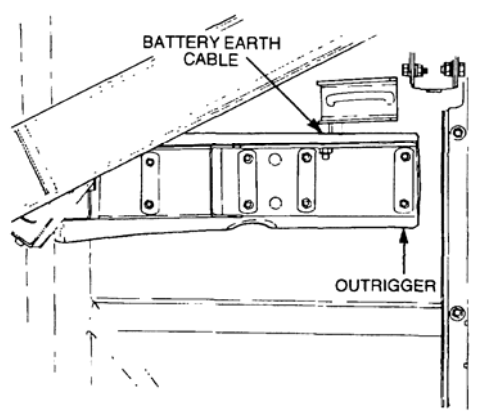

**Figure 15 Removal of the Body Mounting Bolts**

- mm.** Check that all the mounting bolts and cables have been removed or disconnected, then, using suitable overhead lifting equipment, with a minimum safe working load of 500 kg, carefully raise the body assembly off the chassis frame and lower the body onto suitable axle stands.
- nn.** Remove the bolts securing the firewall toe box brackets to the chassis (Figure 16), and using suitable overhead lifting equipment, with a minimum safe working load of 500 kg, attach two slings to the windscreen mounting holes.
- oo.** Remove the bolts securing the firewall to the outriggers and raise the firewall off the chassis frame.

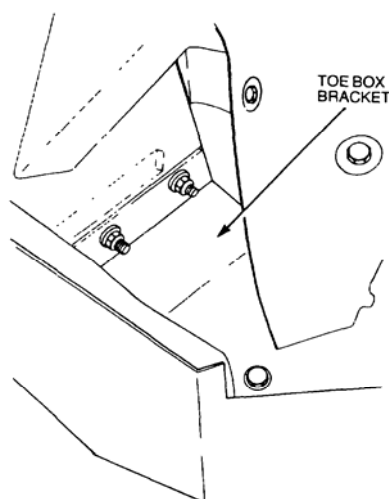

**Figure 16 Removal of the Toe-box Bracket**

UNCONTROLLED IF PRINTED

- pp. Remove the heater assembly in accordance with EMEI Vehicle G 103 – Group 18.
- qq. Remove the clutch master cylinder and pedal bracket in accordance with EMEI Vehicle G 103 – Group 5.
- rr. Remove the brake servo cylinder and pedal bracket in accordance with EMEI Vehicle G 103 – Group 12.
- ss. Remove the dashboard in accordance with EMEI Vehicle G 104-2 – Group 17.
- tt. Remove the steering column in accordance with EMEI Vehicle G 104-1 – Group 14.
- uu. Remove the fuel tank in accordance with EMEI Vehicle G 103 – Group 4.

**NOTE**

The engine and transmission can be removed as an assembly if required.

- vv. Remove the engine in accordance with EMEI Vehicle G 104-1 – Group 1.
  - ww. Remove the transmission in accordance with EMEI Vehicle G 104-1 – Group 6.
  - xx. Remove the wiring harnesses in accordance with EMEI Vehicle G 104-2 – Group 15.
- 14. Inspection.** Inspect the body for corrosion, dents, cracks and loose rivets. Repair or replace as necessary.
- 15. Installation.** Install the body as follows:
- a. Install the wiring harnesses in accordance with EMEI Vehicle G 104-2 – Group 15.
  - b. Install the transmission in accordance with EMEI Vehicle G 104-1 – Group 6.
  - c. Install the engine in accordance with EMEI Vehicle G 104-1 – Group 1.
  - d. Install the fuel tank in accordance with EMEI Vehicle G 103 – Group 4.
  - e. Install the steering column in accordance with EMEI Vehicle G 104-1 – Group 14.
  - f. Install the dashboard in accordance with EMEI Vehicle G 104-2 – Group 17.
  - g. Install the brake servo cylinder and pedal bracket in accordance with EMEI Vehicle G 103 – Group 12.
  - h. Install the clutch master cylinder and pedal bracket in accordance with EMEI Vehicle G 103 – Group 5.
  - i. Install the heater assembly in accordance with EMEI Vehicle G 103 – Group 18.
  - j. Attach the lifting sling to the firewall windscreen mounting holes, then using the lifting equipment, position the firewall on the chassis frame. Install the bolts, washers and nuts that retain the firewall to the outriggers, and tighten them securely. Remove the sling and lifting equipment.
  - k. Using suitable overhead lifting equipment, with a minimum safe working load of 500 kg, position the body assembly on the chassis frame. With the weight of the body still supported by the lifting equipment, ensure that all the mounting brackets are positioned correctly. Fit the bolts, washers and nuts that secure the brackets to the chassis frame, but do not tighten them at this stage. Remove the slings and lifting equipment.
  - l. Install the eight nuts, washers and bolts retaining the body mounting brackets to the chassis frame outrigger (Figure 15) and tighten them securely. Repeat the procedure for the opposite side, and tighten all remaining body mounting bolts securely.
  - m. Install the battery earth cable on the left side outrigger and tighten the retaining bolt, washer and nut securely.
  - n. Install the bolts that secure the toe-box brackets to the chassis (Figure 16).
  - o. Install the bolts securing the front body mountings to the chassis brackets (Figure 14) and tighten them securely.
  - p. Install the nuts, washers and bolts retaining the rear body restraining stays (Figure 13).
  - q. Install the nuts, washers and bolts retaining the rear body support brace to the chassis frame (Figure 12).

- r. Install the jerrican holders on the chassis, fit the bolts, washers and nuts and them tighten securely.
- s. Install the parking brake cable in accordance with EMEI Vehicle G 103 – Group 12.
- t. Install the front seats and runners and tighten the retaining bolts securely.
- u. Fit the fuel tank breather and filler neck hoses in accordance with EMEI Vehicle G 153 – Group 4 and tighten the hose clamps securely.
- v. Connect the steering column at the firewall in accordance with EMEI Vehicle G 104-1 – Group 14.
- w. Connect the main wiring harness at the firewall in accordance with EMEI Vehicle G 104-2 – Group 15.
- x. Install the speedometer cable in accordance with EMEI Vehicle G 103 – Group 6.
- y. Connect the axle and gearbox breather hoses in accordance with EMEI Vehicle G 103 – Group 6 and tighten the banjo bolts securely.
- z. Install the exhaust system in accordance with EMEI Vehicle G 104-1 – Group 3.
- aa. Install the windscreen in accordance with EMEI Vehicle G 103 – Group 17.
- bb. Using suitable overhead lifting equipment, with a minimum safe working load of 500 kg, install the upper body panels onto the vehicle. Fit the ten bolts, nuts and washers that retain the upper body panels to the lower body frame (Figure 8) and tighten them securely.
- cc. Fit the four screws that secure the roof panel to the top of pillars B (Figure 7) and C.
- dd. Fit a new sealing strip to the top of the windscreen frame, then install the eight bolts that secure the roof panel (Figure 7) to the windscreen frame.
- ee. Install the rear and inward facing seats in accordance with EMEI Vehicle G 143 – Group 17.
- ff. Install the sill panels and stays and secure them with the bolts, nuts and washers. Fit the wheel arch extensions on the sills and secure them with the plastic clips.
- gg. Install the rear floor panel and secure it with the eleven screws.
- hh. Install the rear cargo area mat, then tighten the mat retaining plate bolts.
- ii. Install the front floor panels in accordance with EMEI Vehicle G 103 – Group 17.
- jj. Install the rear mat and retaining plates (Figure 5) and secure them with the three screws.
- kk. Install the rear doors in accordance with EMEI Vehicle G 153 – Group 17.
- ll. Install the front doors in accordance with EMEI Vehicle G 153 – Group 17.
- mm. Install the radiator in accordance with EMEI Vehicle G 103 – Group 2.
- nn. Install the grille in accordance with EMEI Vehicle G 103 – Group 17.
- oo. Install the mudguards in accordance with EMEI Vehicle G 104-1 – Group 17.
- pp. Install the bonnet in accordance with EMEI Vehicle G 104-1 – Group 17.
- qq. Install the brushguard in accordance with EMEI Vehicle G 103 – Group 16.
- rr. Fit both windscreen wiper arms and blades.
- ss. Install the vehicle battery and cables in accordance with EMEI Vehicle G 103 – Group 15.

### **Tropical Roof**

- 16. Removal.** Using a suitable drill, remove the twenty four rivets securing the tropical roof to the roof panel, then remove the tropical roof.
- 17. Cleaning and Inspection.** Inspect the tropical roof for:
  - a. Roof Panel Damage.** Inspect the roof within a 100 mm diameter circle centered on the securing rivet hole for damage, cracks or any other weakness that could reduce the ability of the rivet to adequately secure the roof to the vehicle. If the roof fails inspection it is to be replaced.

- b. **The Number of Rivets and Vacant Holes.** The total number of rivets and vacant holes is not to exceed forty eight. The total number of rivets is not to be less than twenty four. The leading edge of the roof is to be secured by a minimum of six rivets. If the roof does not meet these criteria it is to be replaced.
- c. **Correct Rivets.** Rivets that cannot be confirmed as correct are to be replaced. New rivets are made of aluminium, have a stem diameter of 5.3 mm, and a length of 21.7 mm. Rivets that have not been fitted should have three slits in the stem to assist with the mushrooming action when they are installed. When fitted to a vehicle they can be identified by measuring the head diameter which should be 11.5 mm and have a head thickness of 2 mm.
- d. **Loose Rivets.** Rivets that appear loose are to be removed and replaced. Replacement rivets are to be fitted to existing holes except where the hole diameter exceeds 6.0 mm. If an existing hole cannot be used, a new 5.3 to 5.4 mm diameter hole is to be drilled 25 mm away from the original hole, on the centre line of the stiffener rail. The correct type of replacement rivets are to be fitted in the new hole and any unused or old holes filled with translucent silicone sealer and smoothed off.
- e. **Roof Replacement.** If a tropical roof panel has been removed for replacement, the condition of the pop rivet holes in the longitudinal stiffener rails must be inspected before they are used to attach the new panel. Existing holes are not to be reused if they are greater than 6.0 mm diameter. If required, mark the position of the new hole 25 mm away from the original hole along the centre line of the stiffener rail. Mark the corresponding position on the new panel and drill a 5.3 to 5.4 mm diameter hole through both the panel and stiffener rail when the panel has been positioned on the vehicle.

**18. Installation.** Position the tropical roof on the roof panel, aligning the rivet holes, then secure the tropical roof with new pop rivets.

UNCONTROLLED IF PRINTED

**END**

Distribution List: **VEH G 16.4 – Code 4** (Maint Level)  
(Sponsor: LV SPO, Lt B Vehicles)  
(Authority: TRAMM)