

7610-66-128-5939



AUSTRALIAN ARMY

TECHNICAL MANUAL

USER HANDBOOK

TRUCK, ELECTRONIC REPAIR,
LIGHT, MC2

2320-66-128-5310
(LIABILITY CODE No. 73220/01)
Specification Army (Aust) 6434
Headquarters Logistic Command
1990

(D.M.M. Francis)
Major General
Assistant Chief of the
General Staff
Materiel — Army

Issued by Command
of the Chief of the
General Staff

AMENDMENT RECORD

Amendment No.	Actioned by: Signature and Date

SYNOPSIS

The Truck, Electronic Repair, Light, MC2 is a six-wheeled Army vehicle designed specifically for military use. The vehicle is based on the Land Rover 110 Series commercial vehicle, but with an extended chassis and an additional axle. The truck, electronic repair, is a constant four-wheel drive, with selective six-wheel drive for negotiating difficult terrain. Vehicle slinging, tie-down and recovery points are incorporated in the chassis.

The electronic repair module is a self-contained structure which can be fitted to the cab/chassis of a Truck, Cargo, Light, MC2 in place of the standard cargo tray body.

The module provides an environmentally controlled work area for two tradesmen, and includes benches (with a top finish of anti-static material and non-conductive edging), storage space, air-conditioning and suitable lighting.

The vehicle has a range of approximately 600 km on first class roads, and 480 km on second class roads. Cross country ranges vary depending on terrain. The rated gross vehicle mass (GVM) and gross combined mass (GCM) for both highway and cross country conditions is 5.6 tonne and 7.1 tonne respectively.

WARNING

Page No.

WARNING

56

Should the engine become overheated, park the vehicle in a safe working area and allow the engine to cool before attempting repairs to, or refilling of, the cooling system.

WARNING

58

Because of the excellent rough terrain characteristics of this vehicle, drivers are cautioned to maintain a safe speed for the conditions encountered, **especially when towing a trailer or utilizing tyre chains.**

WARNING

59

The parking brake acts on the transmission, not the rear wheels. The differential lock must be engaged and the wheels chocked to enable the vehicle to be raised safely.

WARNING

61

When using rear lift recovery, extreme caution must be observed.

WARNING

66

Ensure that the bonnet support stay is properly locked before releasing the bonnet.

WARNING

95,101

The vehicle is to be earthed using the external earth spike prior to external 415/240 volt power sources being connected to the vehicle.

WARNING

This vehicle is painted in polyurethane paint. Precautions should be taken prior to carrying out repairs which include painting, sanding, scraping or welding. For safety precautions refer to Introduction Into Service Instruction, Materiel Management Policy Statement, Painting Policy for Vehicles and Equipment or relevant EMEI.

LIST OF CONTENTS

Preliminary Pages		Page No.
Synopsis		iii
Warnings.....		iv
List of contents.....		v
List of illustrations		vi
List of tables		viii
Associated publications		ix
Frontispiece.....		x
Maintenance supply item (MSI) identification		xi

Chapter	Section	Heading	Page No.
1		General description.....	1
	1	Data summary.....	2
	2	Shipping and transportation data.....	12
	3	Equipment description	15
2		Operating instructions.....	37
	1	Warranty and repair.....	38
	2	Vehicle operation	54
3		Operator servicing.....	63
	1	Servicing.....	64
	2	Lubrication	79
4		Electronic repair module.....	89
	1	Equipment description	90
	2	Equipment operating instructions	101
		Complete Equipment Schedule (CES).....	103
		Index	110

LIST OF ILLUSTRATIONS

Fig. No.	Title	Page No.
1-1	Truck, Electronic Repair, Light, MC2 — front view	x
1-2	Truck, Electronic Repair, Light, MC2 — rear view	x
1-3	Slings and tie-down points.....	14
1-4	Air temperature and distribution controls	18
1-5	Combination switch operation	20
1-6	Warning lights	22
1-7	Windscreen washer and wiper control.....	23
1-8	Hazard warning and cab dome light switches	24
1-9	Bonnet safety catch.....	24
1-10	Main lighting switch	25
1-11	Gear change pattern	26
1-12	Transfer case shift pattern.....	26
1-13	Fuses	27
1-14	Seat adjustment.....	27
1-15	Rear window.....	28
1-16	Roof hatch.....	29
1-17	Rear side window.....	29
1-18	Spare wheel lowering	30
1-19	Vehicle nomenclature plate	31
1-20	Servicing data and tyre pressure plate	32
1-21	Shipping data plate	32
1-22	Towing and dyno test data plate	33
1-23	Jacking procedure plate.....	33
1-24	Instruments, electrical accessories and controls.....	35
2-1	Starter switch positions.....	55
2-2	Flywheel housing drain.....	57
2-3	Jack position — front wheels.....	60
2-4	Jack position — rear wheels.....	60
3-1	Thermostat housing.....	67
3-2	Bleeding the fuel system.....	68
3-3	Lubrication and oil drain/refill points.....	80
3-4	Engine right hand side.....	80
3-5	Oil filter removal	81
3-6	Transmission drain and fill plugs	82
3-7	Transfer case drain and fill plugs	82
3-8	Intermediate axle drain and fill plugs	83
3-9	Rear axle drain and fill plugs.....	83
3-10	Swivel pin housing drain and fill plugs	84
3-11	Fuel filter.....	85
3-12	Fuel sedimenters	85

Fig. No.	Title	Page No.
3-13	Air cleaner removal	86
3-14	Air cleaner elements	86
3-15	Brake reservoir	87
3-16	Clutch reservoir	88
3-17	Jockey pulley lubrication.....	88
4-1	Ceiling light switches.....	90
4-2	Module 24 volt lighting	91
4-3	High level rear lights.....	91
4-4	Fan assisted heater	92
4-5	Air conditioning unit.....	92
4-6	Air conditioning compressor.....	93
4-7	Circuit breaker and power selection panel.....	93
4-8	Rear step.....	95
4-9	Power inlet sockets	95
4-10	First aid kit and fire extinguisher location	96
4-11	Module interior view	99
4-12	Side bench.....	101
4-13	Bin pack mounting frame	102

LIST OF TABLES

Table No.	Title	Page No.
1-1	Location of identification numbers on MSI's.....	xi
2-1	Pro-rata warranty.....	38
2-2	JRA State offices.....	41
2-3	Land Rover dealers.....	42
3-1	Daily tasks.....	69
3-2	Fortnightly tasks.....	70
3-3	Initial servicing.....	71
3-4	Minor servicing.....	72
3-5	Major servicing.....	75
3-6	List of lubricants.....	79

ASSOCIATED PUBLICATIONS

1. Standing Orders for Vehicle Operation and Servicing
2. Australian Army Books:
TGM 120 Record Book for Service Equipment — Army
3. Complete Equipment Schedules (CES):
(a) SCES 12107/1 } Truck, Electronic Repair,
(b) Equipment Kit SCES 12122/1 } Light, MC2
4. Block Scale 2406/31 Issue 1 — Special Tools for RAEME – B Vehicles – Truck, Cargo, Light, MC2 (Land Rover Model 110)
5. EMEI VEH A 029 — Servicing of B Vehicles
6. EMEI VEH A 119-22 — Repair of Vehicles Under Warranty Agreement — Policy Instruction
7. EMEI VEH G 250 — Data Summary (Truck, Electronic Repair, Light, MC2)
8. EMEI VEH G 202 — Technical Description (Truck, Cargo, Light, MC2)
9. EMEI VEH G 252 — Technical Description (Truck, Electronic Repair, Light, MC2)
10. EMEI VEH G 203 — Unit Repair (Truck, Cargo, Light, MC2)
11. EMEI VEH G 253 — Unit Repair (Truck, Electronic Repair, Light, MC2)
12. EMEI VEH G 204 — Field Repair (Truck, Cargo, Light, MC2)
13. EMEI VEH G 204-1 — Base Repair (Truck, Cargo, Light, MC2)
14. EMEI VEH G 254-1 — Field and Base Repair (Truck, Electronic Repair, Light, MC2)
15. EMEI WKSP E 652 — Occupational Health and Safety (Polyurethane paint)
16. EMEI VEH G 209 — Servicing Instruction
17. Repair Parts Scale 02210

FRONTISPIECE

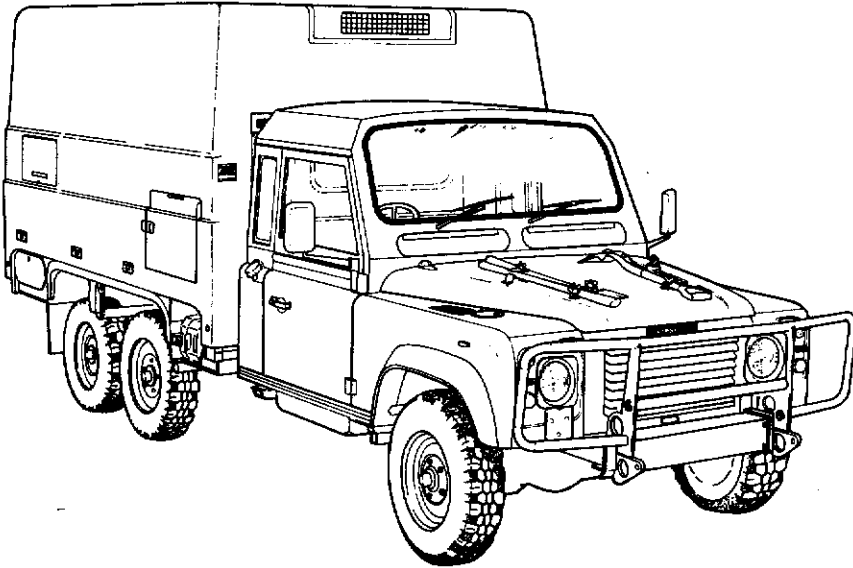

Figure 1-1 Truck, Electronic Repair, Light, MC2 — front view

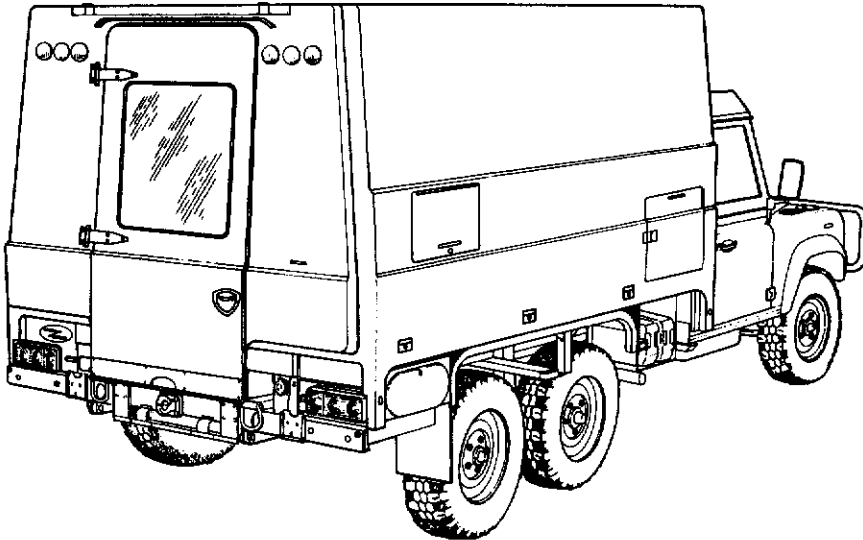

Figure 1-2 Truck, Electronic Repair, Light, MC2 — rear view

MAINTENANCE SUPPLY ITEM (MSI) IDENTIFICATION

Table 1-1 Location of Identification numbers on MSI's

Chassis No. — Right hand side of the chassis, forward of the spring mounting turret

Chassis nameplate — Left hand seat box, in the cab

Engine No. — Left hand side of the engine block

Injection pump identification — Side of the pump

Transmission and transfer case — Rear of the transfer case

Repair module — Right hand rear

Air conditioning compressor — Front outer mounting point

CHAPTER 1

GENERAL DESCRIPTION

SECTION 1 — DATA SUMMARY

**SECTION 2 — SHIPPING AND
TRANSPORTATION
DATA**

**SECTION 3 — EQUIPMENT
DESCRIPTION**

SECTION 1

DATA SUMMARY

NOTE

Throughout this manual all references to left hand (LH) and right hand (RH) are as viewed from the rear of the vehicle looking forward.

Truck Model No.	Land Rover 110 6 x 6
1. Engine	
Manufacturer	Isuzu
Type	4BD1 TRB-G series, turbocharged, four cylinder in line, overhead valve four cycle direct injection diesel engine
Displacement	3.856 litres
Bore	102 mm
Stroke	118 mm
Compression ratio	17:1
Firing order	1 - 3 - 4 - 2
Power	90 kW @ 3000 rpm
Maximum torque	314 Nm @ 2200 rpm
No load maximum	3600 ± 100 rpm
Engine idle speed	650 ± 20 rpm
Oil capacity	8.5 litre including filters
Oil filters	External, full flow, spin on
Oil pressure	390-581 kPa @ 2400 rpm
Oil cooler	Water cooled, plate and tube type

Engine dry weight	
— With 24 volt alternator	350 kg
— Without 24 volt system	322.5 kg
Turbocharger	Water cooled, Garret, model ATD-T25

2. Cooling system

Type	Pressurised spill return system with thermostat control, pump and fan assisted
Capacity	12.8 litres
Thermostat	Downward opening wax element type incorporating a by-pass shut off valve. Opening temperature 82°C
Coolant	Water with 5% Alfloc 2001 inhibitor

3. Engine accessory drive

12 volt system

Type	Single Vee-belt
Tension	Approximately 10-15 mm deflection, midway along the longest span using moderate thumb force

24 volt system

Type	Single Vee-belt
Tension	Approximately 10-15 mm deflection midway along the longest span using moderate thumb force

4. Fuel system

Fuel pump	Diesel Kiki (Bosch) in-line Type A model 550k with automatic timer
Governor	RLD-K mechanical
Transfer pump	KE mechanical with gauze intake filter
Injectors	Four-hole spray type

Main filter	Inlet manifold mounted, spin-on type
Sedimenter	Two chassis mounted CAV SS type sedimenters are connected in parallel
Fuel tanks	Two, 62 litre tanks connected in parallel and independent of each other, tank selection by dash mounted switch

5. Engine starter

Manufacturer	Mitsubishi
Type	Waterproof, gear reduction (electric powered)

6. Clutch

Manufacturer	Repco/Isuzu
Type	Hydraulically operated single dry plate and diaphragm spring
Free travel (pedal)	6 mm minimum

7. Transmission

Manufacturer	Land Rover										
Type	Model LT95A, four forward, one reverse, synchromesh on all forward gears. Incorporates an integral transfer case										
Ratios	<table> <tr> <td>First gear</td> <td>4.069:1</td> </tr> <tr> <td>Second gear</td> <td>2.448:1</td> </tr> <tr> <td>Third gear</td> <td>1.505:1</td> </tr> <tr> <td>Fourth gear</td> <td>1.000:1</td> </tr> <tr> <td>Reverse gear</td> <td>3.664:1</td> </tr> </table>	First gear	4.069:1	Second gear	2.448:1	Third gear	1.505:1	Fourth gear	1.000:1	Reverse gear	3.664:1
First gear	4.069:1										
Second gear	2.448:1										
Third gear	1.505:1										
Fourth gear	1.000:1										
Reverse gear	3.664:1										

8. Transfer case

Manufacturer	Land Rover
Type	High and low gear ratios operating on the main transmission output. The

front and intermediate axles are permanently engaged via a differential in the transfer case. The rear axle is automatically engaged when the transfer case differential is locked — for traversing difficult terrain

Ratios	High range	0.996:1
	Low-range	3.321:1

9. Front axle

Manufacturer	Land Rover
Type	Fully floating spiral bevel steerable drive axle with enclosed outboard constant velocity joints and four pinion differential
Ratio	4.7:1
Track	1698 mm
Design load rating	1900 kg

10. Rear axles

Manufacturer	GKN
Type	Salisbury fully floating hypoid bevel drive, four pinion differential
Ratio	4.7:1
Track	1698 mm
Design load rating	2050 kg

11. Propeller shafts

Type — Front

An open shaft, incorporating a Hookes type universal joint at either end. Variations in the length of the shaft is achieved by employing a splined sliding joint between the two universal joints

—Intermediate

An open shaft, incorporating a Hookes type universal joint at either end. Variations in the length of the

shaft is achieved by employing a splined sliding joint between the two universal joints

—Rear

A two piece open shaft incorporating a Hookes type universal joint at either end. The centre section of the shaft is mounted via a bearing to the chassis frame and the articulation of the rear section of the shaft is achieved through the use of a double Hookes joint, and a splined sliding joint

12. Front suspension

Type

Radius arms with Panhard rod located live axle with vertically mounted double acting telescopic shock absorbers mounted inside single rate coil springs

Design load rating

1900 kg

13. Rear suspension

Type

Consists of two live axles located by four semi-elliptic springs. These springs are so mounted that the ends, between the axles overlap each other and are articulated by a load sharing rocker beam connected to the chassis. Axle bump and rebound travel is controlled by chassis mounted pads and cables. Suspension dampening is by four hydraulic shock absorbers

Design load rating

4100 kg

14. Steering

Manufacturer

Adwest

Type

Power assisted variable ratio worm and roller type utilizing a gear driven pump, mounted on the engine and a remote hydraulic reservoir

Turning circle	
Between kerbs	16.8 metres (nominal)
Between walls	17.2 metres (nominal)

15. Brakes

Type	Hydraulic split system with front disc and rear drum brakes, foot pedal actuated
Parking brake	Cable operated, transmission mounted drum brake
Warning devices	Dash mounted globes indicating front brake pad lining depth (actuated at 3 mm thickness) a failed hydraulic circuit, and parking brake applied

16. Chassis

Type	Hot dipped galvanized welded box section steel with welded box section crossmembers
Wheelbase	
Front to intermediate axle	3040 mm
Front to rear axle	3940 mm

17. Wheels and tyres

Rim type and size	Ventilated disc, 6F x 16
Tyre size	7.50-R-16LT 10 ply Olympic Steeltrek with 105 pattern
Tyre pressure (cold)	Highway: front 350 kPa (50 psi) intermediate 350 kPa (50 psi) rear 350 kPa (50 psi) Cross country: front 275 kPa (40 psi) intermediate 275 kPa (40 psi) rear 275 kPa (40 psi)

Sand:

front 225 kPa (33 psi)

intermediate 225 kPa (33 psi)

rear 225 kPa (33 psi)

18. Electrical system

Type	The vehicle is fitted with 12 volt, 24 volt, 240 volt and 415V electrical systems
12 volt system	12 volt negative earth
Battery	12 volt cold cranking performance of approximately 410 amps, located in the engine compartment
Alternator	Hitachi, 12 volt — 70 amp
24 volt system	24 volt negative earth
Batteries	Two 12 volt, 93 ah deep cycle batteries located in a box on the left hand side of the chassis
Alternator	Bosch 24 volt, 55 amp
240 volt/415 volt system	240 volt single phase/415 volt three phase
Mains input or field generator	Four switched 240 volt, AC, single phase, 10 amp Two switched 240 volt, AC, single phase, 15 amp
Battery charger	Arlec 240 volt input, three voltage (6/12/24 volt) output with high and low charging rate
Air conditioner motor	240 volt, single phase, 50 Hz, 2.2 kW @ 1500 rpm

**19. Lighting, external
12 volt**

Headlights, high/low

Location, quantity and wattage

Front of vehicle, 2 off, 60/55 watt
Halogen

Park lights

Front of vehicle, 2 off, 5 watt

Stop and tail lights

Rear of vehicle, 2 off, 21/6 watt

High level stop and tail lights

Top of module at rear, 2 off, 10/5 watt

Turn indicator lights

Each corner of vehicle, 4 off, 21 watt

High level turn indicator lights

Top of rear door, 2 off, 10 watt

Side indicator lights

Front mudguards, 2 off, 4 watt

Reverse lights

Rear of vehicle, 2 off, 10 watt

High level reverse lights

Top of module at rear, 2 off, 18 watt

**20. Lighting, internal
12 volt**

Location, quantity and wattage

Dome light

Roof of cab, 1 off, 21 watt

Map light

Left hand side of instrument panel 1
off, 5 watt Halogen

Instrument lights— except
speedo

Instrument panel, 3 off, 2 watt

Speedometer light

Instrument panel, 2 off, 3 watt

Warning lights — except
low fuel

Instrument panel, 10 off, 1.2 watt

Low fuel light

Instrument panel, 1 off, 3 watt

Hazard switch warning light

Dashboard, 1 off, 0.6 watt

**21. Lighting, internal
24 volt**

Location, quantity and wattage

Emergency light

Roof of module, 4 off, 18 watt

Blackout

Ceiling, 2 off, 18 watt

22. Lighting, internal 240 volt	Location, quantity and wattage
--	---------------------------------------

Ceiling light	Roof of module, fluorescent tube, 4 off, 20 watt
---------------	---

23. Lighting, military	Location, quantity and wattage
-------------------------------	---------------------------------------

Blackout lights	Front and rear of vehicle 4 off, replaceable module
-----------------	--

Convoy light	Rear of vehicle, 1 off, 2 watt
--------------	--------------------------------

Reduced headlights	Front of vehicle, 2 off, 18 watt
--------------------	----------------------------------

Ancillary circuits	Couplings are provided at the rear of the vehicle to accept NATO and civil- ian trailer connectors
--------------------	--

24. Fuses	Rating (continuous)
------------------	----------------------------

Located inside the cab, centre
console, behind protective panel

Headlights	4 off, 8 amp
------------	--------------

Park lights	2.5 amp
-------------	---------

Horn, dome light	10 amp
------------------	--------

Hazard lights	10 amp
---------------	--------

Reverse lights	10 amp
----------------	--------

Windscreen wiper, washer	12 amp
--------------------------	--------

Fan	10 amp
-----	--------

Spare	8 amp
-------	-------

Stop lights, instruments, turn indicators	10 amp
--	--------

Stop/Start Control Motor	10 amp
--------------------------	--------

Blackout lights	8 amp
-----------------	-------

Reduced headlights	8 amp
--------------------	-------

Located under bonnet, near
brake master cylinder/
booster

25. Performance

Gradeability (cross-country laden) both directions	60 per cent gradient (31 degree slope)
Range of operation	600 km (first class roads) approx. 480 km (second class roads) approx.
Fuel consumption	22 litres per 100 km (highway laden) 27 litres per 100 km (second class laden) Fuel tank capacity 62 litres each

26. Carrying capacity 3 (including driver)

27. Module Internal dimensions

Height	1800 mm
Width	2085 mm
Rear door width	740 mm
Rear door height	1600 mm
Length	3100 mm
Height of floor from road	
— Laden	725 mm
— Unladen	740 mm

SECTION 2

SHIPPING AND TRANSPORTATION DATA

28. Dimensions

Overall length		6001 mm
Wheelbase	— Front axle to intermediate axle	3040 mm
	— Front axle to rear axle	3940 mm
Overall width	— Over mirrors	2440 mm
	— Reduced	2185 mm
Overall height	— Laden	2560 mm
	— Unladen	2590 mm
Track	— Front	1698 mm
	— Rear	1698 mm
Height of module from ground		
	— Laden	710 mm
	— Unladen	740 mm
Rear axle to rear of vehicle overhang		1183 mm
Towing pintle height	— Laden	700 mm
	— Unladen	730 mm
Mass (Unladen)		
	— Front	1700 kg
	— Intermediate	1475 kg
	— Rear	1475 kg
	— Total	4650 kg
Mass (Laden)		
	— Front	1750 kg
	— Intermediate	2100 kg
	— Rear	2100 kg
	— Total	5600 kg

29. Capacities

Equipment	DEF (AUST) 206	METRIC (litres)
Engine system (including filters)	OMD-115	8.5
Cooling system (including inhibitor)		12.8
Transmission	OMD-115	2.7
Transfer case (without PTO)	OMD-115	3.2
Front axle	OEP-220	1.7
Intermediate axle	OEP-220	2.3
Rear axle	OEP-220	2.6
Swivel pin housing (each)	OEP-220	0.35
Steering box (including reservoir)	OX 46	1.25
Fuel tank — Right hand		62
— Left hand		62

NOTE

See EMEI VEH G 209 for list of approved lubricants.

30. Fording depth

Unprepared vehicle	500 mm
Limiting features (over 500 mm)	Cooling fan
Prepared vehicle	No facility available, as for unprepared vehicle

31. Bridge classification

Solo unladen 6

32. Ground clearance

Unladen 215 mm

Limiting feature Rear differential housings

33. Transportability

Railway loading gauges (Local authorities must be consulted)

Rail authority	Gauge	Maximum rolling stock height
Commonwealth	1435 mm	2532 mm
Commonwealth	1067 mm	2532 mm
New South Wales	1435 mm	2182 mm
Queensland	1067 mm	1806 mm
South Australia	1600 mm	2075 mm
South Australia	1435 mm	2075 mm
South Australia	1067 mm	1761 mm
Tasmania	1067 mm	1992 mm
Victoria	1600 mm	2182 mm
Victoria	1435 mm	2182 mm
Western Australia	1435 mm	2532 mm
Western Australia	1067 mm	1973 mm

34. Slings and tie-down points are illustrated in Fig. 1-3.

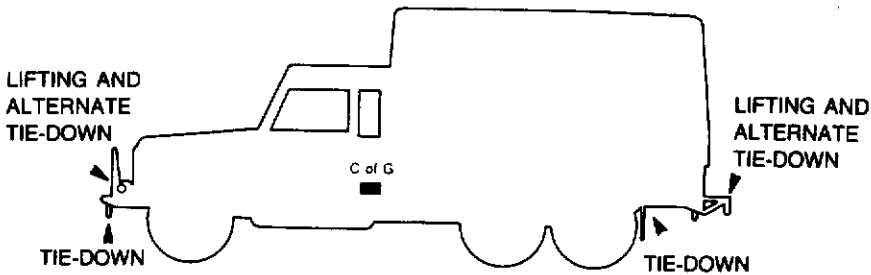

Figure 1-3 Slings and tie-down points

35. Approach and departure angles

Approach angle	— Unladen	45 degrees
	— Laden	41 degrees
	— Limiting feature	Tie-down points
Departure angle	— Unladen	33 degrees
	— Laden	30 degrees
	— Limiting feature	Tie-down points
Ramp breakover angle	— Unladen	148 degrees
	— Laden	152 degrees
	— Limiting feature	Chassis rail

SECTION 3

EQUIPMENT DESCRIPTION

Introduction

36. The truck, electronic repair, light, MC2 has been designed specifically for military use. The vehicle provides an environmentally controlled work station for two tradesmen to carry out repairs on electronic componentry by utilizing the specialist equipment, tools, machinery and spare parts stowed within the module. The permanent four-wheel drive and selective six-wheel drive of the vehicle, enables access to be gained to most repair sites.

Operational and logistic concept

37. The electronic repair vehicle is designed to be utilized as either a part of a Main or Forward Repair Group where the vehicle may remain stationary for several days, or as an individual station, moving to the site of the repair, where tasks are of short duration.

Engine

38. The vehicle is fitted with an Isuzu 3.9 litre 4BD1TRB-G turbo-charged, four cylinder diesel engine which produces 90 kW of power at 3000 rpm and 314 Nm of torque at 2200 rpm.

Transmission

39. The transmission is a heavy duty four-speed all-synchromesh transmission with an integral two-speed transfer case. Clutch and gear operations are manual and are without power assistance.

Transfer case

40. The transfer case, which is cast as part of the main transmission, provides high and low gear ratios, and four or six-wheel drive capabilities. It has an integral differential fitted to prevent wind up in the drive lines during normal on road conditions and which can be locked to provide a positive drive between the front and rear axles. During off road use, the locking of this differential, by operating a dash mounted switch, automatically engages the vehicle in six-wheel drive. It is imperative that this differential is locked, when crossing difficult terrain, or when conditions may lead to a loss of traction. A high speed range and a low speed range in the transfer case can be

selected by operating a floor mounted lever. The selection of a speed range will not influence the four or six-wheel drive mode.

41. The parking brake operates a single drum brake which is mounted on the rear output shaft of the transfer case.

Steerable front drive axle

42. The vehicle is fitted with a steerable front drive axle, comprising a differential carrier assembly and axles, driving through constant velocity joints to steerable drive ends fitted with hydraulically operated disc brakes.

Front suspension

43. The front suspension utilizes radius arms, a Panhard rod, vertically mounted double acting telescopic shock absorbers and single rate coil springs. Bump stops are provided to limit the upward travel of the suspension, while the shock absorbers limit the downward travel of the axle.

Rear axles

44. The rear axles are Salisbury type, fully floating hypoid bevel drive axles with offset four pinion differentials.

Rear suspension

45. Dual rate semi-elliptic leaf springs linked via shackles to a rubber bushed load sharing rocker beam. Axle movement is controlled by four long travel telescopic shock absorbers and steel cable rebound straps.

Service brakes

46. The vehicle is fitted with a dual circuit hydraulic brake system consisting of two completely separate circuits. The primary circuit supplies the rear drum brakes and the secondary circuit supplies the front disc brakes.

47. Brake pad wear indicators are fitted to the front left hand caliper and will actuate a brake circuit warning light on the dashboard when brake pad lining thickness is reduced to approximately 3 mm. In addition, the warning light will illuminate if fluid loss occurs from either the primary or secondary brake circuit.

Parking brake

48. A single drum brake is mounted on the intermediate axle output shaft of the transfer case. This brake, which is mechanically operated by the parking brake lever in the cab, is completely independent of the foot operated hydraulic brake system.

Instruments, electrical accessories and controls (see Fig. 1-24)

49. Ventilator control (Fig. 1-24 Items 1 and 13)

Two ventilators are provided in the windscreen frame, which may be opened independently by pushing the appropriate control lever downward.

50. Normal, blackout and reduced lighting switch (Fig. 1-24 Item 2)

This three position switch, located on the fascia panel, controls the vehicle lighting as follows:

- a. In the NORMAL or left position, all vehicle lighting operates via the usual controls.
- b. In the BLACKOUT or mid position, all of the NORMAL lighting, with the exception of dash instruments, warning and map reading lights, are switched off. In this mode, the blackout stop lights will function when the brakes are applied, and the blackout marker lights at the front and rear of the vehicle are illuminated. The convoy light also operates in this mode.
- c. In the REDUCED or right position, the reduced head lights are utilized in addition to the blackout lighting. The dash instrument lights and map reading light can also be used.

51. Auxillary power socket (Fig. 1-24 Item 3)

A 2-pin socket is fitted in the dash as a power supply for the vehicle trouble light lead.

52. Panel light dimmer control (Fig. 1-24 Item 4)

The instrument panel light intensity can be adjusted by the dimmer control, which functions irrespective of which of the three modes of lighting is selected. The switch also has an ON-OFF control.

53. Heater fan control switch (Fig. 1-24 Item 5)

A three position rocker switch controls the heater fan as follows:

- a. With the switch in the off position the heating and ventilation system is inoperative.

- b. Low speed or high speed fan operation is provided when the switch is moved down to the first or second stop respectively. Air will be forced into the vehicle then ducted and heated as determined by the air distribution and heat control levers. The fan motor will only operate with the engine running or with the ignition on.

54. Air temperature control (Fig. 1-24 item 6)

The temperature control lever controls the temperature of the air from the heater unit. Moving the lever up in the direction of the blue arrow will cut off the heat, while moving the lever down toward the red arrow will increase the heat (see Fig. 1-4). Action is progressive between the two settings.

55. Air distribution control (Fig. 1-24 item 7)

The air distribution control lever controls the direction of air flow as follows (see Fig. 1-4):

- a. With the lever in the lower position, all air is directed to the windscreen via the demister vents.
- b. With the lever in the mid position, air is directed to the foot level vents as well as the windscreen.
- c. With the lever in the upper position, the air is directed to the foot level vents although a certain amount of air will continue to pass through the demister vents to the windscreen.

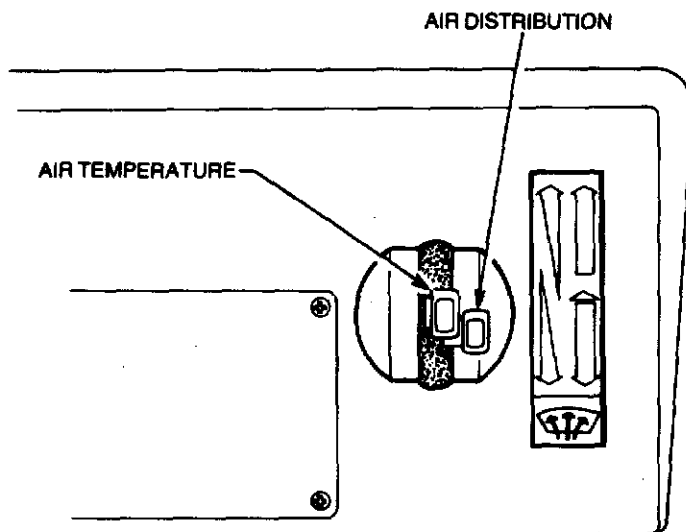

Figure 1-4 Air temperature and distribution controls

56. Fuel switch (Fig. 1-24 Item 8)

A two position toggle switch is located on the dash, which when operated determines from which tank fuel will be drawn.

57. Transfer case control switch (Fig. 1-24 Item 9)

The transfer case is fitted with a differential which allows the vehicle to be operated on road without transmission wind-up. The differential is lockable, to provide positive drive to the axles when necessary, and is controlled by a dash mounted two position switch. The switch should be pushed in for on road use and pulled out when traction is difficult, thereby providing positive six-wheel drive. When changing vehicle wheels the switch must be pulled out (refer to the warning on page 59).

58. Voltmeter — 24 volt (Fig. 1-24 Item 10)

This meter measures the voltage of the modules 24 volt system. With the engine operating above idle speed, the voltmeter needle should be within the 24-28 volt (green band) range. If the voltage indicated is outside this range, and continues after approximately ten minutes, investigation of the 24 volt system is required.

59. Combination switch (Fig. 1-24 Item 11)

The combination switch has six positions and provides control over the headlights, turn indicators and the horn. The combination switch functions are not available during blackout conditions. The switch operates as follows (see Fig. 1-5):

- a. With the switch in the central position (A), the headlights will be dipped.
- b. With the switch pushed away from the driver (B), the headlights will be on high beam.
- c. Pulling the switch toward the driver (C), will flash the headlights. This operation can be achieved at any time, irrespective of other switch positions.
- d. Pushing the switch knob inward (D), will operate the horn.
- e. With the switch in the upper position (E), the right hand turn indicators will flash.
- f. With the switch in the lower position (F), the left hand indicators will flash.

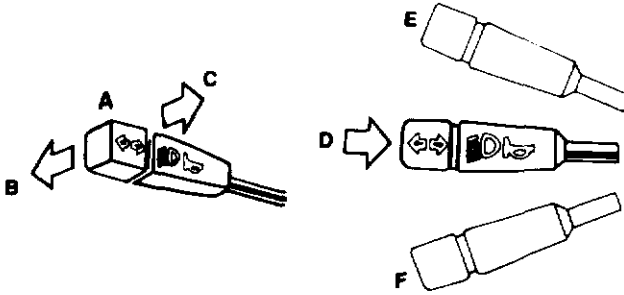

Figure 1-5 Combination switch operation

60. Speedometer and odometer (Fig. 1-24 item 12)

The speedometer indicates the road speed in kilometres per hour and the total distance travelled. A trip meter is incorporated in the speedometer together with its associated reset button.

61. Fuel gauge (Fig. 1-24 item 14)

One fuel gauge services both the left and right hand mounted fuel tanks. The approximate contents of each tank can be assessed by operating a dual purpose dash mounted switch — fuel will only be drawn from the tank indicated.

62. Warning light cluster (Fig. 1-24 item 15)

The warning lights provide a visual indication that a fault has occurred in one or more of the systems represented by the warning lights.

- a. The oil pressure warning light (Fig. 1-6 item 2) indicates when the oil pressure is insufficient for safe engine operation. The light should illuminate when the ignition is turned on and extinguish once normal engine oil pressure is established. If this light illuminates during normal running, the vehicle should be stopped immediately and the cause determined.
- b. The ignition warning light (Fig. 1-6 item 3) indicates a malfunction in the battery charging circuit. The light should illuminate when the ignition is turned on and extinguish once the engine is running.
- c. The brake circuit warning light (Fig. 1-6 item 4) indicates that leakage has occurred from either the front or rear brake circuit. In this case, the light will illuminate when the foot brake is applied. In addition, a brake pad wear indicator is fitted to the front left hand caliper and will actuate the light when the brake pad lining thickness is reduced to approximately 3 mm. Normally, the light will illuminate mo-

mentarily when the ignition is turned on, then extinguish. If the light illuminates during normal running, the vehicle should be stopped immediately and the cause determined.

- d. The turn indicator warning light (Fig. 1-6 item 5) flashes when the turn indicator lights are functioning. Both arrows will flash as the turn indicator is operated by the switch on the steering column. If the light does not flash, there may be a blown globe in the warning light or one of the turn indicators.
- e. The high beam warning light (Fig. 1-6 item 6) illuminates when the headlight high beam has been selected. The light also illuminates when the headlight flasher is used.
- f. The low fuel warning light (Fig. 1-6 item 7) illuminates when there is approximately nine litres of fuel left in either fuel tank and will remain illuminated until the fuel supply is replenished. When cornering, the light may flash intermittently before the fuel reaches the nine litre level.
- g. Both the differential lock warning light (Fig. 1-6 item 8) and the six-wheel drive light (Fig. 1-6 item 1) will illuminate when the transfer case differential lock is engaged. Operation of the differential lock is necessary when traction to one or more wheels is likely to be lost.
- h. The parking brake warning light (Fig. 1-6 item 12) will illuminate if the parking brake is applied while the ignition is on.
- i. The trailer warning light (Fig. 1-6 item 13) provides an indication that the turn indicators on a towed trailer are functioning correctly. The light will flash simultaneously with the vehicle turn indicator warning light when a trailer is connected to the vehicle's NATO socket. When no trailer is used, the light will flash momentarily each time the combination switch is moved up or down. In addition, the trailer warning light will flash when the hazard warning switch is activated.
- j. The park light warning light (Fig. 1-6 item 15) indicates when the park lights have been switched on.
- k. The cold start warning light (Fig. 1-6 item 17) illuminates when the starter switch is in the glow plugs on position.

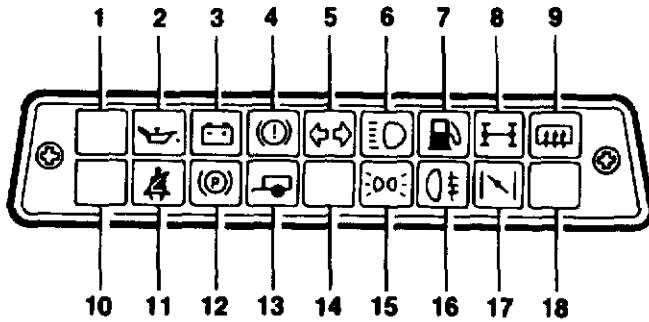

1.	Six-wheel drive	Red
2.	Oil pressure	Red
3.	Ignition	Red
4.	Brake circuit	Red
5.	Turn indicators	Green
6.	High beam	Blue
7.	Low fuel	Amber
8.	Differential lock	Amber
9.	Not used	Amber
10.	Not used	Red
11.	Not used	Red
12.	Parking brake	Red
13.	Trailer	Green
14.	Not used	Green
15.	Park lights on	Green
16.	Not used	Amber
17.	Cold start (glow plugs)	Amber
18.	Not used	Amber

Figure 1-6 Warning lights

63. Coolant temperature gauge (Fig. 1-24 Item 16)

Under normal running conditions, the temperature gauge needle should be within the green band. When operating in high ambient temperatures, with heavy loads or on steep grades at high altitudes, the operating temperature could rise. However, if the needle rises into the red band, the vehicle should be stopped and the cause determined.

64. Voltmeter — 12 volt (Fig. 1-24 item 17)

The voltmeter measures the vehicle system voltage. With the engine running above idle speed, the needle should be within the green band (12-14 volts). A reading above this in the high red band, which continues after approximately ten minutes, is too high and should be investigated. Similarly, a reading in the low red band which continues after approximately ten minutes, with no electrical load switched on, is too low and should also be investigated.

65. Windscreen washer and wiper switch (Fig. 1-24 Item 18)

The windscreen washer and wiper switch is a five position switch, which only operates when the ignition is on. Switch operation is as follows (see Fig. 1-7):

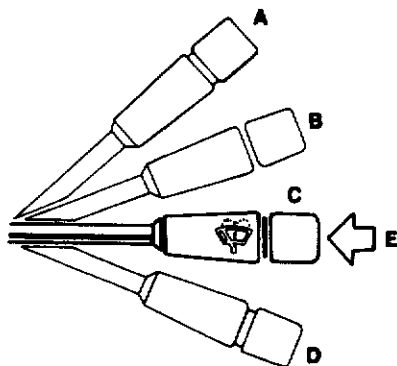

Figure 1-7 Windscreen washer and wiper control

- a. With the switch in the upper position (A), fast wiper action is achieved.
- b. With the switch in the second position (B), slow wiper action is achieved.
- c. With the switch in the third position (C), the wipers are off.
- d. With the switch in the lower position (D), the wipers will operate at the slow speed until the switch is released.
- e. Pushing the switch knob inward (E) will activate the windscreen washer, which will spray water on the windscreen until the knob is released. This can be achieved with the switch on or off.

66. Cab dome light switch (Fig. 1-24 Item 19)

The cab dome light switch is a two position rocker action switch. Pressing the lower section of the switch turns the dome light on and pressing the upper section of the switch turns the dome light off (see Fig. 1-8). The dome light will not function during blackout conditions.

67. Hazard warning switch (Fig. 1-24 Item 20)

The hazard warning switch is a two position rocker action switch. By pressing the lower section of the switch, both the left and right hand turn indicators, together with the side repeaters, flash simultaneously. A globe in the switch also illuminates to indicate that the switch is on. In addition, the trailer warning light will flash when the hazard warn-

ing switch is activated. Pressing the upper section of the switch turns the hazard warning lights off (see Fig. 1-8). Hazard warning lights will not function during blackout conditions.

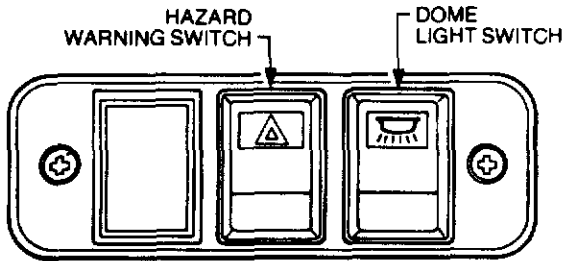

Figure 1-8 Hazard warning and cab dome light switches

68. Hand throttle (Fig. 1-24 item 21)

The hand throttle control can be used to over-ride the accelerator pedal to set engine speed. To utilize the hand throttle, first set the engine speed with the accelerator then pull out the hand throttle and turn the control to lock it in position. The accelerator will over-ride the hand throttle setting when increasing the engine speed. However, when the accelerator is released, the engine will return to the speed set by the hand throttle. To release the hand throttle, turn the knob and push the control fully down to the closed position.

69. Bonnet release (Fig. 1-24 item 22)

The bonnet release handle is located to the right of the steering column, and by pulling the handle, the bonnet catch will release. From the front of the vehicle, lift the safety catch lever and raise the bonnet. Pull the support stay forward to secure the bonnet in the open position. The bonnet safety catch is illustrated in Fig. 1-9.

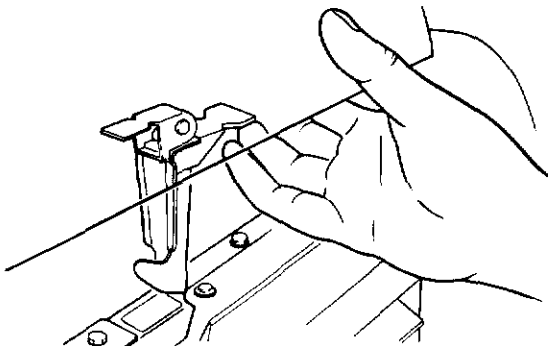

Figure 1-9 Bonnet safety catch

70. Accelerator pedal (Fig. 1-24 Item 23)

The accelerator pedal controls the engine speed via the accelerator cable. Depress the pedal to increase engine speed.

71. Foot brake pedal (Fig. 1-24 Item 24)

The foot brake pedal controls the application of the service brakes to all six wheels. Depress the pedal progressively to apply increased braking pressure.

72. Starter switch (Fig. 1-24 Item 25)

The starter switch is a four position switch, providing control over the ignition, glow plugs and starter motor. The switch is turned clockwise to activate the vehicle electrical system.

73. Main lighting switch (Fig. 1-24 Item 26)

The main lighting switch is a three position switch, providing control over the lighting as follows (see Fig. 1-10).

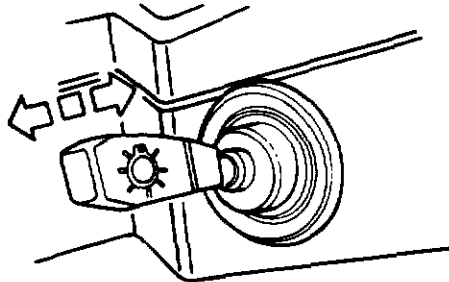

Figure 1-10 Main lighting switch

- a. With the switch pulled toward the driver, all lights will be off.
- b. With the switch in the centre position, the park lights will be illuminated.
- c. With the switch pushed away from the driver, both the main and park lights will be illuminated.

74. The main lighting switch will not function during blackout conditions.

75. Clutch pedal (Fig. 1-24 Item 27)

Depress the clutch pedal to disengage the clutch.

76. Cigar lighter (Fig. 1-24 Item 28)

Push the lighter in to operate. The lighter will automatically return to the normal position when ready for use.

77. Parking brake lever (Fig. 1-24 Item 29)

The parking brake is applied by pulling the lever up. To release the brake, pull the lever slightly up, depress the release button and push the lever down. Application of the parking brake will illuminate a warning light on the instrument panel.

78. Gear lever (Fig. 1-24 Item 30)

The gear lever is used to manually change the gear ratios in the transmission. The gear change pattern is illustrated in Fig. 1-11.

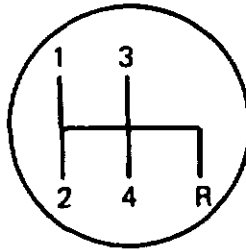

Figure 1-11 Gear change pattern

79. Transfer case shift lever (Fig. 1-24 Item 31)

The transfer case shift lever provides the manual selection of high or low gear ratios as required. The ratio shift pattern is illustrated in Fig. 1-12.

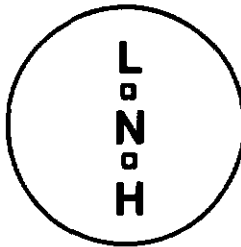

Figure 1-12 Transfer case shift pattern

80. Fuse box (Fig. 1-24 Item 32)

Removing the fuse box cover allows access to the fuses. The location of each fuse is provided by the decals as shown in Fig. 1-13.

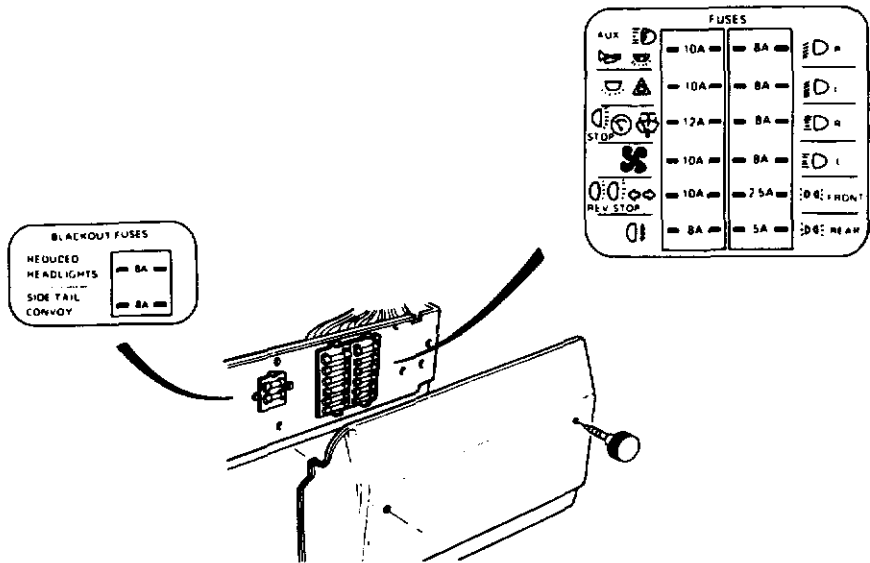

Figure 1-13 Fuses

81. The stop/start control motor is protected by a 10 amp fuse located under the bonnet to the side of the brake master cylinder.

82. Map reading light (Fig. 1-24 item 33)

The map reading light switch is located on the end of the light unit. The light can only be utilized when the ignition is on.

83. Cabin seating (Fig. 1-14)

The central cabin seat back can be tilted forward and utilized as a platform by the observer using the roof hatch, and the fore and aft movement can be adjusted as illustrated in Fig. 1-14.

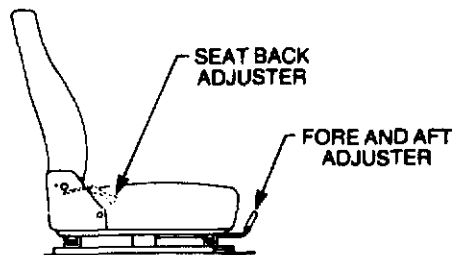

Figure 1-14 Seat adjustment

Body and Chassis Fittings

84. Vehicle body construction

The chassis frame is an all welded construction type, consisting of box section steel runners and crossmembers. The frame is hot dipped galvanized to prevent the formation of rust. One crossmember is detachable to simplify servicing. The cab consists of pressed aluminium and fibreglass panels that form the engine compartment bolted to a galvanized steel frame.

NOTE

The body, chassis and engine have certain common features with other variants to allow for variant transfer throughout the life of the fleet. It is not intended that this occur regularly but allow flexibility in fleet management should circumstances dictate.

85. Electronic repair module construction

The module consists of a welded galvabond tubular steel frame with a fibreglass outer skin bonded to the frame. The interior walls and ceiling are constructed from fibreglass and the floor is constructed from wood.

86. Stowage

A stowage bin is provided in each side of the rear body section, behind the rear wheels. These bins are lockable and the key is located in a canvas pocket secured to the right hand side of the seat box.

87. Rear window (Fig. 1-15)

A sliding window is fitted to the rear of the cab.

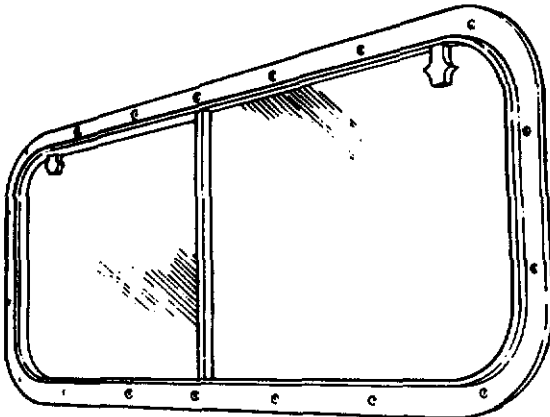

Figure 1-15 Rear window

88. Roof hatch (Fig. 1-16)

A roof hatch is fitted to the roof panel to provide an observation hatch.

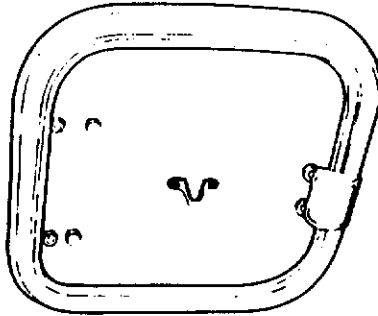

Figure 1-16 Roof hatch

89. Rear side windows (Fig. 1-17)

Rear side windows are fitted to the cabin to provide ventilation. They may be locked in either the open or closed position by an over-centre catch.

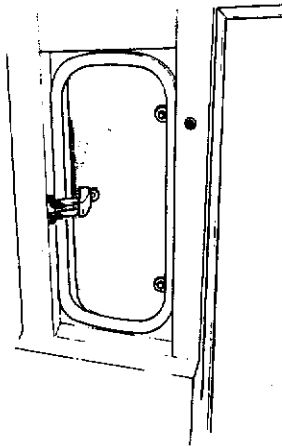

Figure 1-17 Rear side window

90. Jerrican stowage

Two jerricans can be stowed, in carriers, on the right hand side of the vehicle behind the cab.

91. Rifle clips and butt boxes

There are facilities to mount two rifles between the seats in the cabin and on either side of the module rear door opening.

92. Fire extinguishers

Two fire extinguishers are fitted to the vehicle. A 1.5 kg BCF is located on the rear bulkhead behind the cabin seats and a 3.0 kg BCF is located on the inside of the rear door of the module.

93. De-ditching tools

The de-ditching tools are mounted in brackets fitted to the bonnet. The tools comprise one axe, one shovel and one pick with handle.

94. Spare wheel stowage

The spare wheel is stowed under the vehicle behind the rear axle and is secured by a chain. The wheel is lowered from the stowed position by using the wheel brace to operate a winch drive (see Fig. 1-18) situated behind the left hand rear mudguard. The spare wheel is positively locked in the travelling position by a brake in the winch mechanism. When raising the spare wheel an additional resistance to movement of the wheelbrace, indicates the spare is correctly stowed. The spare wheel can be lowered by rotating the wheel brace in a counter clockwise direction.

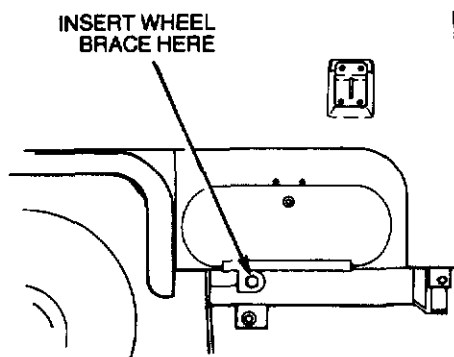

Figure 1-18 Spare wheel lowering

95. Electrical trailer connection sockets

A 12-pin NATO trailer connection socket is fitted to the rear of the left hand chassis rail. A supplementary, 7-pin, Utilux connection is fitted to the rear of the right hand chassis rail. Although this is wired in a conventional manner, it is not intended for use with trailers.

96. Towing pintle

A removable towing pintle is secured to the rear crossmember of the vehicle by four bolts, washers and nuts to allow for removal if necessary.

97. Seat belts

Inertia reel lap/sash seat belts are fitted to the outer cabin seats. The centre seat has a lap belt only fitted.

98. Rear vision mirrors

The external rear vision mirrors are hinged to fold back (inward) when knocked or bumped, thus reducing damage during cross country operations.

99. Battery box

Two batteries are housed in a box forward of the left hand rear mud-guard and are accessed through a lift up lid. A label detailing battery replacement procedures is affixed to the inside of the lid.

100. Vehicle nomenclature plate (Fig. 1-19)

The vehicle manufacturer's identification number is stamped on a plate that is riveted to the passenger's seat box. The identification number is also stamped on the right hand side of the chassis, forward of the spring mounting turret.

TRUCK ELECTRONIC REPAIR	
LIGHT MC2	
LIABILITY C/N	73220/01
MANUFACTURER	JRA LIMITED
MODEL No	LAND ROVER 110 6 x 6
CAPO No	N143896
DELIVERED	
MANUFACTURER'S V.I.N.	



Figure 1-19 Vehicle nomenclature plate

101. Servicing data plate (Fig. 1-20)

The vehicle servicing data plate is riveted to the passenger's seat box, adjacent to the vehicle nomenclature plate.

SERVICING DATA				
		HIGHWAY	CROSS COUNTRY	SAND
COLD TYRE PRESSURES (kPa)	FRONT	350	275	225
	REAR	350	275	225
LUBRICATION — NORMAL OR TROPICAL TEMPERATURES				
ENGINE	OMD 115	MASTER CYLS	OX (AJUST.) 8	
GEARBOX	OMD 115	MANUAL STG. BOX	OEP 220	
TRANSFER BOX	OMD 115	POWER STG. BOX	OX46 or OX47	
AXLES	OEP 220	LUBE. NIPPLES	XG274	
SWIVEL PIN H'SING	OEP 220	WINCH	OEP 220	
ELECTRICAL — 12 VOLT NEGATIVE TO EARTH SYSTEM				

Figure 1-20 Servicing data and tyre pressure plate

102. Shipping data plate (Fig. 1-21)

A shipping data plate is riveted to the passenger's seat base just below the servicing date plate.

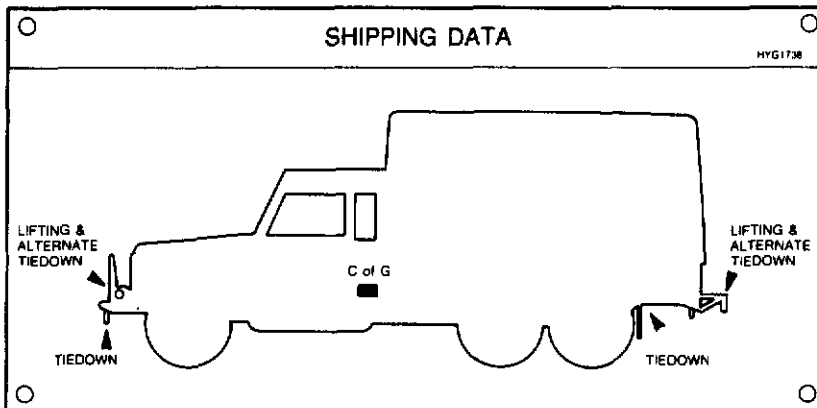

Figure 1-21 Shipping data plate

103. Towing and dyno test data plate (Fig. 1-22)

The towing and dyno test plate is riveted to the driver's seat box. See para. 234 for propeller shaft removal precautions.

TOWING AND DYNO TEST DATA	
FLAT AND LIFT TOWING — DISTANCE UNDER 200 KM	
·	SET GEARBOX AND TRANSFER CASE IN NEUTRAL.
·	SET TRANSFER BOX CONTROL SWITCH IN "ON-ROAD" POSITION.
·	ENSURE DIFF LOCK & 6WD WARNING LIGHTS ARE NOT ILLUMINATED.

FOR DISTANCE OVER 200 KM	
·	REMOVE PROPELLER SHAFTS AND REPEAT ABOVE
DYNO TEST ON FRONT AXLE	
·	REMOVE PROPELLER SHAFTS FROM BOTH REAR AXLES
·	SET TRANSFER BOX CONTROL SWITCH TO "CROSS COUNTRY"
·	ENSURE DIFF LOCK WARNING LIGHT IS ILLUMINATED
	HYG 2951

Figure 1-22 Towing and dyno test data plate

104. Jacking plate (Fig. 1-23)

A jacking plate is fitted to the stowage area lid as well as to the jack itself.

JACKING PROCEDURE	
	HYG 1764
<p>DUE TO THE FITMENT OF A TRANSMISSION HANDBRAKE TO THIS VEHICLE, THE JACKING PROCEDURE MUST BE FOLLOWED BEFORE JACKING ANY WHEEL CLEAR OF THE GROUND.</p>	
1.	APPLY HANDBRAKE.
2.	ENGAGE DIFFERENTIAL LOCK (WARNING LIGHT WILL ILLUMINATE).
3.	SELECT 1ST GEAR — LOW RANGE.
4.	CHOCK BOTH SIDES OF WHEEL FURTHEST FROM WHEEL BEING RAISED.
5.	SLACKEN WHEEL NUTS (5).
6.	FRONT WHEELS: POSITION JACK UNDER AXLE CASING IMMEDIATELY BELOW ROAD SPRING BETWEEN END FLANGE AND SUSPENSION BRACKET. REAR WHEELS: POSITION JACK UNDER AXLE CASING IMMEDIATELY BELOW ROAD SPRING NEAR DAMPER.
7.	REPLACE WHEEL AND TIGHTEN NUTS.
8.	LOWER VEHICLE.
9.	TORQUE NUTS: 100-115 Nm (75-85 lb. ft.).
10.	DISENGAGE DIFFERENTIAL LOCK BEFORE MOVING OFF.

Figure 1-23 Jacking procedure plate

105. Centre of gravity (C of G) designation plate

A "C of G" plate designating the longitudinal point of balance of the unladen vehicle is fitted to the left hand sill panel. See Fig. 1-3 for C of G dimensions.

106. Unit/formation signs

Four unit/formation sign holders are fitted to the vehicle. Two are riveted just below the headlights and the other two are riveted to brackets on the rear crossmember.

107. Bridge classification sign

Due to the size and weight of this vehicle, no bridge classification sign is fitted.

108. Camouflage net lashing points

Lashing points are provided on each side of the module for securing camouflage equipment. Lashing points are also incorporated on the module roof.

NOTE

These lashing points are not to be subjected to high tension loadings.

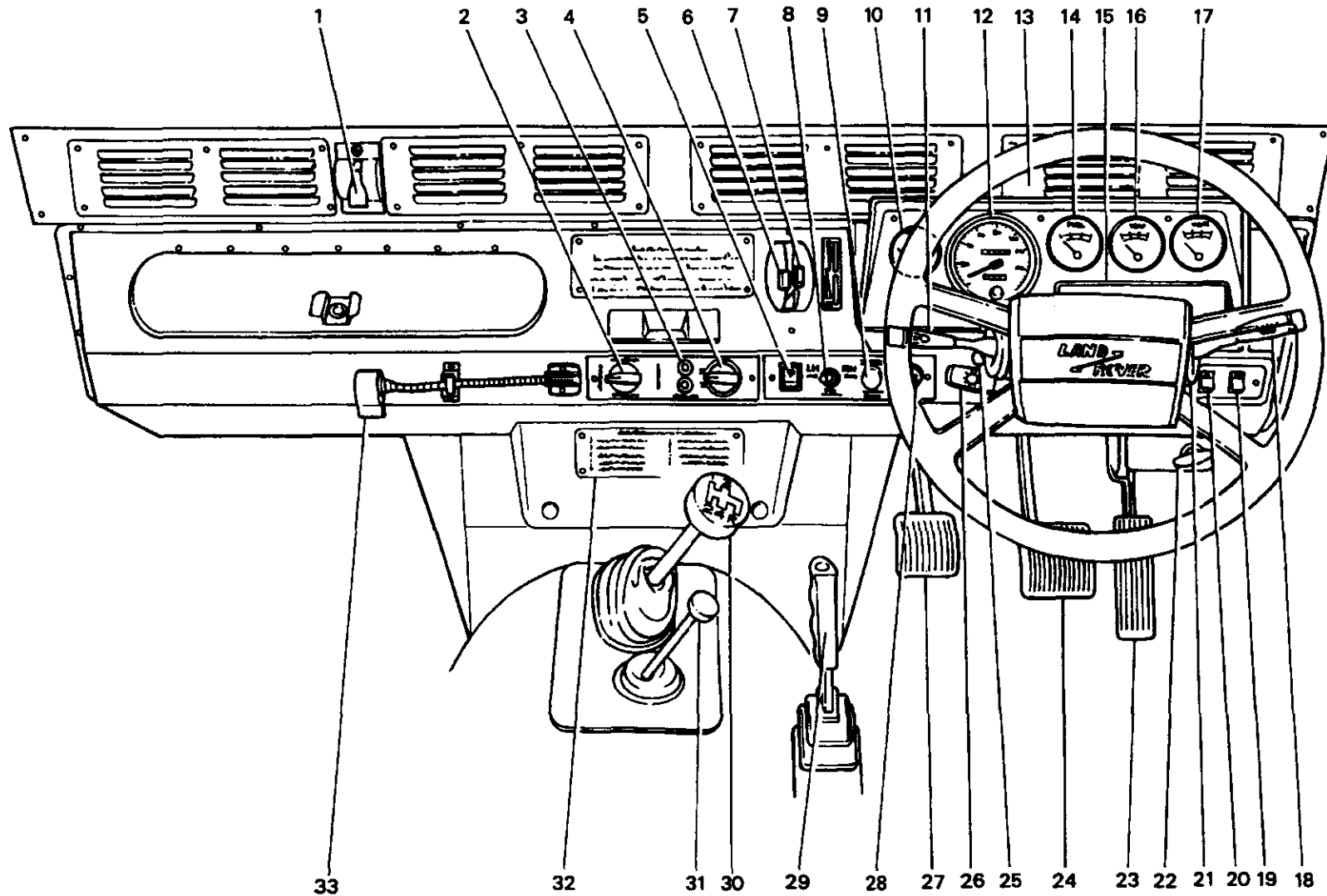

- | | | |
|-------------------------------|--|-------------------------------|
| 1. Ventilator control | 12. Speedometer | 23. Accelerator pedal |
| 2. Lighting control | 13. Ventilator control | 24. Brake pedal |
| 3. Auxiliary power | 14. Fuel gauge | 25. Starter switch |
| 4. Panel light dimmer control | 15. Warning light cluster | 26. Main lighting switch |
| 5. Heater fan control | 16. Temperature gauge | 27. Clutch pedal |
| 6. Air temperature control | 17. Voltmeter (12V) | 28. Cigar lighter |
| 7. Air distribution control | 18. Windscreen washer and wiper switch | 29. Parking brake lever |
| 8. Fuel switch | 19. Cab dome light switch | 30. Gear lever |
| 9. Transfer case control | 20. Hazard warning switch | 31. Transfer case shift lever |
| 10. Voltmeter (24V) | 21. Hand throttle | 32. Fuse box |
| 11. Combination switch | 22. Bonnet release | 33. Map reading light |

Figure 1-24 Instruments, electrical accessories and controls

CHAPTER 2

OPERATING INSTRUCTIONS

SECTION 1 — WARRANTY AND REPAIR

SECTION 2 — VEHICLE OPERATION

SECTION 1

WARRANTY AND REPAIR

Warranty provisions

201. The Contractor (JRA Limited) accepts responsibility for warranty in respect to the whole vehicle (except GFE items other than the mounting of such items) for a period of 12 months or 20 000 km, whichever occurs first from the time of issue of vehicle to user unit. Where vehicles are delivered to supply depots for extended storage, the depot becomes the user unit.

202. Where a vehicle is delivered into storage, provision is made for the warranty to be suspended for up to two years. Should the vehicle enter service during the two year period, then a pro-rata warranty applies in accordance with Table 2-1.

Table 2-1 Pro-rata warranty

Time of Withdrawal from Storage (measured from day of delivery into storage)	Period of Warranty after Withdrawal from Storage	
	Distance (km)	Time (mths)
(whichever expires first)		
First day of 1st month — last day of 3rd month	20 000	11
First day of 4th month — last day of 6th month	18 000	10
First day of 7th month — last day of 9th month	16 000	9
First day of 10th month — last day of 12th month	14 000	8
First day of 13th month — last day of 15th month	12 000	7
First day of 16th month — last day of 18th month	10 000	6
First day of 19th month — last day of 21st month	8 000	5
First day of 22nd month — last day of 24th month	6 000	4*
First day of 25th month — last day of 27th month	3 000	3*

***NOTE:** The warranty finally expires after twenty-seven (27) months irrespective of any outstanding distance or time pro-rata warranty.

Special provisions

203. The warranty shall not apply where failure arises from:

- a. Vehicle not being maintained in accordance with User Handbook or EMEI manuals.
- b. EMEI storage procedures not being effectively applied.
- c. Misuse or neglect.
- d. The fitting of non-genuine parts, and where it is mutually agreed as a contributing factor.

- e. The use of equipment not normally or reasonably associated with the operation of the supplies.
- f. Supplies that have been altered in form or function without consultation with and approval of the Contractor.
- g. Any part or parts of which the specification has been altered by the Commonwealth without the Contractor's approval.
- h. Any part or parts from which the identification marks or numbers have been altered or removed by the Commonwealth.
- i. Repairs which involved or resulted from either directly or indirectly the use of non-genuine parts.
- j. Incorrect tuning, adjustments or maintenance operations which are associated with periodic servicing requirements.
- k. Parts or equipment which have not been supplied by the Contractor or by a supplier approved by the Contractor and any problems which may arise, either directly or indirectly from the fitment of such equipment.
- l. The consequences of the supplies having been repaired by a non-approved repairer. For the purpose of this clause, approved repairer shall include Army vehicle maintenance personnel.

Application of warranty

204. The application of the warranty will be by repair or replacement of the defective component at no cost to the Commonwealth.

205. Provision is made for warranty repairs to be carried out by JRA Limited authorised Land Rover dealers and a list of such dealers is included in this publication.

206. However, if for reasons of distance, location etc., it is not practical to have the necessary repairs carried out by a JRA Limited authorised Land Rover dealer, then an Army tradesman is approved to carry out the repair. This procedure should be adopted in the case of emergency or essential repairs only (e.g. for safety, prevention of further damage or an operational requirement).

207. In such circumstances, JRA Limited will reimburse the Army for parts used at cost and labour at standard repair times and the prevailing Land Rover dealer warranty hourly labour rate.

208. The information required to be documented by the Army unit in such circumstances is:

- a. Identify the vehicle by chassis and or Army registration number.

- b. Date vehicle entered service (if known).
- c. Current odometer reading.
- d. Nature of failure (brief explanation).
- e. Nature of repair necessary.
- f. Parts replaced by designation and part number.
- g. Time taken or Standard Repair Time (SRT) and operation number (refer to EMEI VEH A 119-22).
- h. If parts were procured through a Land Rover dealer, then documentation identifying purchase and price paid.
- i. JRA Authority Number (if applicable).

209. The procedure for submitting a claim to JRA Limited to obtain reimbursement is defined in EMEI VEH A 119-22.

Prior consultation

210. Where a vehicle is presented to an authorised JRA Limited Land Rover dealer for warranty repairs, the Army need not be concerned as the dealer has adequate authority to deal with most situations and the necessary procedure to obtain authority in the case of major repairs.

211. In circumstances where the Army are themselves undertaking a warranty repair, this may proceed without authority provided the estimated total material and labour cost is less than \$500. If the cost is estimated to be in excess of \$500, then the appropriate JRA Limited State Office listed in Table 2-2 should be contacted for authority and guidance.

212. The person making the contact should have the following information available:

- a. Vehicle chassis and Army registration number.
- b. Date in service (if known).
- c. Current odometer reading.
- d. Knowledge of the problem encountered.

Continuance of warranty following a warranty repair

213. Any supplies corrected or furnished by way of replacement under warranty claim, whether it be an initial equipment supply or replacement part, will enjoy the balance of any existing warranty.

Warranty on replacement parts and MSI's

214. Except when fitted in the execution of a warranty repair,

replacement parts and MSI's enjoy the same warranty as the vehicle and in general terms as applicable the same special provisions apply (see para. 203).

Pre expiration warranty checks

215. Vehicles are to be inspected by RAEME Technical Support personnel prior to expiry date of the warranty. Refer EMEI VEH A 119-22.

Table 2-2 JRA State Offices

JRA State Offices	Telephone	Telex	Facsimile
N.S.W. Cnr. Heathcote Rd. and Church St., LIVERPOOL NSW 2170	(02) 600 1333	25375	(02) 602 1759
VIC. (TAS.) Level 1, Southgate 10 Jamieson St., CHELTENHAM VIC 3192	(03) 581 5600	—	(03) 581 5660
QLD. Cnr St Pauls Terr. and Brunswick St., FORTITUDE VALLEY QLD 4006	(07) 854 1599	42311	(07) 52 3776
S.A. (N.T.) 164 Fullerton Rd., DULWICH S.A. 5065	(08) 332 7799	—	(08) 364 0456
W.A. 6 Glassford Rd., KEWDALE W.A. 6105	(09) 353 1499	—	(09) 353 1498

List of agents

216. Table 2-3 details the Land Rover dealers throughout Australia and their repair level capability. This list was correct at the time of printing. A list of current Land Rover dealers is available from JRA State Offices.

Table 2-3 Land Rover dealers

Agent	Repair Level
Queensland (1 MD)	
Ayr General Engineering Co (077- 83 2393) 28 Queen Street Ayr QLD 4807	Unit
Brisbane (Newstead) Austral Motors (07-253 9427) 145 Breakfast Creek Road PO Box 199 Fortitude Valley Newstead QLD 4006	Base
Bundaberg Alan Powell Jaguar Rover (071- 72 9666) 26 Bourbong Street Bundaberg QLD 4670	Field
Burketown Nowland Engineering (011- 077- 45 5107 via exchange) Gregory Street Burketown QLD 4830	Field
Caloundra Pacific Jaguar Rover (071- 91 1344) 32 Bowman road Caloundra QLD 4551	Base
Cairns John Broadley Jaguar Rover (070- 31 3000) 94 McLeod Street Cairns QLD 4870	Base
Cooktown Peninsula Auto Services (070-69 5327) 10 Boundary Street Cooktown QLD 4871 Phil Witheridge (Prop.)	Field

Table 2-3 Land Rover dealers (cont'd)

Agent	Repair Level
Cunnamulla Casey-Gemac (074-55 1688) 25 John St Cunnamulla QLD 4490	Unit
Goondiwindi Jack Rose's Garage (076-71 1194) 4 Moffit Street Goondiwindi QLD 4390	Unit
Gympie Gympie Carworld (071- 82 2822) 109-113 River Road Gympie QLD 4570	Field
Ipswich Don Faulkner Motors Pty Ltd (07-281 2744) Cnr Warwick and Churchill roads Ipswich QLD 4305	Base
Mackay Roberts Motors (079- 57 2144) 85 Gordon Street Mackay QLD 4740	Base
Maryborough Jack Casey Motor Centre (071- 21 2545) 103 Lennox Street Maryborough QLD 4650	Base
Mount Isa Ian Brien Ford (077- 43 4622) 59 West Street Mount Isa QLD 4825	Base

Table 2-3 Land Rover dealers (cont'd)

Agent	Repair Level
Normanton Top Service Station (077- 45 1261 STD) (077- 40 7777 via exchange) Landsborough Street Normanton QLD 4890	Field
Southport Southport Motors (075- 32 1833) 187 Nerang Road Southport QLD 4215	Base
Stanthorpe McCosker Motors (076- 81 1202) 127 High Street Stanthorpe QLD 4380	Unit
Toowoomba Alan Flohr Jaguar Rover (076- 34 3233) Cnr James and Anzac Avenues Toowoomba QLD 4350	Base
Townsville Tony Ireland Townsville (077- 71 6855) 87 Charters Towers Road Townsville QLD 4810	Base
Weipa Weipa Mobil Service Centre (070- 69 7277) Boundary Road Weipa QLD 4874	Field
Winton Winton Motors (074- 57 1477) 21 Oondooroo Street Winton QLD 4735	Unit

Table 2-3 Land Rover dealers (cont'd)

Agent	Repair Level
New South Wales (2 MD)	
Albury Albury Motors Pty Ltd (060- 21 2188) 478 Olive Street Albury NSW 2640	Base
Annangrove John E Davis Motor Works (02-679 1179) 225 Annangrove Road Annangrove NSW 2156	Field
Arncliffe Purnell Motors (02- 59 0241) 139 Princes Highway Arncliffe NSW 2205	Base
Artarmon New Rowley Motors (02- 436 0857-0987) 393 Pacific Highway Artarmon NSW 2064	Base
Bathurst Bathurst Prestige Cars (063- 31 3422) 124-132 Russell Street Bathurst NSW 2795	Unit
Bombala Lomas' Garage (064- 58 3311) 80-86 Maybe Street Bombala NSW 2553	Field
Bowral Reynolds Motors Bowral Pty Ltd (048- 61 2444) 252 Bong Bong Street Bowral NSW 2576	Unit

Table 2-3 Land Rover dealers (cont'd)

Agent	Repair Level
Broken Hill Williams Motors (080- 88 7868) 80-82 Oxide Street Broken Hill NSW 2880	Field
Carlton Lindsay Johnstone (02- 546 3211) 57 Planthurst Road Carlton NSW 2218	Base
Casino Capitol Car Sales (066- 62 1477) Centre Street Casino NSW 2470	Unit
Coffs Harbour Autocare (066- 52 1422) 115 High Street Coffs Harbour NSW 2450	Field
Dorrigo Doust and Fitzgerald (066-57 2116) 14-16 Cudgery Street Dorrigo NSW 2453	Field
Dubbo Dubbo City Jaguar (068- 82 1511) 3-5 Bourke Street Dubbo North NSW 2830	Unit
Dungog Modern Motors (049- 92 1486) 282 Dowling Street Dungog NSW 2420	Field
Gloucester Gloucester machinery Co P/L (065-58 1510) 19 Denison Street Gloucester NSW 2422	Field

Table 2-3 Land Rover dealers (cont'd)

Agent	Repair Level
Homebush Asquith and Johnstone Pty Ltd (02- 764 1777) 145 Parramatta Road Homebush NSW 2140	Base
Hurstville Arthur Garthon Motors (02-588 5000) 71A Forest Road Hurstville NSW 2220	Base
Inverell T & T Machinery Pty Ltd (067-22 2936) 79-85 Ring Street Inverell NSW 2360	Field
Lismore John Chant Car Sales (066-21 2601) Cnr Balina and Brewster Streets Lismore NSW 2480	Field
Maitland George White Motors (049-33 5233) 317-323 High Street Maitland NSW 2320	Base
Moorebank Wrendco Automotive Repairs (02- 600 6537) 8 Seton Road Moorebank NSW 2170	Base
Nowra Tory Classic Cars (044- 21 0922) Kingshorn Street Nowra NSW 2541	Field
Singleton R. and E. Teasdale Pty Ltd (065- 72 1655) 64 George Street Singleton NSW 2330	Field

Table 2-3 Land Rover dealers (cont'd)

Agent	Repair Level
Sydney (City) City Automobiles (02- 33 0678) 123-129 William Street Sydney NSW 2000	Base
Taree Manning Valley Motors (065- 52 1088) 8-16 Victoria Street Taree NSW 2430	Base
Tamworth Tamworth Prestige (067- 65 3000) Cnr In and Hercules Streets Tamworth NSW 2340	Base
Toronto Triggs Motors (049- 59 2122) 36-44 Victory Parade Toronto NSW 2283	Base
Wagga Wagga Jupiter Motors Pty Ltd (069- 21 6555) 20 Edward Street Wagga Wagga NSW 2650	Field
Wauchope Wauchope Motors (065- 85 3766) 85 High Street Wauchope NSW 2446	Field
Wollongong Compass Car Centre (042- 29 8433) Princes Highway North Wollongong NSW 2500	Base

Table 2-3 Land Rover dealers (cont'd)

Agent	Repair Level
Victoria (3 MD)	
Bairnsdale J J Dwyer Garage (051- 52 3094) 46-56 Nicholson Street Bairnsdale VIC 3141	Base
Ballarat Gordon Motors Pty Ltd (053- 39 5022) 1041-1043 Howitt Street Wendouree VIC 3355	Base
Brighton Lane Jaguar Rover (03- 557 2875) 771 Nepean Highway Brighton VIC 3187	Base
Corryong Mildren and Coysh Pty Ltd (060- 76 1151) White Street Corryong VIC 3707	Field
Frankston Stewart Webster (03- 781 2022) 130 Dandenong Road Frankston VIC 3199	Base
Geelong Peck and Stokes Motors (052- 21 2111) 31-37 Gordon Avenue Geelong VIC 3220	Unit
Malvern ULR Sales and Service P/L (03- 822 0211) 1339 High Street Malvern VIC 3144	Base

Table 2-3 Land Rover dealers (cont'd)

Agent	Repair Level
Mansfield Berry and O'Halloran (057- 75 2375) 125 High Street Mansfield VIC 3722	Field
Mildura Syd Mills Motors (050- 23 0261) 19-29 Orange Avenue Mildura VIC 3500	Field
Morwell Massaro Motors (051- 34 1422) 497 Princes Highway Morwell VIC 3840	Field
Nunawading Whitehorse Motors Pty Ltd (03- 878 6677) 296 Whitehorse Road Nunawading VIC 3131	Base
Shepparton McPherson Motors (058-21 9400) 69 Benalla Road Shepparton VIC 3630	Field
South Yarra Kellow-Falkiner Motors (03- 266 2501) 93 Commercial Road South Yarra VIC 3141	Base
Wendouree Gordon Motors (Ballarat) P/L (053-38 1335) 1041-1043 Howitt Street Wendouree VIC 3355	Field

Table 2-3 Land Rover dealers (cont'd)

Agent	Repair Level
South Australia (4 MD)	
Bordertown Inglis Motors (087- 52 1577) 90 South Terrace Road Bordertown SA 5268	Field
Kingscote Nepean Motors Ltd (084- 82 2162) Kingscote Terrace Kingscote SA 5223	Unit
Millicent Mac Ford (087- 33 2022) 44 Mount Gambier Road Millicent SA 5280	Base
Port Lincoln H V Motors (086- 82 1600) 80 Mortlock Terrace Port Lincoln SA 5606	Unit
Walkerville Prestige Car Sales (08- 269 2922) 130-134 North East Road Walkerville SA 5081	Base
Western Australia (5 MD)	
Broome BP Shinju Motors (091-92 1250) Walcott Street Broome WA 6725	Field
Bunbury Wallace Motors Pty Ltd (097- 21 4588) 72 Spencer Street Bunbury WA 6230	Base

Table 2-3 Land Rover dealers (cont'd)

Agent	Repair Level
Carnarvon Dellbar Motors (099- 41 1397) 60 Robinson Street Carnarvon WA 6701	Field
Derby Kimwest Motors (091- 91 1647) 44 Clarendon Street Derby WA 6728	Field
Esperance Ratten and Slater (090- 71 0100) Cnr Norseman and Sheldon Road Esperance WA 6450	Field
Katanning P. L. Bolto and Co. (098- 21 1566) 71 Clive Street Katanning WA 6317	Field
Kununurra Norwest Diesel Service (091- 68 1195) Lot 219 Bloodwood Drive Kununurra WA 6743	Field
Manjimup Manjimup All Wheel Drive (097- 71 1535) Franklin Street Manjimup WA 6258	Field
Osborne park Alf Barbagallo (09-444 5999) 354 Scarborough Beach Road Osborne Park WA 6017	Field
South Hedland N and L Mechanical (091- 72 2623) Lot 3780 Carlindie Way, Wedgefield South Hedland WA 6722	Field

Table 2-3 Land Rover dealers (cont'd)

Agent	Repair Level
Wyndham Branco BP Motors (091- 61 1305) Great Northern Highway Wyndham WA 6740	Unit
Tasmania (6 MD)	
Hobart Terry Hickey Autos Pty Ltd (002- 34 9122) 167-171 Argyle Street Hobart TAS 7000	Base
Launceston Launceston Rover/Peugeot (003- 31 6633) Cnr. Wellington and Frederick Streets Launceston TAS 7250	Base
Northern Territory (7 MD)	
Alice Springs Sutton Motors (089- 52 1334) 13 Smith Street Alice Springs NT 0870	Field
Darwin Port Darwin Motors Pty Ltd (089- 81 9444) 15 Stuart Highway Darwin NT 0800	Base
Katherine Katherine Toyota (089- 72 1788) 1 Katherine Terrace Katherine NT 0850	Unit
Australian Capital Territory	
National Capital Motors (062-51 2600) Josephson Street Belconnen ACT 2617	Base

SECTION 2

VEHICLE OPERATION

217. General

Proper operation determines the service life and operating economy of the vehicle. This includes, careful driving, normal road speeds, reasonable rates of acceleration and braking and changing gears in a manner to avoid shock loading and labouring.

218. Before starting

Carry out a first parade service as detailed in Chapter 3 Section 1.

219. Before starting the engine

Ensure that the parking brake is applied. Depress the clutch pedal fully to disengage the clutch then move the gear lever to neutral.

220. Starting the engine

NOTE

The glow plugs need only be used to start the engine when the vehicle is operating continually in low ambient temperatures (below 5°C), and then for no longer than five seconds.

Depress the accelerator pedal approximately half way and hold the pedal in this position while turning the ignition switch clockwise to start the engine. As the switch is turned to the first position (see Fig. 2-1), the oil pressure, battery charge and parking brake warning lights will illuminate. In the next switch position the glow plug light illuminates, but do not hold the switch in this position unless cold operating conditions are experienced. Turn the switch fully to engage the starter motor, then release the switch and return the accelerator pedal to the idle position once the engine has started. All warning lights except the parking brake light should now be extinguished.

NOTE

Do not operate the starter motor continuously for longer than ten seconds without a pause.

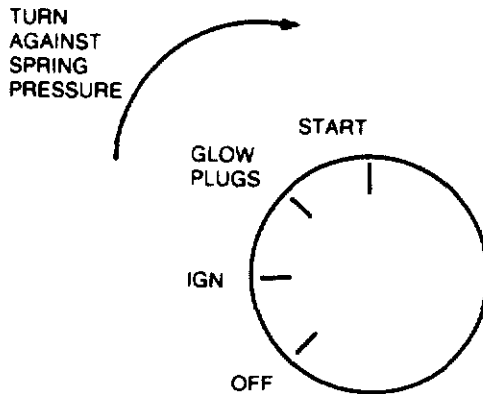

Figure 2-1 Starter switch positions

221. Moving the vehicle

- a. With the engine operating, disengage the clutch by pushing the pedal to the floor. Select high ratio or low ratio on the transfer case shift lever, depending on the vehicle load and terrain.

NOTE

Changing from high to low or low to high ratio should only be attempted when the vehicle is stationary. Should difficulty be encountered when engaging high or low ratio, do not force the lever. With the engine running, engage a gear with the main gear lever and release the clutch momentarily, then return the main gear lever to neutral and try the transfer case shift lever again.

- b. Select first gear on the gear lever then release the parking brake. If the parking brake warning light does not extinguish, do not attempt to move the vehicle.

- c. Engage the clutch smoothly by releasing the clutch pedal and simultaneously depressing the accelerator pedal the amount necessary for the engine to move the load.

NOTE

Never allow the foot to RIDE the clutch pedal with the clutch engaged. This causes premature clutch wear.

- d. As the vehicle gains speed, continue changing gear until cruising speed is achieved and the transmission is in the highest gear possible without labouring the engine.

Good driving habits

222. Engine temperature

Allow the engine to reach normal operating temperature before engaging in high speeds or hauling heavy loads.

WARNING

Should the engine become overheated, park the vehicle in a safe working area and allow the engine to cool before attempting repairs to, or refilling of, the cooling system.

223. Instruments

Glance at the instruments frequently. If a fault is indicated, assess the corrective action required and stop the vehicle as necessary.

224. Clutch

To avoid damage, engage the clutch with a smooth action. Do not RIDE the clutch.

225. Gear changing

Ensure that the correct gear is selected for the terrain, vehicle load and speed.

226. Braking

Avoid sudden stops. When stopping on slippery surfaces, smoothly apply and release the brakes alternately, to prevent skidding. When slowing to a halt, leave the clutch engaged as long as possible to utilize the engine braking effect. Before descending steep slopes, select first gear, low ratio with the differential locked to provide maximum engine braking.

227. Stopping the engine

Allow the engine to return to the normal idle speed before turning the ignition off.

228. Parking

Use the parking brake when parking the vehicle. Check frequently to ensure that the brake is adjusted to lock and hold the vehicle when parked. Do not use the parking brake when the vehicle is in motion, except in an emergency. When parking on an incline, leave the vehicle in gear.

229. Fording

The maximum advisable fording depth is 500 mm. When fording is to be undertaken, ensure that the flywheel housing drain plug is securely fitted (see Fig. 2-2). If deep water is anticipated, loosen the fanbelt to prevent damage to the fan or radiator, and saturation of the electrical system. Avoid excessive speed.

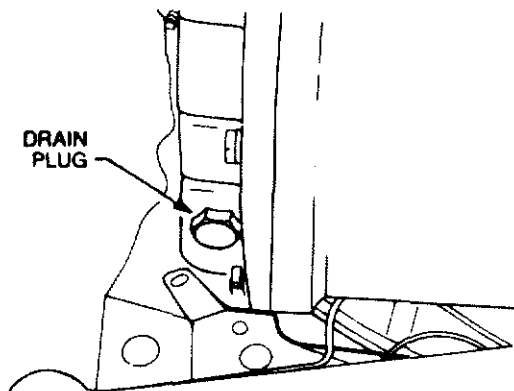

Figure 2-2 Flywheel housing drain

230. Once the crossing has been accomplished, drain the flywheel housing and tighten the fanbelt. Ensure that the brakes are dry and fully effective before proceeding.

NOTE

After fording, check the oil in the engine, transmission, transfer case and swivel pin housing for signs of water contamination. Change contaminated oils as soon as possible.

231. Cross country driving

WARNING

Because of the excellent rough terrain characteristics of this vehicle, drivers are cautioned to maintain a safe speed for the conditions encountered, **especially when towing a trailer or utilizing tyre chains.**

NOTE

The mobility of this vehicle is greatly enhanced if correct tyre pressures are maintained, and in extreme conditions, tyre chains are used.

The transfer case differential lock should be utilized for cross country driving, ie. off formed roads and tracks. When activated, the differential lock warning light will illuminate indicating that the dog-clutch in the transfer case is fully engaged. Although the differential lock can be engaged while the vehicle is moving, no power should be applied to the transmission during this operation.

NOTE

Under some conditions, a slight delay may be experienced before the warning light illuminates. This is due to the time required for the dog-clutch to align with its mating splines and become fully engaged.

232. On reaching normal road conditions, the differential lock must be disengaged.

NOTE

Under some conditions, a slight delay may be experienced before the warning light extinguishes after the switch is pushed in. If the warning light does not extinguish, this indicates that the dog-clutch is not fully disengaged. This is usually due to transmission wind-up which jams the dog-clutch. If the warning light does not extinguish within 100 metres of the switch being pushed in, the vehicle should be stopped and reversed a few metres to unwind the transmission. The warning light should now extinguish. **If not, do not continue as serious damage may occur.**

Changing a wheel

233. To replace a flat tyre with the spare wheel, proceed as follows:

- a. Remove the hydraulic jack, handle and jack base plate, from the stowage bin.
- b. Engage the differential lock and check that the differential lock warning light illuminates.

NOTE

If the vehicle has been stationary prior to changing the wheel, the differential lock may not engage when selected. In this case, it will be necessary to start the engine, engage a gear and release the clutch sufficiently to allow slight movement of the gears, until the warning light is illuminated. Switch off the engine.

- c. Ensure that the parking brake is applied and that the wheels are chocked.

WARNING

The parking brake acts on the transmission, not the rear wheels. The differential lock must be engaged and the wheels chocked to enable the vehicle to be raised safely.

- d. Engage first gear in the transmission and low range in the transfer case.
- e. Position the jack under the vehicle as follows:
 - (1) Front wheel. Position the jack so that when raised, it will engage with the front axle casing immediately below the coil spring, where it will locate between the flange at the end of the axle casing and the large bracket to which the front suspension members are mounted (see Fig. 2-3).

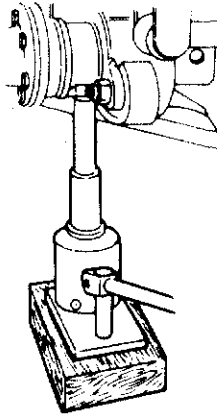

Figure 2-3 Jack position — front wheels

- (2) Rear wheel. Position the jack so that when raised, it will contact the axle tube between the spring and the shock absorber bracket (see Fig. 2-4).

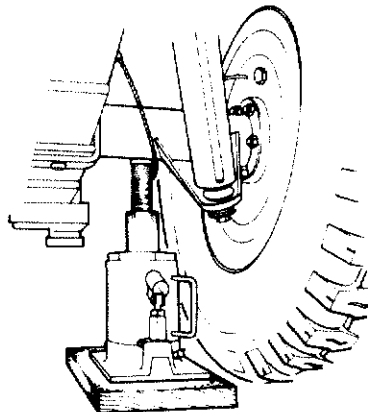

Figure 2-4 Jack position — rear wheels

- f. Before raising the vehicle, lower the spare wheel to the ground and remove it from under the vehicle, then using the wheel brace, initially slacken the nuts on the wheel to be removed.
- g. Jack up the appropriate corner of the vehicle. When the wheel is clear of the ground, remove the wheel nuts and lift off the wheel.
- h. Ensure that the wheel nuts and studs are clean then fit the spare wheel and secure with the wheel nuts. Tighten the wheel nuts.
- i. Lower the vehicle to the ground and torque the wheel nuts to 100-115 Nm (75-85 lb.ft) in the correct sequence (diagonally opposite). Use hand pressure only. Do not use foot pressure or extension tubes as this could overstress the wheel studs.
- j. Remove the jack and the wheel chocks then disengage the differential lock.

Towing the vehicle

234. The following precautions must be taken before this vehicle is towed:

WARNING

When using rear lift recovery, extreme caution must be observed.

- a. Set the transmission and transfer case to neutral.
- b. Set the transfer case control switch to the on-road position.
- c. Ensure that the differential lock warning light is extinguished. If the warning light fails to extinguish, both the front and rear propeller shafts are to be removed.
- d. When the front propeller shaft is to be removed, the flange mounting bolts must be secured with nuts or wire to prevent damage to the transmission casing.
- e. Welded to the bullbar and the rear crossmember are two towing eyes which are used as fixed mounting points to allow for the attachment of an A frame to facilitate vehicle recovery.

Battery replacement — 24 volt

235. To replace the batteries, proceed as follows:

- a. Stop the engine and ensure that the parking brake is applied.
- b. Slide the battery box out from the chassis.
- c. Remove the nuts and washers securing the lid to the battery box, and remove the lid.
- d. Remove the bridging cable which interconnects the batteries.
- e. Disconnect the negative and positive terminals respectively. Insulate each terminal as it is disconnected to prevent possible sparking.
- f. Remove the battery retaining frame, then remove the batteries.
- g. Install the new batteries and secure in position with the retaining frame.
- h. Connect the positive and negative terminals respectively, then connect the battery bridging cable between the remaining positive and negative terminals.
- i. Position the lid on the battery box and secure in position with the washers and nuts.
- j. Slide the battery box towards the chassis and lock the sliding frame in position.

CHAPTER 3

OPERATOR SERVICING

SECTION 1 — SERVICING

SECTION 2 — LUBRICATION

SECTION 1

SERVICING

First parade servicing

301. Before moving off with a loaded or unloaded vehicle, carry out the inspections, checks and tests as laid down in this section. Inspect for damage, security and serviceability.

302. Check the wheels and tyres for the following:

- a. Loose wheel nuts.
- b. Correct tyre pressure (see page 78).
- c. Cuts, weak spots, uneven wear, exposed cords, or clogged tyres.

303. Check the following fittings:

- a. All cabin and body fittings.
- b. Spare wheel.
- c. Stowage space, doors and lids.
- d. Windscreen, driving mirrors, door windows, hinges, catches and latches for security.
- e. All light lenses, driving mirrors and windscreens and clean as necessary.
- f. Tow hook, coupling and security.

304. Check the stowed items as follows:

- a. Completeness of equipment and correct stowage.
- b. For loose items in cabin or rear section.
- c. De-ditching tools.
- d. Fire extinguishers, fully charged and correctly stowed.

305. Check the fuel, lubricants and coolant as follows:

- a. Fuel level in tank. Replenish as necessary.
- b. Check jerrican and refill if necessary.
- c. Engine oil level using dipstick. Top-up as necessary.
- d. Coolant level in radiator expansion tank. Top-up if necessary.
- e. Water can in stowage. Top-up if necessary.
- f. For fuel, lubricant and coolant leaks. Examine major assemblies and the ground below the vehicle for evidence.

Start the vehicle

306. Start the vehicle as detailed in Chapter 2 Section 2 and check the following:

- | | | |
|----|---------------------------|--|
| a. | Voltmeter | Any irregular readings indicates battery or charging system requires checking. |
| b. | Horn | Check operation of the horn. |
| c. | Lights | Check operation of all lights. |
| d. | Windshield wipers/washers | Check operation. Add water, if needed. |
| e. | Parking brake | Check release, holding ability and application. |
| f. | Clutch pedal | Check for free travel. |
| g. | Seat adjustment | Ensure that seat is correctly adjusted. |

Electrical

307. Check the following:

- | | | |
|----|---------|---|
| a. | Battery | Check electrolyte level — fill to 10 mm above plates. Check that the terminals are clean and tight. |
| b. | Lights | Switch off all lights not required. |

Moving off and running

308. Check the following:

- Load — make a final check of the security of load and lashings, if applicable.
- Moving off — Release the parking brake. DO NOT move off if the parking brake warning light remains illuminated. Check correct operation of steering and brakes.
- Keep a running check on all instruments.
- Check the fuel level, coolant temperature, warning lights, charging rate and speedometer at intervals.

Halts on the march

309. At halts on the march check that:

- The cargo and lashings are secure, if applicable.
- No tyre is soft, punctured or overheated.
- Wheel hubs or brake drums are not overheated.
- There are no oil, fuel or coolant leaks.

310. At halts or after approximately four hours running:

- a. Check tyre pressures. If low, inflate. (If high, check later when tyres are cold, before deflating).
- b. Ensure that all wheel nuts are secure.
- c. Test all lights (especially if there is a possibility that they will be required).
- d. Check generally for loose bolts or fittings. Tighten as necessary.
- e. Ensure security of stowed items.
- f. Inspect for security and correct operation any parts on which recent repairs or adjustments have been carried out.

Last parade servicing

311. Carry out the following:

- a. Clean the vehicle.
- b. Carry out "halts on the march" servicing.
- c. Draw fuel and lubricants, as required and top-up fuel tanks, engine oil and radiator expansion tank coolant. If operating under very dusty conditions, the air cleaner should be removed and cleaned.
- d. If vehicle has been subjected to deep water crossings during daily exercise, the oil in the swivel pin housings, front, intermediate and rear axles, transmission and transfer case, should be checked for signs of water contamination. If any traces of water are found, the oil should be drained and replenished with correct type as soon as possible.
- e. Check radiator core for insects, mud, etc., clean as required with compressed air or water.
- f. Complete documentation.
- g. Close the doors and windows.

Opening bonnet for servicing access

312. To open the bonnet, proceed as follows:

- a. Pull the bonnet release handle.
- b. Release the safety catch at the front of the bonnet.
- c. Lift the bonnet up and pull the support stay forward.

WARNING

Ensure that the bonnet support stay is properly locked before releasing the bonnet.

313. To close the bonnet, proceed as follows:

- a. Hold the bonnet open and push the support stay back.
- b. Gently lower the bonnet then push the bonnet down firmly to lock in position. Do not allow the bonnet to drop from the open position.

Radiator coolant

314. Normal cooling system replenishment is via the expansion tank. However, in the event of excessive coolant loss or drainage, the following radiator filling procedure is to be adopted:

- a. Remove the expansion tank pressure cap and move the heater controls to the highest temperature position.
- b. Remove the brass filler plug from the thermostat housing (see Fig. 3-1).
- c. Using coolant with a mixture concentration of 5% Alfloc 2001, top-up the system through the filler hole, then replace the plug.
- d. With the pressure cap removed, run the engine for a minimum of two minutes.
- e. Stop the engine and remove the plug from the thermostat housing. Top-up as required, then install and tighten the plug securely.
- f. Fill the expansion tank to the correct level and install the cap.
- g. Run the engine and check for leaks.

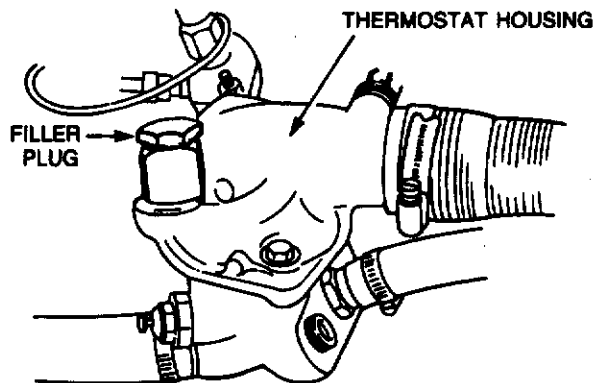

Figure 3-1 Thermostat housing

Bleeding the fuel system

315. To bleed the fuel system, proceed as follows:

- a. Loosen the screw cap on the transfer pump and operate the primer.
- b. Loosen the overflow valve on the fuel filter adapter (see Fig. 3-2) and continue operating the primer until a solid stream of fuel flows from the valve.
- c. Tighten the overflow valve and continue operating the primer. Loosen the air bleed screw on the fuel injection pump and continue operating the primer until a solid stream of fuel flows from the air bleed screw. Tighten the air bleed screw.
- d. Secure the primer screw cap and start the engine. Ensure that the engine runs smoothly.

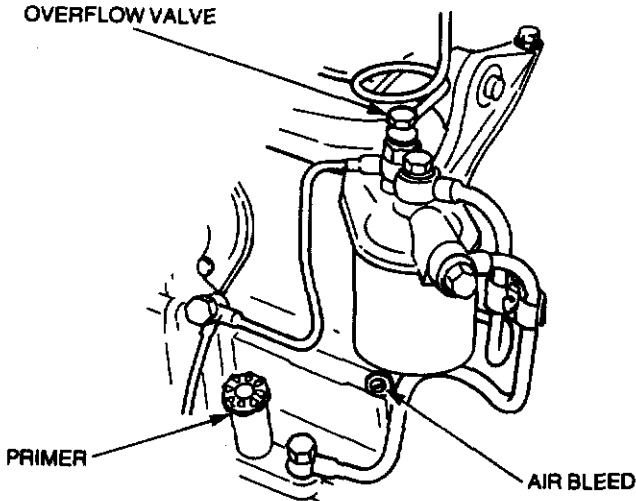

Figure 3-2 Bleeding the fuel system

316. Periodical maintenance

- a. To ensure that the vehicle is correctly maintained and prepared for operational tasks, it is necessary to carry out regular maintenance.
- b. Daily and Fortnightly Servicing in accordance with Tables 3-1 and 3-2 is to be carried out by operators and is the responsibility of owner units.
- c. Initial service should be carried out after the vehicle has

been in service for a period of three months, or having travelled 1600 km, whichever occurs first. The service is the responsibility of JRA Limited and will be carried out by arrangement with any Land Rover franchised Dealer at no charge to the Army, except for the cost of replacement lubricants and filters. Alternatively this service can be carried out by an Army tradesman in accordance with Table 3-3, should it not be convenient for the vehicle to be returned to the authorised Land Rover Dealer at that time.

- d. Minor and Major Servicing is to be carried out by RAEME with assistance from operators working under RAEME supervision in accordance with Tables 3-4 and 3-5. The unit is responsible for ensuring that the vehicle is serviced at the following intervals.
- (1) **Minor Service.** This is to be carried out every six months or 10 000 km of operation, whichever occurs first.
 - (2) **Major Service.** This is to be carried out every twelve months or 20 000 km of operation, whichever occurs first.

Special requirements

317. During the early life of a vehicle the working parts settle down, with the result that various clearances and adjustments need to be corrected. Operators should report problems for rectification at the earliest opportunity.

318. The Initial Service includes a warranty inspection which must be reported to Land Rover Australia in accordance with EMEI VEHICLE A 119-22.

319. Vehicles are to be inspected by RAEME Technical Support personnel prior to expiry date of the warranty. Refer EMEI VEH A 119-22.

Table 3-1 Daily tasks

The following operations are to be performed by the driver:

1. Check engine oil level, top-up if necessary.
2. Check coolant level, top-up if necessary.
3. Check power steering reservoir, top-up if necessary.
4. Check tyres and wheels. Inflate tyres if necessary, inspect wheel nuts for evidence of looseness.

Table 3-1 Daily tasks (cont'd)

5. Check for fuel, oil and coolant leaks.
6. Check fuel supply and operation of fuel gauge.
7. Check voltmeter readings. With ignition switch on and engine off, reading indicates battery condition. With engine running, reading indicates condition of charging system.
8. Check operation of horn.
9. Check all lights for correct operation and report any defects.
10. Check operation of footbrake, parking brake and clutch.
11. Check coolant temperature gauge reading.
12. Check operation of windscreen wipers and washers, top-up washer reservoir if required.
13. Check air cleaner restriction gauge reading. If locked in "red" position, the air cleaner elements must be changed. Under dusty conditions, remove and clean elements.
14. Check seats and seat belts for operation and security.
15. Check driving mirrors, door windows, catches and latches.

Table 3-2 Fortnightly tasks

The following operations are to be performed by the driver:

1. Check condition and tension of fanbelts. Approx. 10-15 mm deflection on longest span using moderate thumb pressure for both alternator belts .
2. Check battery electrolyte levels (10 mm above plates), top-up if necessary, examine terminals for cleanliness and security. Check for leaks and security, clean outside of batteries if required.
3. Check radiator external condition for restriction, clean if required.
4. If operating in dusty conditions, remove air cleaner elements and clean.
5. Check operation of hand throttle and stop control.
6. Check operation of differential lock control.
7. Check operation of transfer case control.

Table 3-2 Fortnightly tasks (cont'd)

8. Check condition of wheel rims, tyres and valve stems.
9. Check wheel nuts are torqued correctly.
10. Check operation and security of spare wheel carrier.
11. Check security of fuel tanks and lines.
12. Check fuel, oil and coolant systems for leaks.
13. Drain water from sedimenters.

Table 3-3 Initial servicing

The following operations are to be performed by the driver under supervision:

1. Start and warm up the engine.
2. Stop the engine, drain engine oil and refill.
3. Remove and replace oil filters.
4. Drain and refill transmission.
5. Drain and refill transfer case.
6. Drain and refill front axle.
7. Drain and refill intermediate axle.
8. Drain and refill rear axle.
9. Drain and refill swivel pin housings.
10. Lubricate propeller shafts and universal joints.
11. Lubricate pintle hook.
12. Check battery electrolyte levels (10 mm above plates) and security of terminals.
13. Check all fuel and oil lines and unions for leaks.
14. Retorque all wheel nuts to correct specifications.
15. Check tyres and wheels, inflate if necessary. Inspect rims for damage.
16. Check operation of all lights and gauges.
17. Check for loose electrical connections.

Table 3-3 Initial servicing (cont'd)

18. Check operation of foot brake, parking brake and clutch.
19. Check exhaust systems for leaks, damage and security.
20. Tighten all module-to-chassis mounting bolts.
21. Tighten all step and platform mounting bolts. Check the function of latches and catches.
22. Tighten and check all rear door mount latches. Lubricate and check the function of the catches.
23. Check operation of module electrical components, including air conditioning, which requires a 240 volt supply to operate.
24. Check function of all doors, seals and vents.

The following operations are to be performed by a Qualified Vehicle Mechanic:

25. Retorque inlet and exhaust manifolds.
26. Check and adjust fanbelt tension. Retorque alternator mounting bolts.
27. Check torque of radiator mounting bolts, tighten as required.
28. Tighten all propeller shaft coupling drive bolts.
29. Replace primary fuel filter and bleed system.
30. Road Test. Carry out a road test on steering and brake system. Note all faults and rectify as necessary.

Table 3-4 Minor servicing

The following operations are to be performed by the driver under supervision:

1. Start and warm up engine.
2. Stop engine, drain engine oil and refill.
3. Remove and replace oil filters.
4. Check condition of engine mountings.
5. Check engine hand throttle and stop control for connections and operation.
6. Check all lights and gauges for correct operation, report defects.

Table 3-4 Minor servicing (cont'd)

7. Check condition of radiator shroud and fins. Clean fins as necessary.
8. Retorque radiator hose connections.
9. Check operation of footbrake, parking brake and clutch.
10. Check operation of windscreen wipers and washers.
11. Check condition of windscreen wiper blades.
12. Check battery electrolyte levels (10 mm above plates) and security of terminals. Check batteries for cleanliness and security.
13. Check for oil, fuel and coolant leaks. Report any defects.
14. Check tyres and wheels, inflate if necessary. Inspect rims for damage.
15. Drain fuel sedimenters.
16. Drain flywheel housing.
17. Check air cleaner, remove, clean and install. If indicator shows "red" replace elements.
18. Check exhaust system for leaks, damage and security.
19. Check front and rear shock absorbers for leaks, damage and security.
20. Inspect front and rear springs for damage.
21. Check oil level in front axle, top-up if necessary.
22. Check oil level in intermediate axle, top-up if necessary.
23. Check oil level in rear axle, top-up if necessary.
24. Check oil level in transmission, top-up if necessary.
25. Check oil level in transfer case, top-up if necessary.
26. Check oil level in swivel pin housings, top-up if necessary.
27. Check brake, fuel and clutch pipes for chafing, leaks or corrosion.
28. Check condition of fanbelts including module air conditioning compressor drive belts.
29. Check radiator coolant, top-up if necessary.
30. Check brake servo hose for security and condition.

Table 3-4 Minor servicing (cont'd)

31. Check steering damper for leaks.
32. Check brake fluid reservoir, top-up if necessary.
33. Check clutch fluid reservoir, top-up if necessary.
34. Lubricate pintle hook.
35. Lubricate parking brake mechanical linkage.
36. Lubricate accelerator control linkage and pedal pivot.
37. Lubricate all hinges.
38. Lubricate propeller shafts and universal joints.
39. Check operation and security of spare wheel carrier.
40. Check security of additional equipment.
41. Check driving mirrors, door windows, hinges, catches and latches.

The following operations are to be performed by a Qualified Vehicle Mechanic:

42. Inspect front brake pads for wear, calipers for leaks and the condition of the discs.
43. Inspect the rear brake linings and drums for wear.
44. Inspect wheel cylinders for fluid leaks.
45. Adjust rear brakes.
46. Adjust parking brake.
47. Check condition and security of steering unit, joints and boots.
48. Clean fuel pump strainer.
49. Check and adjust fanbelts if necessary.
50. Check and adjust engine idle.
51. Check and adjust steering box.
52. Check and adjust headlights.
53. Check front wheel alignment.
- *54. Drain and refill cooling system.

Table 3-4 Minor servicing (cont'd)

The following operation is to be carried out by a Qualified Refrigeration Mechanic:

55. Replace receiver/drier.

* Coolant to be changed at 10 000 km, then every two years.

Table 3-5 Major servicing

The following operations are to be performed by the driver under supervision:

1. Start and warm up engine.
2. Stop engine, drain engine oil and refill.
3. Remove and replace oil filters.
4. Check condition of engine mountings.
5. Check engine hand throttle and stop control for connections and operation.
6. Check all lights and gauges for correct operation, report defects.
7. Check condition of radiator shroud and fins. Clean fins as necessary.
8. Retorque radiator hose connections.
9. Check operation of foot brake, hand brake and clutch.
10. Check operation of windscreen wipers and washers.
11. Check condition of windscreen wiper blades.
12. Check battery electrolyte levels (10 mm above plates) and security of terminals. Check for cleanliness and security.
13. Check for oil, fuel and coolant leaks. Report any defects.
14. Check tyres and wheels, inflate if necessary. Inspect rims for damage.
15. Drain fuel sedimenters.
16. Drain flywheel housing.
17. Check air cleaners, remove, clean, and install. Fit new elements if indicator shows "red".
18. Check exhaust system for leaks, damage and security.
19. Check front and rear shock absorbers for leaks, damage and security.

Table 3-5 Major servicing (cont'd)

20. Check front and rear springs for damage.
 - *21. Drain and refill front axle.
 - *22. Drain and refill intermediate axle.
 - *23. Drain and refill rear axle.
 - *24. Drain and refill swivel pin housings.
 - *25. Drain and refill transmission.
 - *26. Drain and refill transfer case.
 27. Check brake, fuel and clutch pipes for chafing, leaks or corrosion.
 28. Check condition of fanbelts including module air conditioning compressor drive belts.
 29. Check radiator coolant, top-up if necessary.
 30. Check brake servo hose for security and condition.
 31. Check steering damper for leaks.
 32. Check steering reservoir level, top-up if necessary.
 33. Check brake fluid reservoir, top-up if necessary.
 - *34. Renew brake servo filter.
 35. Check clutch fluid reservoir, top-up if necessary.
 36. Lubricate pintle hook.
 37. Lubricate parking brake mechanical linkage.
 38. Lubricate accelerator control linkage and pedal pivot.
 39. Lubricate all hinges.
 40. Lubricate propeller shafts and universal joints.
 41. Check propeller shaft coupling bolts.
 42. Check operation and security of spare wheel carrier.
 43. Check security of additional equipment.
 44. Check operation of module electrical components, including air conditioning, which requires a 240 volt supply to operate.
 45. Check driving mirrors, door windows, hinges, catches and latches.
- * Every second major service (40 000 km).

Table 3-5 Major servicing (cont'd)

The following operations are to be performed by a Qualified Vehicle Mechanic:

46. Inspect front brake pads for wear, calipers for leaks and the condition of the discs.
47. Inspect the rear brake linings and drums for wear.
48. Inspect wheel cylinders for fluid leaks.
49. Adjust rear brakes.
50. Adjust parking brake.
51. Check condition and security of steering unit, joints and boots.
52. Clean fuel pump strainer.
53. Check and adjust fanbelts, if necessary.
54. Clean and spray test fuel injectors.
55. Clean and test glow plugs.
56. Check engine compression.
57. Clean engine breather filter.
58. Check and adjust engine idle.
59. Check and adjust steering box.
60. Check front wheel alignment.

The following operations are to be performed by a Qualified Refrigeration Mechanic:

61. Check air conditioner suction and discharge pressure.
62. Check compressor noise level.
63. Check compressor oil level.
64. Evacuate system.
65. Replace receiver/drier.
66. Check mounting security of compressor.
67. Check compressor clutch bolts for tension.
68. Check drivebelt for tension.
69. Clean condensor core.
70. Check refrigerant hoses for wear.

Table 3-5 Major servicing (cont'd)

71. Check drain tubes for kinks or blockages.
72. Charge system and leak test all fittings and connections.
73. Test fan operation.

Tyre pressure (cold)

Highway:

front	350 kPa (50 psi)
intermediate	350 kPa (50 psi)
rear	350 kPa (50 psi)

Cross-country:

front	275 kPa (40 psi)
intermediate	275 kPa (40 psi)
rear	275 kPa (40 psi)

Sand:

front	225 kPa (33 psi)
intermediate	225 kPa (33 psi)
rear	225 kPa (33 psi)

SECTION 2 LUBRICATION

320. Table 3-6 details the lubricants required for vehicle servicing. However, refer to EMEI VEH G 209 for the approved list of lubricants and servicing instructions.

Table 3-6 List of Lubricants

Equipment	Lubricant	Capacity (litres)
Engine (including filters)	OMD-115	8.5
Transmission	OMD-115	2.7
Transfer Case (without PTO)	OMD-115	3.2
Front Axle	OEP-220	1.7
Intermediate Axle	OEP-220	2.3
Rear Axle	OEP-220	2.7
Swivel Pin Housings	OEP-220	0.35 (each)
Brake Master Cylinder	OX (Aust) 8	Fill to level
Clutch Master Cylinder	OX (Aust) 8	Fill to level
Steering Box (including reservoir)	OX 46	1.25
Chassis Lubrication	XG-274	As required
Wheel Bearings	XG-274	As required
Fanbelt Jockey Pulley	XG-274	As required
Air conditioning	Freon	As required

321. Fig. 3-3 illustrates the location of various lubrication and oil drainage/refill points around the vehicle.

NOTE

Run the engine or drive the vehicle as appropriate to warm oils before draining.

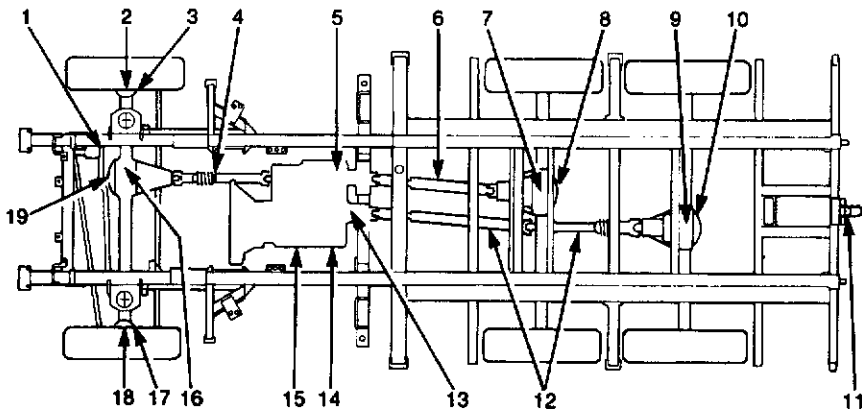

- | | |
|--|---|
| 1. Power steering reservoir | 11. Pintle |
| 2. Right hand swivel pin housing drain plug | 12. Rear propeller shaft |
| 3. Right hand swivel pin housing fill plug | 13. Transfer case fill plug |
| 4. Front propeller shaft grease nipples | 14. Transmission fill plug |
| 5. Transfer case drain plug | 15. Transmission drain plug |
| 6. Intermediate propeller shaft grease nipples | 16. Front axle drain plug |
| 7. Intermediate axle drain plug | 17. Left hand swivel pin housing fill plug |
| 8. Intermediate axle fill plug | 18. Left hand swivel pin housing drain plug |
| 9. Rear axle drain plug | 19. Front axle fill plug |
| 10. Rear axle fill plug | |

Figure 3-3 Lubrication and oil drain/refill points

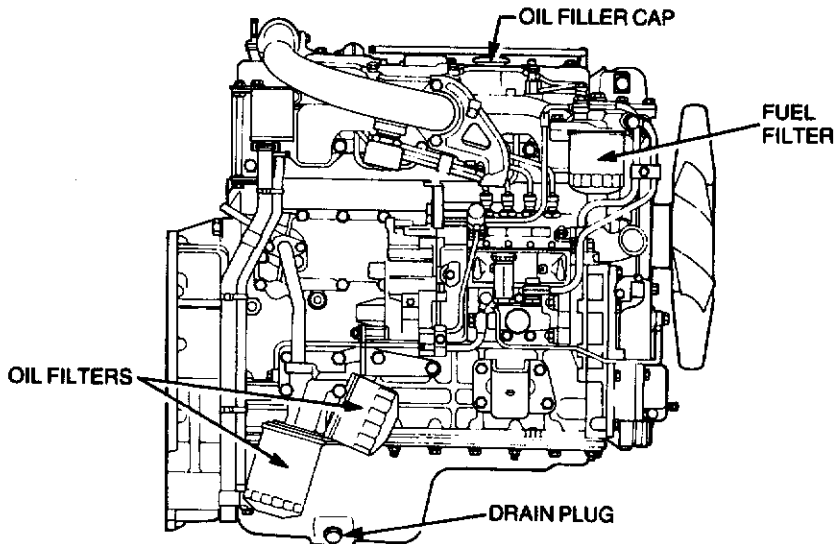

Figure 3-4 Engine — right hand side

Engine oil and oil filter change procedure

322. Run the engine until the engine coolant reaches normal operating temperature then shut down the engine. Remove the engine oil pan drain plug (see Fig. 3-4) and drain the oil into a suitable receptacle before the engine cools. Fit a new sealing washer on the drain plug and install the drain plug.

323. Unscrew each oil filter cartridge counter-clockwise, using a suitable oil filter removing tool if necessary (see Fig. 3-5). Apply a film of clean engine oil on the rubber seal of each new filter cartridge and install each filter. After the filter seal contacts the adapter, tighten the filter a further half a turn by hand only.

324. Fill the engine with the correct quantity of the recommended lubricant. Do not overfill. Check the level on the dipstick, then run the engine for about five minutes. Stop the engine and check the oil level on the dipstick. Add additional oil as required and check for leaks at the filters.

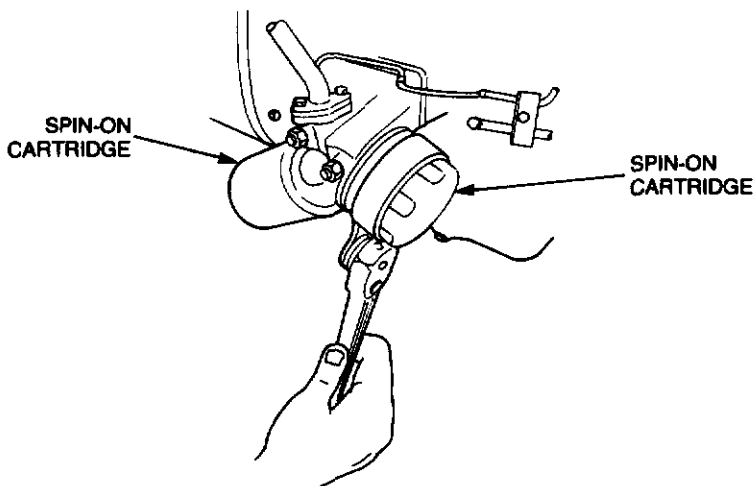

Figure 3-5 Oil filter removal

Transmission

325. The transmission drain plug is located on the left hand side of the transmission. Behind the drain plug is a filter which should be washed in clean fuel each time the transmission oil is drained. Allow the filter to dry completely before installing. Remove and wash the magnetic plug and remove all metallic particles. Install the plug.

326. The transmission fill plug is adjacent to the drain plug (see Fig. 3-6). Fill the transmission with the recommended lubricant to the bottom of the fill hole.

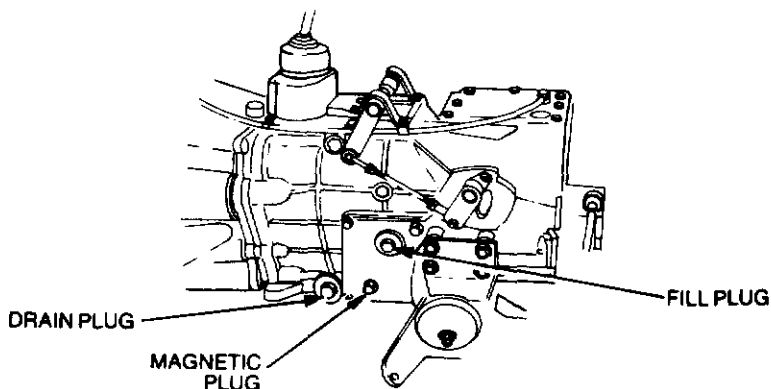

Figure 3-6 Transmission drain and fill plugs

Transfer case

327. The transfer case drain plug is located in the bottom of the PTO housing (see Fig. 3-7). The plug should be cleaned each time the transfer case oil is drained. Use a new sealing washer on installation.

328. The transfer case fill plug is located on the rear of the housing (see Fig. 3-7). Fill the transfer case with the recommended lubricant to the bottom of the fill hole.

329. Ensure that the transfer case breather is not restricted.

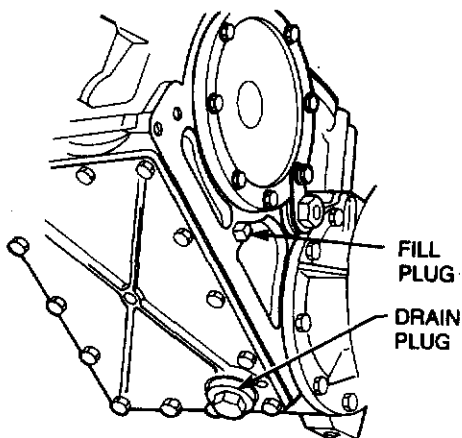

Figure 3-7 Transfer case drain and fill plugs

Intermediate axle

330. The drain plug is located on the bottom of the housing, while the fill plug is located on the rear cover (see Fig. 3-8). Fill the differential with the recommended lubricant to the bottom of the fill hole.

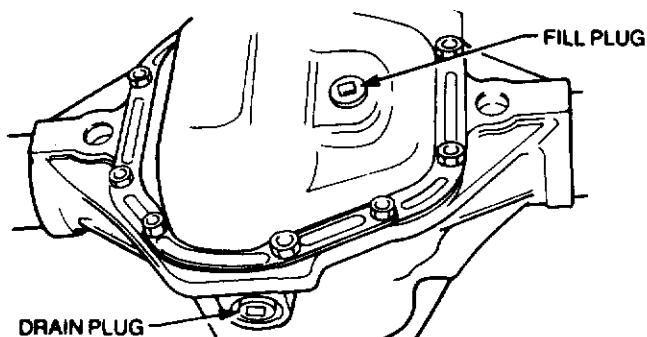

Figure 3-8 Intermediate axle drain and fill plugs

Rear axle

331. The drain plug is located on the bottom of the housing, while the fill plug is located on the rear cover (see Fig. 3-9). Fill the differential with the recommended lubricant to the bottom of the fill hole.

332. Ensure that the rear axle breather is not restricted.

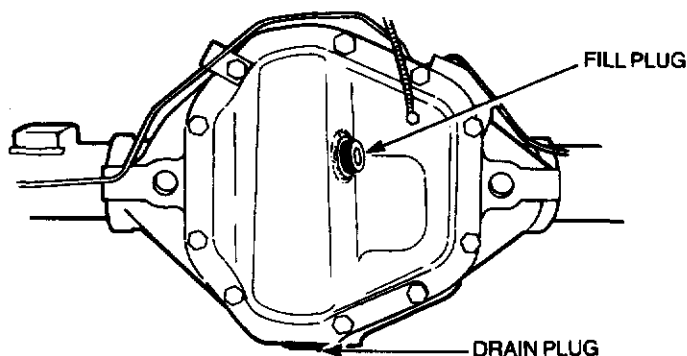

Figure 3-9 Rear axle drain and fill plugs

Front axle

333. The drain plug is located on the bottom of the housing, while the fill plug is located on the front of the housing. Fill the differential with the recommended lubricant to the bottom of the fill hole.

334. Ensure that the front axle breather is not restricted.

Steering reservoir/box

335. The steering reservoir/box are filled by removing the cap on top of the reservoir and filling the reservoir to the prescribed mark on the dipstick. No drain plug is fitted.

Swivel pin housings

336. The location of the drain plug and the fill plug is shown in Fig. 3-10. To drain the swivel pin housing, remove both the fill and drain plugs and drain the oil into a suitable receptacle. Fill the swivel pin housing with the recommended lubricant to the bottom of the fill hole.

Propeller shafts

337. The propeller shafts and universal joints are each fitted with a grease nipple (see Fig. 3-3 items 4, 6 and 12) and lubrication is required each service.

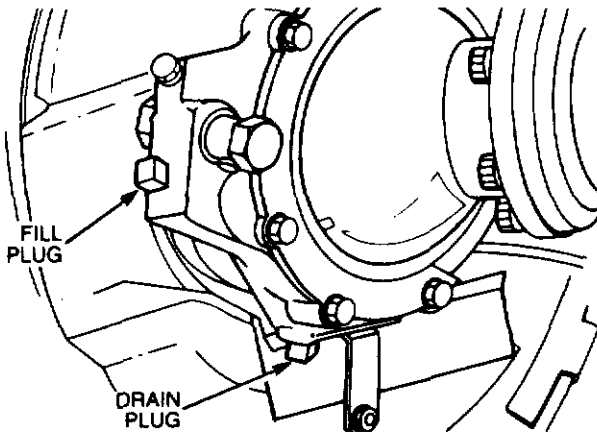

Figure 3-10 Swivel pin housing drain and fill plugs

Towing pintle

338. The towing pintle is fitted with one grease nipple and lubrication is required each service.

Fuel filter

339. Place a suitable container beneath the fuel filter, then, using a suitable filter-removing tool, remove the filter (see Fig. 3-11). Remove the filter rubber seal from the cover. Smear clean fuel on the

rubber seal of a new filter and install the new filter on the cover. Tighten the filter by hand until the rubber seal touches the cover face, then tighten a further half a turn. Bleed the fuel system as detailed in Chapter 3 Section 1.

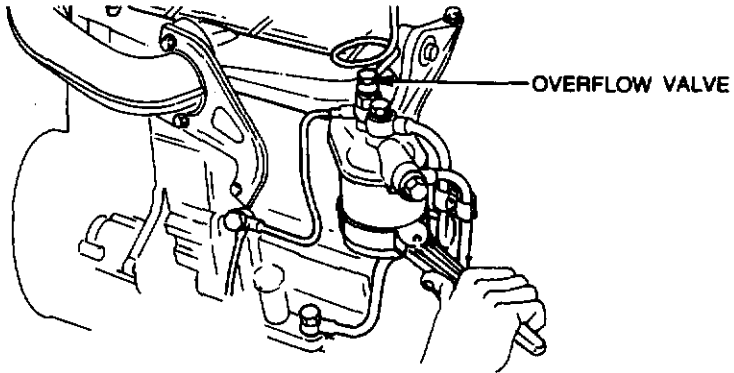

Figure 3-11 Fuel filter

Fuel sedimenters

340. Two fuel sedimenters, are located on the cabin rear crossmember forward of the rear spring mounting. A drain plug is fitted to allow the contents to be drained (see Fig. 3-12). Bleed the fuel system as detailed in Chapter 3 Section 1.

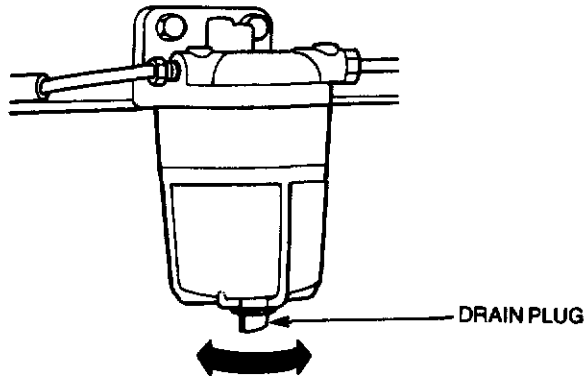

Figure 3-12 Fuel sedimenters

Air cleaner

341. The air cleaner elements will require cleaning or replacement when the signal indicator shows red. To clean or replace the air cleaner elements, proceed as follows:

- a. Remove the hose clamps securing the air inlet and outlet hoses to the air cleaner housing (see Fig. 3-13) then remove the two wing nuts from the clamp bolts. Carefully lift the air cleaner out of the mounting brackets.

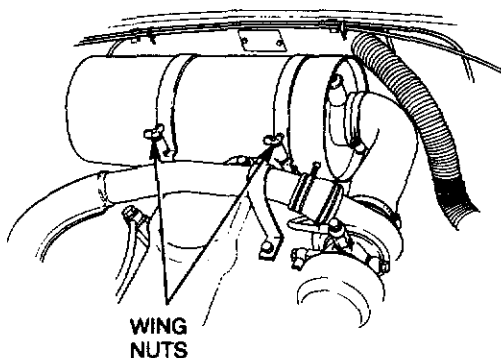

Figure 3-13 Air cleaner removal

- b. Remove the wing nuts securing the end cover and elements.
- c. Wipe out the air cleaner housing with a clean damp cloth. Remove and clean the dust valve (see Fig. 3-14).

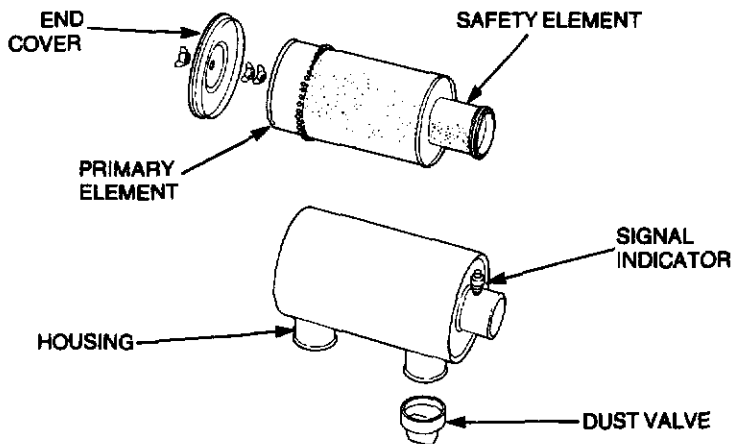

Figure 3-14 Air cleaner elements

- d. Clean or discard the primary element. If the element is to be cleaned, this can be achieved with compressed air or

washing with a non-sudsing general purpose detergent (see EME/ VEH A 591-1). If washing, ensure that the element is dry before installing. Do not clean the safety element.

- e. Install and secure the new or cleaned element, then secure the end cover.
- f. Install the air cleaner assembly and connect the air inlet and outlet hoses. Secure the hose clamps and tighten the wing nuts.
- g. Depress the reset button on the signal indicator to enable the red signal to be released.

Brake reservoir

342. Check the fluid level in the brake reservoir against the level marked on the reservoir. If necessary, remove the reservoir top and top-up with clean brake fluid OX (Aust) 8. See Fig. 3-15 for reservoir location.

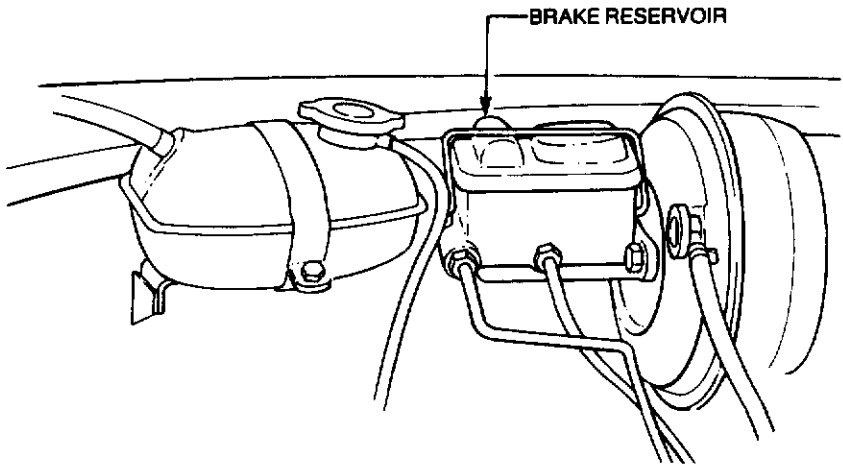

Figure 3-15 Brake reservoir

Clutch reservoir

343. Remove the reservoir cap and check that the fluid level in the clutch reservoir is up to the bottom of the filler neck. If necessary, top-up with clean brake fluid OX (Aust) 8. See Fig. 3-16 for reservoir location.

CLUTCH RESERVOIR

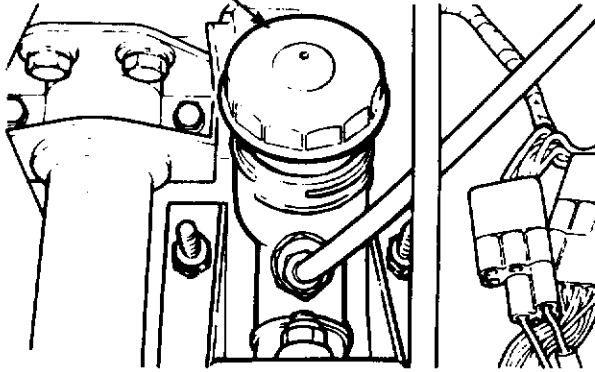

Figure 3-16 Clutch reservoir

Fanbelt jockey pulley

344. The 24 volt alternator fanbelt jockey pulley is fitted with one grease nipple and requires lubrication at each service (see Fig. 3-17).

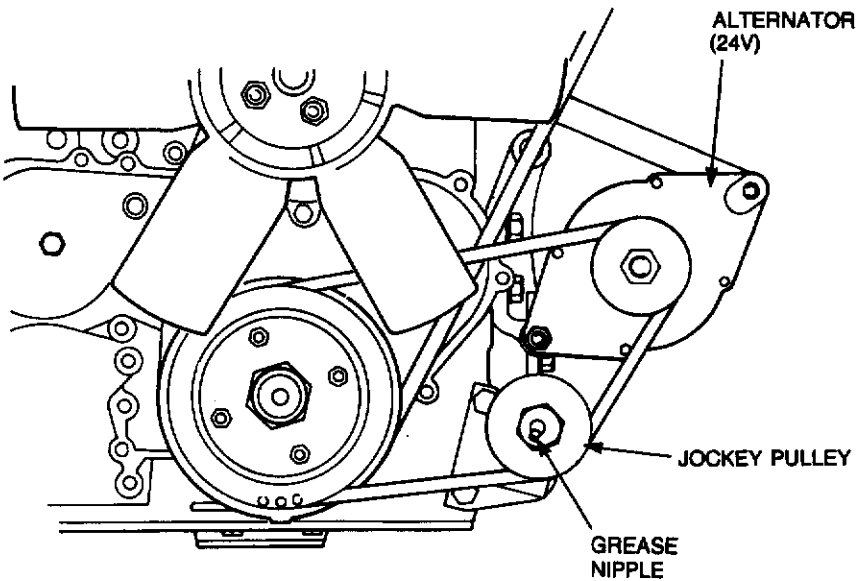

Figure 3-17 Jockey pulley lubrication

CHAPTER 4

ELECTRONIC REPAIR MODULE

SECTION 1 — EQUIPMENT DESCRIPTION

**SECTION 2 — EQUIPMENT OPERATING
INSTRUCTIONS**

SECTION 1

EQUIPMENT DESCRIPTION

Introduction

401. The electronic repair module is a self-contained unit which is mounted on the chassis of the truck, cargo, light, MC2 in place of the cargo tray. The module is of a steel frame fibreglass sandwich construction which can be mounted on the chassis of the truck, cargo, light, MC2 by two tradesmen in a fully equipped workshop in three days.

Operational and logistic concepts

402. This module provides two environmentally controlled work stations for two tradesmen to carry out repairs up to unit and field level under field conditions. The module will be outfitted by the user unit (with the specialist repair equipment held by the unit) in order to carry out its required role.

Ventilation and heating systems

403. A 240 volt variable speed fan assisted heater is mounted in the footwell at the front of the module. Four roof mounted vents are fitted to allow for air distribution within the module.

Lighting, electrical systems and controls

404. Ceiling lights

The main lighting utilizes eight 240 volt fluorescent tubes and is controlled by a switch secured to the roof adjacent to the rear door (see Fig. 4-1).

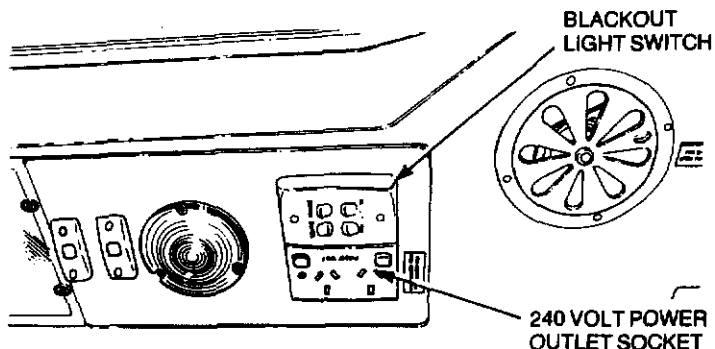

Figure 4-1 Ceiling light switches

405. Blackout function — module

A red rocker switch is located on the roof mounted switch panel (see Fig. 4-1) to control the blackout mode. When operated, the red ceiling lights are illuminated only.

406. Additional lights — 24 volt

Additional lighting is available utilizing the vehicles 24 volt electrical system. The four lights, which are fitted with an on/off switch, are positioned above the work bench on the left hand side and above the platform on the right hand side of the module (see Fig. 4-2).

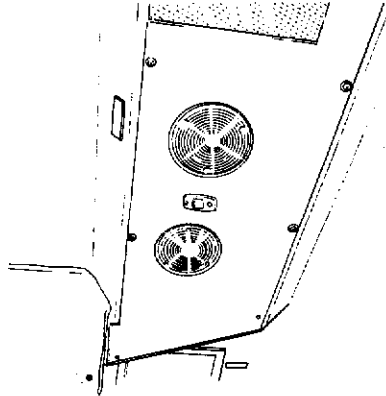

Figure 4-2 Module 24 volt lighting

407. High level reversing lights

Two clear lensed exterior lights are mounted on the door (see Fig. 4-3) and are controlled by the vehicles 12 volt lighting circuit as reversing lights.

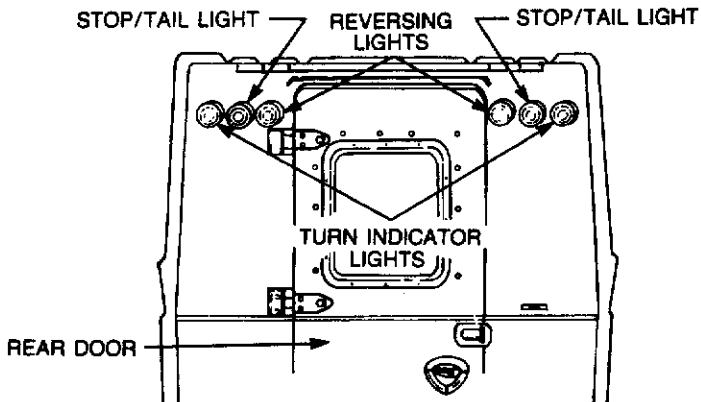

Figure 4-3 High level rear lights

408. High level indicator lights

Two amber lensed lights are mounted on the upper section of the door (see Fig. 4-3) and work in conjunction with the vehicles 12 volt lighting circuit to act as high level indicator lights.

409. High level stop and tail lights

Two red lensed lights are mounted on the upper section of the rear door (see Fig. 4-3), and work in conjunction with the vehicles 12 volt lighting circuit to act as high level stop and tail lights.

410. Fan assisted heater

The heater is located in the front right hand corner of the footwell (see Fig. 4-4), and incorporates a 3 position rotary switch for fan speed control, and a variable rotary switch for temperature control.

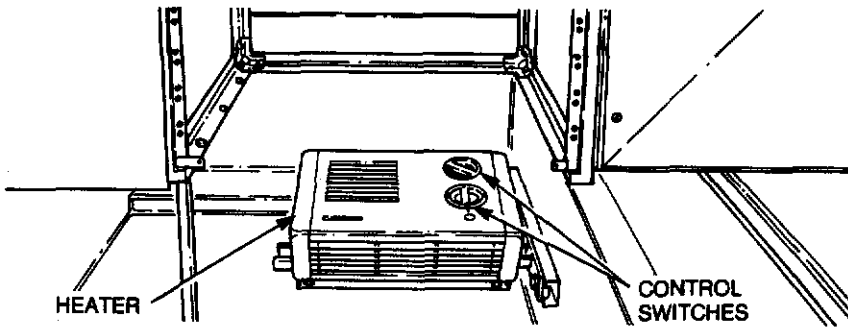

Figure 4-4 Fan assisted heater

411. Air conditioning

The air conditioning evaporator, air distributor and slide controls are combined in one unit, which is located on the upper front wall inside the module (see Fig. 4-5). The slide controls on the front of the unit enable the degree of coolness and the amount of air flow through the air conditioning to be regulated, while the outlet vents can be adjusted to direct the air flow to various points of the module.

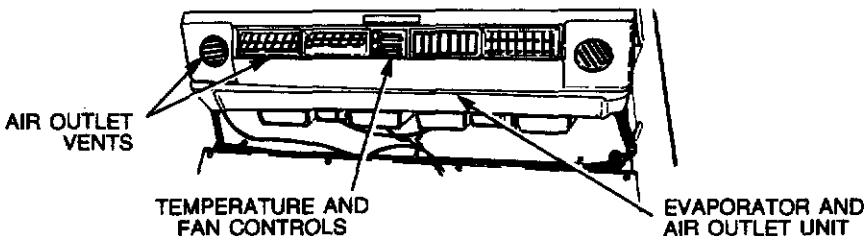

Figure 4-5 Air conditioning unit

412. Air conditioning compressor

The air conditioning compressor is located on the left hand side of the module above the auxiliary 24 volt battery storage rack (see Fig. 4-6). A 240 volt electric motor drives the compressor via a single Vee-belt. The system condenser is mounted as a separate unit on the centre front of the module roof.

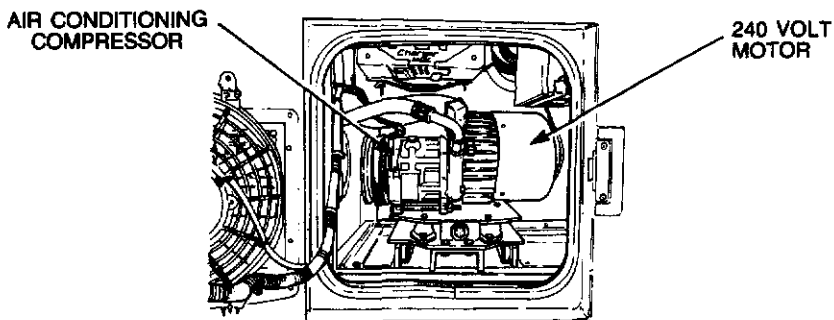

Figure 4-6 Air conditioning compressor

413. Power supply — 240 volt

Single and double switched power sockets are located in various positions on the module walls and ceiling. These 10 amp and 15 amp sockets supply mains voltage (240 volt) via an external source (generator or mains) to the power equipment being used.

414. Circuit breaker and power selection panel

The circuit breaker and power selection panel located on the inner front left hand corner of the module (see Fig. 4-7) houses circuit breakers to protect mains and 24 volt input and output voltages, power, heating and air conditioning controls and a voltmeter to indicate the charge state of the module batteries.

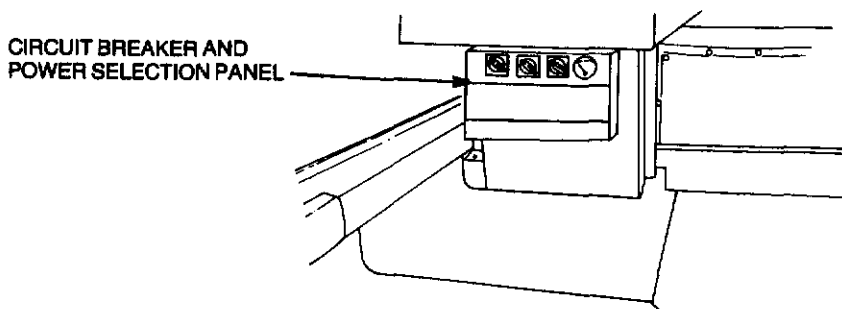

Figure 4-7 Circuit breaker and power selection panel

Electronic repair module fittings

415. Module construction

The module consists of welded galvabond steel tube framing which is covered by a fibreglass outer skin bonded to the frame. The inner panelling consists of two fibreglass shells that are positioned in the module and secured to the frame to form a fibreglass (urethane foam) sandwich.

416. Rear door

The rear door is manufactured from fibreglass, bonded to a galva-bond frame. The door provides access to the module and has the following features:

- a. A push in/out emergency exit/access window manufactured from clear plastic panel which can be covered internally by a heavy duty blackout curtain.
- b. A rubber sealing ring door seal to guard against the ingress of dust or water.
- c. Dual slam-latches are provided for the rear door, the lower latch is equipped with a spoon handle (internally) and a recessed dish handle on the outside of the door. These handles operate both latches simultaneously.

417. Exhaust vents

Two exhaust vents are located on the module roof and are semi-recessed into the rear of the roof panel. Air flow through the exhaust vents is controlled by rotating the shutters mounted in the ceiling below the exhaust vents. An exhaust fan is mounted in the ducting above each shutter. The fans are controlled by a common switch located forward of the right hand shutter. Two flap style air ventilators are fitted to the roof of the module adjacent to the lockers located above the front bench.

418. Rear step

Located centrally at the rear of the vehicle is a hinged step (see Fig. 4-8), which when swung down gives access to the module. When closed (in the up position) provides a weather seal to the footwell area of the module.

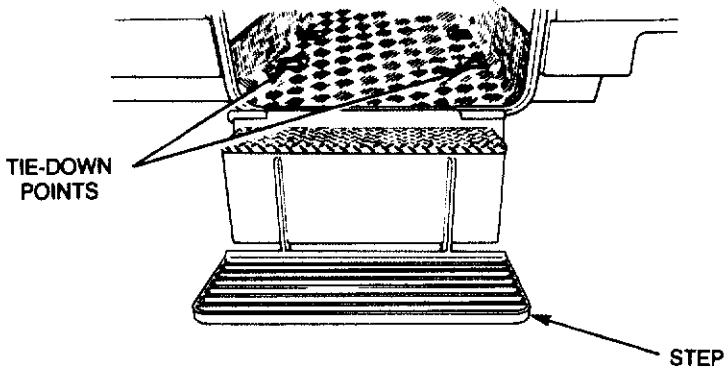

Figure 4-8 Rear step

419. Power inlet sockets

WARNING

The vehicle is to be earthed using the external earth spike prior to external 415/240 volt power sources being connected to the vehicle.

NOTE

The 415 volt power inlet socket is fitted with a Panclimatic, Ruggedised, FEMALE, 5 PIN, 45 A three phase power connector.

Located in the rear right hand corner of the module is a lockable flap which provides weather protection to the three inlet sockets (see Fig. 4-9). These sockets accept 240 volt single phase and 415 volt three phase power from mains or 2.5 kVA, 10 kVA or 15 kVA field generators.

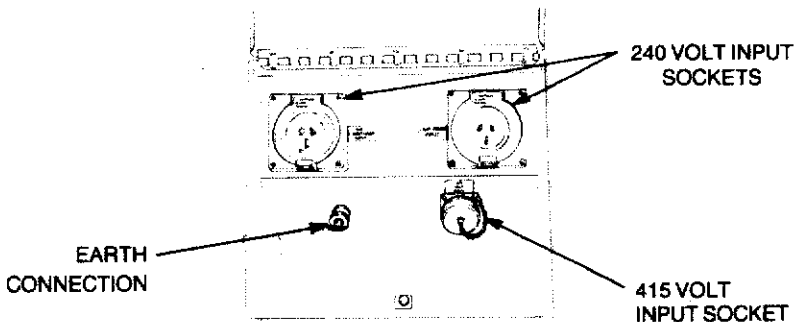

Figure 4-9 Power inlet sockets

420. Fire extinguisher

A 3.0 kg BCF fire extinguisher is secured, via a mounting bracket to the rear door (see Fig. 4-10).

421. First aid kit

The first aid kit is stored in a cabinet secured to the rear door (see Fig. 4-10).

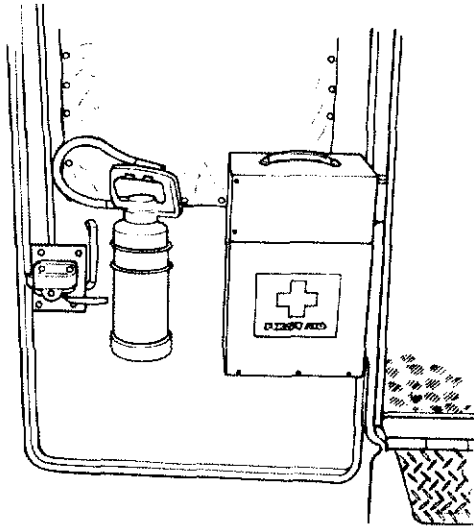

Figure 4-10 First aid kit and fire extinguisher location

Module interior layout

422. Power outlet sockets — 15 amp (Fig. 4-11 item 1)

Two 240 volt 15 amp single phase power outlet sockets are fitted to the module. The sockets are located on the left hand wall and the right hand side of the front wall.

423. DC test terminal (Fig. 4-11 Item 2)

Three 0 to 32 volt test terminals are installed above the benches in the module. Two are located on the left hand side wall, and one is located on the right hand side of the front wall.

424. Fluorescent lighting (Fig. 4-11 item 3)

Four 240 volt fluorescent lights are incorporated in the module, with two lights positioned above the left hand side bench and one each above the front bench and the platform on the right hand side of the module.

425. Emergency lamps (Fig. 4-11 item 4)

Four 24 volt emergency lamps with switches are installed in the ceiling. One is located above the left hand side bench, two are located above the platform on the right hand side of the module, and one is located above the front bench.

426. Air Inlet vents (Fig. 4-11 item 5)

Two air inlet vents are fitted to the front section of the roof. When not in use the vents can be sealed against the ingress of dust or moisture.

427. Publication cabinets (Fig. 4-11 item 6)

Two cabinets are provided in the upper front corners of the module to provide storage for maintenance manuals.

428. Air conditioning unit (Fig. 4-11 item 7)

The air conditioning unit located at the upper front of the module comprises an evaporator, filter, fan, adjustable outlets and slide lever controls. The air conditioning system operates off a 240 volt supply.

429. Blackout light (Fig. 4-11 item 8)

Two blackout lights are located on the ceiling, one above the right hand platform and one above the left hand platform. The switch for the blackout lights is located on the ceiling on the right hand side rear of the module (see Fig. 4-1).

430. Power outlet sockets — 10 amp (Fig. 4-11 item 9)

Four 240 volt, 10 amp single phase power outlet sockets are fitted to the module. Two sockets are located above the left hand bench, one socket above the front bench on the right hand side and one socket is located on the ceiling on the right hand rear of the module (see Fig. 4-1).

431. Stowage frames (Fig. 4-11 item 10)

Two stowage frames are secured to the platforms on the right hand side of the module. The frames are used for the stowage of four bin packs.

432. Tie-down rings (Fig. 4-11 item 11)

Six recessed tie-down rings are located in the floor for the purpose of securing tool boxes and/or loose equipment.

433. Fan assisted heater (Fig. 4-11 item 12)

The fan heater is located in the right hand corner of the module footwell. A 240 volt supply is required to operate the fan heater.

434. Drawers (Fig. 4-11 item 13 and 15)

Three groups of drawers are located under the side bench with each group comprising two shallow and two deep drawers. A gasket drawer is located in the centre section of the front bench.

435. Stowage bin (Fig 4-11 item 14)

The stowage bin located under the front bench, provides stowage for extension cables, etc.

436. Circuit breaker and power selection panel (Fig. 4-11 item 15)

The circuit breaker and power selection panel located on the front left hand side of the module provides protection for the 24 volt and 240 volt circuits. The panel also houses switches to control power, heating and cooling functions and a voltmeter to monitor module battery voltage.

437. Vice (Fig. 4-11 item 17)

The vice is secured to the top of the left hand side work bench.

438. Jerrican holders (Fig. 4 item 18)

Two jerrican holders are secured to the left hand platform for jerrican stowage.

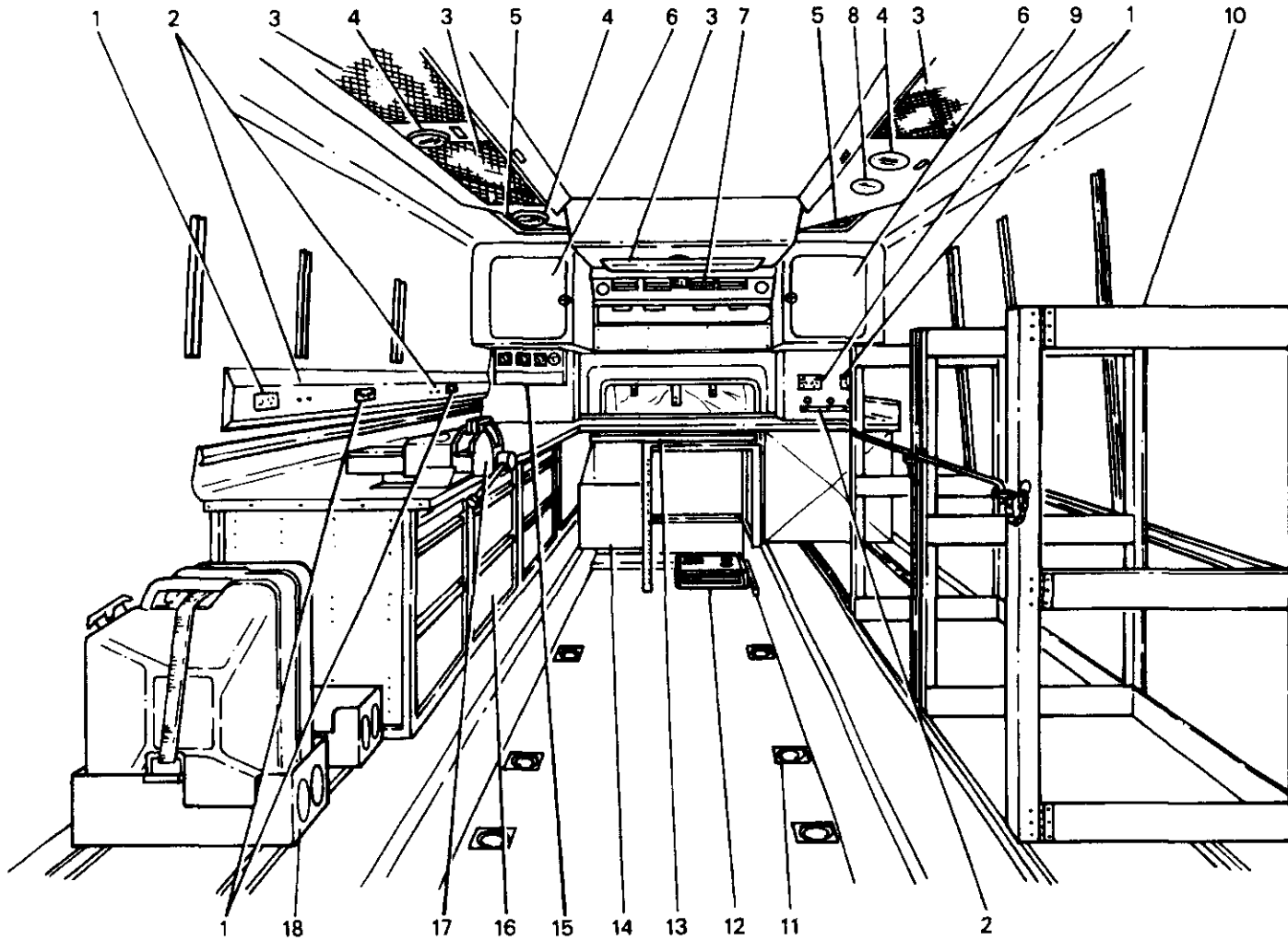

- | | |
|----------------------------------|---|
| 1. Power outlet sockets — 15 amp | 10. Stowage frames |
| 2. DC test terminal | 11. Tie-down rings |
| 3. Fluorescent lighting | 12. Fan assisted heater |
| 4. Emergency lamps | 13. Gasket drawer |
| 5. Air inlet vents | 14. Stowage bin |
| 6. Publication cabinets | 15. Circuit breaker and power selection panel |
| 7. Air conditioning unit | 16. Drawers |
| 8. Blackout light | 17. Vice |
| 9. Power outlet sockets — 10 amp | 18. Jerrican holders |

Figure 4-11 Module interior view

SECTION 2 EQUIPMENT OPERATING INSTRUCTIONS

General

WARNING

The vehicle is to be earthed using the external earth spike prior to external 415/240 volt power sources being connected to the vehicle.

439. The electronic repair module is a mobile self-contained repair facility providing stowage for repair equipment and spare parts. The correct operation and stowage of the equipment and parts is essential to enable repairs to be carried out efficiently.

Module access

440. Access to the module is gained through the rear outward opening door and by lowering the rear step.

Side Bench

441. The side bench can be located on either the left or right hand platform of the module. It is bolted to the clamping plates fitted in the guide rails (see Fig. 4-12). The bench houses six shallow and six deep drawers which are suspended on runners. Automatic locking devices enable each drawer to be locked when closed. To unlock a drawer raise its outer end clear of the locking pegs and slide it out.

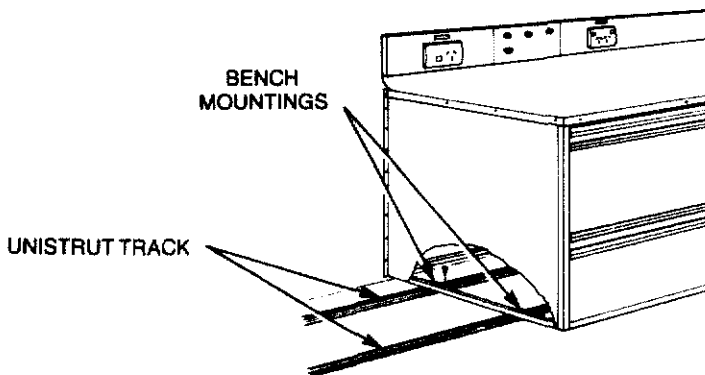

Figure 4-12 Side bench

Parts Bin Stowage Frames

442. The parts bin stowage frames are mounted to the guide rails with clamping plates (see Fig. 4-13). The frames can be mounted on either left or right hand platform (dependant on the side bench location). To insert a bin pack, remove the locking rod safety pin and lift the locking rod free of its locating lug. Swing the hinged upright with rod outwards and slide the bin pack into position. Close the hinged upright, insert the locking rod into its locating lug and insert the safety pin.

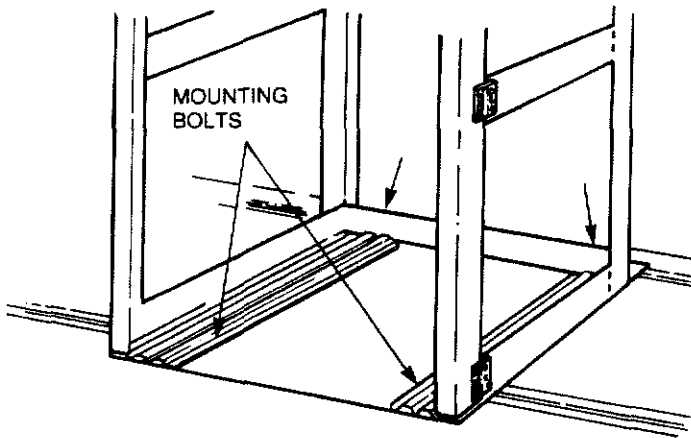

Figure 4-13 Bin pack mounting frame

**SIMPLEX COMPLETE EQUIPMENT SCHEDULE 12107/1
TRUCK, ELECTRONIC REPAIR, LIGHT, MC2 -- LANDROVER 110
LIABILITY CODE 73220/01**

ITEMS SUPPLIED/ISSUED WITH TRUCK

**PART 1— Principal Items
NIL**

PART 2A — Items Essential to Operation of Equipment

Item No.	NATO Stock No.	Designation	Unit of Issue	Quantity per sub-assembly	Quantity per equipment	Expendability classification	Foot-note
1	5120-66-048-8548	Baseplate, Jack, Wooden, 12 in x 12 in. x 2 in.			1	X	
2	6140-66-065-0681	Battery, Storage, 12V, 11 Plate, 80 Amp/hr, 305 mm 305 mm Lg x 175 mm x 225 mm H			1	N	
3	NIC	Battery, Storage, 15 Plate, 93 Amp/hr, 343 mm Lg x 173 mm W x 245 mm H (Exide Cycle X Plus, C X 4)			2	N	
4	8115-66-022-0114	Box, Small Parts, Plastics, 4-1/2 in. Lg x 2-1/2 in. W x 2-3/4 in. H, W/Lid			1	N	
5	7530-66-107-1001	Book, Record, TGM 120, Record Book for Service Equipment			1	X	A

Item No.	NATO Stock No.	Designation	Unit of Issue	Quantity per sub-assembly	Quantity per equipment	Expendability classification	Foot-note
6	4210-66-089-8751	Extinguisher, Fire, Vaporizing Liquid, Bromochlorodifluoromethane, 1.50 kg Capacity, Stored Pressure, Regulated Discharge type		1	1	N	
7	4910-66-054-4679	Gauge, Tyre pressure, Self Contained, Portable Bar Type, 20 to 140 PSI Range, 2 PSI Calibrations, 165 mm O/A Lg W/Pocket Clip		1	1	X	
8	2610-66-010-7864	Inner Tube, Pneumatic Tyre, Light Truck, 7.50-16, TR15 Valve		1	1	N	B
9	5120-66-012-6101	Jack, Hydraulic, Hand, Double Lift, 7-1/2 in. Closed H, 17 in. Extended, 5 Ton W/Handle		1	1	N	
10	5120-66-014-0251	Pliers, Combination Side Cutting, W/Pipe Grip and Serrated Jaws, Insulated, 6 in. Norm. Lg		1	1	N	
11	4320-00-852-9036	Pump, inflating, Manual, Hand Operated, Single Action, W/30 in. Lg Hose and Adaptor		1	1	X	
12	5140-66-067-5483	Roll, Tools and Accessories, Cloth Coated Nylon, 2 Pockets, 14 Loops, 690 MH mm x 350 mm W, W/2 Flaps		1	1	X	
13	5120-66-024-7832	Screwdriver, Crosstip, Cellulose Acetate Handle Phillips No. 3 x 150 mm Lg Blade 3-6		1	1	X	
14	5120-66-026-0206	Screwdriver, Flat Tip, Cellulose Acetate Handle, 8 mm W Tip x 150 mm Lg Blade		1	1	N	
15	NIC	Tyre, Pneumatic, Light Truck, Tubed 7.50 R016 Lt, 10 ply Olympic Steeltrek		1	1	N	B
16	NIC	Wheel Chocks		2	2	N	

Item No.	NATO Stock No.	Designation	Unit of issue	Quantity per sub-assembly	Quantity per equipment	Expendability classification	Foot-note
17	NIC	Wheel, Pneumatic Tyre 6.00 x 16			1	N	B
18	5120-66-016-1257	Wrench, Open End, Fixed, Double Ended, 15 Degree Offset, 1/2 in. and 9/16 in. A/F			1	N	
19	5120-66-013-6747	Wrench, Open End, Adjustable, 250 mm Nom. Size			1	X	
20	5120-66-016-0098	Wrench, Ring, Bi-Hexagon, Double Offset, Double Ended, 1/2 in. and 9/16 in. A/F			1	X	
21	NIC	Wrench, Socket, Wheelnut, 4 Way Type 15/16 in. and 1-1/16 in. x 16. in. Nom. Lg O/A			1	N	

Part 2B — Optional Equipment — To Be Demanded Separately

NIC

1 N

Equipment Kit, Vehicular Light, MC2, 6x6, 4 Cylinder
Diesel Engine, Manual Transmission, Shelter Installation,
Small 12V Electrical System, Land Rover Model 110 Series
(PSCES) 004/86)

Footnotes

- A. Individual pages to be demanded as per User Catalogue for Stationary Supplies (Forms).
- B. Spare.

SIMPLEX COMPLETE EQUIPMENT SCHEDULE 12122/1 EQUIPMENT KIT

ITEMS REQUIRED TO MAKE UP THE EQUIPMENT KIT

PART 1— Principal Items NIL

PART 2A — Items Essential to Operation of Equipment

Item No.	NATO Stock No.	Designation	Unit of issue	Quantity per sub-assembly	Quantity per equipment	Expendability classification	Foot-note
1	5110-66-011-0377	Axe, Single Bit, 2 kg, 820 mm Lg			1	X	
2	7240-66-021-5710	Can, Dispensing, Funnel Top, Tin Plate, 1 pint Capacity, W/O Handle			1	X	
3	7240-99-802-2405	Can, Gasoline, Military, Steel, 22 Litre			1	X	
4	8110-66-016-0717	Can, Screw Cap, Oil Rect Shape, 5 Litre			1	N	
5	7240-66-054-8602	Can, Water, Military, Plastics, 22 Litre			1	X	
6	2640-00-060-3550	Cap, Pneumatic Valve, Brass			7	X	
7	4010-66-086-8464	Chain Assembly, single Leg, Alloy Steel, 4 m Lg, 0.500 in. Dia, SWL 10 080 lb Hook Other End 4 m Lg, 10 080 lb SWL			1	N	
8	5120-66-012-6821	Handle, Mattock-Pick, 5 lb, Pick			1	X	
9	5340-66-025-0498	Holder Key, Steel, 3/4 in. ID			1	X	
10	5970-66-018-8475	Insulation Tape, Electrical, Black, 18 mm W x 33 m Lg			1	X	

Item No.	NATO Stock No.	Designation	Unit or Issue	Quantity per sub-assembly	Quantity per equipment	Expendability classification	Foot-note
11	6240-00-155-7900	Lamp, Incandescent, 12V, 6 to 21 CP, Double Contact Bayonet Base, 'B' Shape, Clear		2		X	
12	6240-66-026-0478	Lamp, Incandescent, 12V, 40/50 W, Double Contact Prefocus Base, 'T' Shape, Clear		2		X	
13	6240-66-010-7460	Lamp, Incandescent, 12V, 5 W, Single Contact Bayonet, Candelabra Base, 'G' Shape, Clear		3		X	A
14	6240-66-010-8161	Lamp, Incandescent, 12V, 21 W, Single Contact Bayonet, Candelabra Base, 'S' Shape, Clear		2		X	
15	6240-66-022-6561	Lamp, Incandescent, 12V, 3 W, Single Contact Bayonet (BA 15S) Base, G-6 Shape, Clear		2		X	
16	6230-99-942-7876	Light, Extension, C/W Cable and Plug, W/O Globe		1		N	
17	5340-66-020-2790	Padlock, Brass, Solid Case, Steel Shackle, 45 mm in. W, 19 mm Shackle Clearance		3		X	
18	5120-66-012-6893	Pick, Digging, W/O Handle, 5 lb.		1		X	
19	4030-66-123-1450	Shackle, Dee, Alloy Steel, Quality Grade S, 19 mm Nom Size, C/W Metric Thd Collared Eye Pin, 4.7 Tonne WLL, Zinc Coated		2		X	
20	5120-66-093-8563	Shovel, Hand, GS, Rd Point Blade, Plastic D-Handle, Black or Dark Green, 35-1/2 in. LG O/A		1		X	
21	9905-66-018-3897	Sign, Warning, Portable, Motor Vehicle		3		X	
22	9905-66-048-0206	Tag, Marker, Brass, Rd, 1-1/4 Dia.		2		X	
23	2640-00-050-1229	Valve Core, Pneumatic Tyre		7		X	
24	6145-66-014-2971	Wire, Electrical, No. 20 SWG	RL	1		X	

Item No.	NATO Stock No.	Designation	Unit of Issue	Quantity per sub-assembly	Quantity per equipment	Expendability classification	Foot-note
----------	----------------	-------------	---------------	---------------------------	------------------------	------------------------------	-----------

Part 2B -- Optional Equipment -- To Be Demanded Separately

Footnotes

A. One is for the light, the remainder are spares.

INDEX

A

	Para.
Accelerator pedal	70
Accessories, electrical	49-82
Additional lights — 24 volt	406
Air cleaner	341
Air conditioning	411
Air conditioning compressor	412
Air conditioning unit	428
Air distribution control	55
Air inlet vents	426
Air temperature control	54
Angles, approach and departure	35
Auxiliary power socket	51
Axle, front	9, 42, 333
Axle, intermediate	330
Axle, rear	10, 44, 331

B

Battery box	99
Battery replacement — 24 volt	235
Blackout function — module	405
Blackout lighting	50
Blackout lights	429
Bleeding the fuel system	315
Body and chassis fittings	84-108
Bonnet, opening	312
Bonnet release	69
Brake, parking	48, 77, 228
Brake pedal	71
Brake reservoir	342
Brakes, service	46, 47
Brakes, vehicle	15
Braking	226
Bridge classification	31
Bridge classification sign	107

C

Cab dome light switch.....	66
Cabin heating.....	53, 54, 55
Cabin ventilation.....	49
Cabin seating.....	83
Camouflage net lashing points.....	108
Capacities.....	29
Carrying capacity.....	26
Ceiling lights — module.....	404
Changing a wheel.....	233
Chassis.....	16
Chassis and body fittings.....	84-108
Cigar lighter.....	76
Circuit breaker and power selection panel.....	414, 436
Classification bridge.....	31
Classification sign, bridge.....	107
Cleaner, air.....	341
Clutch.....	6, 224
Clutch pedal.....	75
Clutch reservoir.....	343
Centre of Gravity (C of G) designation plate.....	105
Combination switch.....	59
Construction — module.....	415
Controls, air distribution.....	55
Cooling system.....	2
Coolant temperature gauge.....	63
Cross-country driving.....	231

D

Data plate, servicing.....	101
Data summary.....	1-27
DC test terminal.....	423
De-ditching tools.....	93
Dimensions.....	28
Drawers.....	434
Driving habits.....	222-232

E

Electric windscreen washers.....	65
Electrical.....	307

	Para.
Electrical, accessories	49-82
Electrical system.....	18
Electrical system ignition/start switch	72, 220
Electrical trailer connection sockets	95
Electronic repair module construction	85, 415
Emergency lamps	425
Engine.....	1, 38
Engine accessory drive	3
Engine oil and oil filter change procedure	322-324
Engine starter.....	5
Engine, starting	220
Engine, stopping	227
Engine temperature	222
Engine warning light cluster	62
Equipment description — module	401-438
Equipment operating instructions — module	439-442
Exhaust vents — module	417
External lighting	19
Extinguisher, fire	92, 420

F

Fan control	53
Fan assisted heater	410, 433
Fan heater controls	53
Fanbelt jockey pulley.....	344
Filter, fuel.....	339
Filter, oil	322-324
Fire extinguishers.....	92, 420
First aid kit	421
First parade servicing	301-305
Fluorescent lighting	404, 424
Flywheel housing drain.....	228, 229
Foot brake pedal.....	71
Fording depth.....	30, 229
Front axle.....	9, 42, 333
Front suspension	12, 43
Fuel filter.....	339
Fuel gauge.....	61
Fuel sedimenters	340
Fuel switch	56
Fuel system.....	4

	Para.
Fuel system, bleeding	315
Fuse box.....	80
Fuses	24

G

Gauge, coolant temperature	63
Gauge, fuel.....	61
Gear changing	225
Gear lever	78
Good driving habits	222-232
Ground clearance.....	32

H

Habits, driving	222-232
Halts on the march	309, 310
Hand throttle	68
Hazard warning switch.....	67
Headlights/park lights.....	59
Heater fan control switch.....	53
Heating and ventilation systems — module.....	403, 410, 411
High level indicator lights.....	408
High level reversing lights.....	407
High level stop and tail lights.....	409
High/low beam dipper switch.....	59
Horn, electric	59

I

Ignition switch	72, 220
Instruments	49-82, 223
Instrument lights	52
Intermediate axle.....	330
Internal dimensions — module	28
Introduction.....	36
Introduction — module	401

J

Jacking plate.....	104
Jerrican stowage	90, 438

K

L

Last parade servicing	311
Light, blackout.....	429
Light, map reading	82
Lighting, blackout.....	50
Lighting, external 12 volt	19
Lighting, internal 12 volt	20
Lighting, internal 24 volt	21
Lighting, internal 240 volt.....	22
Lighting, military	23
Lighting, reduced	50
Lights, additional — 24 volt.....	406
Lights ceiling — module	404
Lights, instrument	52
Lights, warning	62
List of agents.....	216
Lubrication.....	320-344

M

Main lighting switch	73
Maintenance, periodical	316
Map reading light	82
Military lighting	23
Mirrors, rear vision	98
Module access.....	440
Module construction.....	415
Module interior layout.....	422-438
Module internal dimensions.....	27
Moving off and running.....	308
Moving the vehicle.....	221

N

Nomenclature plate	100
Normal, blackout and reduced lighting switch	50

O

Odometer	60
----------------	----

	Para.
Oil filter and engine oil change procedure	322-324
Opening bonnet for servicing access	312
Operational and logistic concepts	37
Operational and logistic concepts — module	402
Operation, vehicle	217-234

P

Panel light dimmer control	52
Parking	228
Parking brake	48, 77
Parts bin stowage frames	442
Pedal, accelerator	70
Pedal, brake	71
Pedal, clutch	75
Performance	25
Periodical maintenance	316
Pintle, towing	96, 338
POL stowage	90, 438
Plate, C of G designation	105
Plate, jacking	104
Plate, nomenclature	100
Plate, servicing data	101
Plate, shipping data	102
Plate, towing and dyno test data	103
Propeller shafts	11, 337
Power inlet sockets	419
Power outlet sockets	422
Power outlet sockets — 10 amp	430
Power supply — 240 volt	413
Publication cabinets	427

Q

R

Radiator coolant	314
Rear axle	10, 44, 331
Rear door	416, 440
Rear side windows	89
Rear step	418, 440
Rear suspension	13, 45

	Para.
Rear vision mirrors.....	98
Rear window.....	87
Reduced lighting.....	50
Reservoir, brake.....	342
Reservoir, clutch.....	343
Reservoir, steering.....	335
Rifle clips and butt boxes.....	91
Roof hatch.....	88

S

Seat belts.....	97
Seating, cabin.....	83
Sedimenters, fuel.....	340
Service brakes.....	46, 47
Servicing, data plate.....	101
Servicing, first parade.....	301-305
Servicing, last parade.....	311
Shafts, propeller.....	11, 337
Shift pattern, main transmission.....	78
Shift lever, main transmission.....	78
Shift lever, transfer case.....	79
Shift pattern, transfer case.....	79
Shipping data plate.....	102
Side bench.....	441
Sign, bridge classification.....	107
Sign, unit/formation.....	108
Slinging and tie-down points.....	34
Spare wheel stowage.....	94
Special requirements.....	317
Speedometer and odometer.....	60
Starter switch.....	72
Starting, engine.....	220
Start the vehicle.....	306
Steerable front drive axle.....	42
Steering.....	14
Steering reservoir/box.....	335
Stopping the engine.....	227
Stowage.....	86
Stowage frames.....	431, 442
Stowage bin.....	435
Stowage, POL.....	90, 438

	Para.
Suspension, front	12, 43
Suspension, rear	13, 45
Switch, turn indicator.....	59
Switch, hazard warning.....	67
Switch, headlights/park.....	73
Switch, high/low dipper	59
Switch, ignition/start	72
Swivel pin housings.....	336
System, electrical	18

T

Temperature coolant gauge	63
Throttle, hand	68
Tie-down rings	432
Towing the vehicle	234
Towing and dyno test data plate.....	103
Towing pintle.....	96, 338
Trailer connection socket	95
Transfer case.....	8, 40, 327
Transfer case control switch	57
Transfer case shift lever	79
Transfer case shift pattern	79
Transmission	7, 39, 325
Transportability.....	33
Tyres and wheels	17

U

Unit/formation signs	106
----------------------------	-----

V

Vehicle body construction	84
Vehicle nomenclature plate.....	100
Vehicle operation	217-234
Vehicle, start.....	220
Ventilation	49
Ventilator control	49
Ventilation and heating systems — module.....	403, 410, 411
Vice	437
Voltmeter — 24 volt	58
Voltmeter — 12 volt	64

W

Warning light cluster	62
Warranty and repair.....	201-216
Washers, windscreen.....	65
Wheel changing.....	233
Wheels and tyres.....	17
Windscreen washer and wiper switch	65

NOTES

NOTES

NOTES



NOTES



NOTES



NOTES

