

TRUCK, HEAVY, MC3, MACK - ALL VARAINTS

RELOCATION OF AIR BAG SUSPENSION FILTER

MODIFICATION INSTRUCTION

This instruction is authorised for use by command of the Chief of Army. It provides direction, mandatory controls and procedures for the operation, maintenance and support of equipment. Personnel are to carry out any action required by this instruction in accordance with EMEI GENERAL A 001.

Introduction

1. During the air bag suspension modification, the air bag suspension filter was fitted in an unsuitable location on a large number of the Mack fleet. The filter was fitted above the ride height adjusting rods, resulting in the rod puncturing the filter.
2. This instruction details the relocation of the air bag filter assembly to ensure that it cannot be damaged by suspension components.
3. **Associated Publications.** Reference may be necessary to the latest issue of the following documents:
 - a. EMEI Workshop A 850 - Modifications, Trial Modifications and Local Modifications to Equipment;
 - b. EMEI Workshop A 851 - Recording Modifications to Equipment - Use of Modification Record Plates and Documentary Requirements;
 - c. EMEI General P section - Stores Procedure; and
 - d. EMEI Vehicle G Series.
4. **Authority.** This document is issued on the authority of NFM Mdm/Hvy B Vehicles (MSLMD).

General

5. **Modification Application.** This modification is to be applied to all Truck, Heavy, MC3, Mack vehicles that currently have the airbag filter assembly mounted on the right-hand chassis rail, above and slightly forward of the rear chassis cross-member (above the ride height-adjusting rod).
6. **Items Affected.** This modification alters the air bag suspension filter.
7. **Priority - Group 2.** All applicable equipment is to be modified:
 - a. when next in a workshop for Light, Medium or Heavy Grade repair, or
 - b. prior to issue from depot or pool stock.

NOTE

Where modification would delay priority issues of depot or pool stock, equipment may be issued unmodified providing the equipment record book is endorsed appropriately.

8. **Action Required.** Actions detailed in this instruction are to be performed by RAEME workshops (or unit tradespersons) authorised to carry out Light, Medium or Heavy Grade repairs.

NOTE

On receipt of this instruction, enter all relevant information other than date completed in the modifications section of the vehicle Record Book for Service Equipment (GM 120).

9. **Estimated Manhours.** For initial planning purposes only, it is estimated that this modification will take 1 manhour to perform.
10. **Stores Required.** The stores required are listed in Table 1. All stores are to be demanded through normal supply channels and are available from SQLG.
11. **Items to be Removed.** Nil

Detail

12. **Relocation of Air Bag Filter Assembly.** The procedure is as follows:

- a. Remove the two bolts securing the air bag filter assembly to the chassis bracket and remove housing (airlines remain connected).

NOTE

Cable ties may need to be removed or repositioned to allow sufficient movement of airlines.

- b. Fit new bracket (Table 1, Item 2) to existing bracket with overlap facing rearward and secure with bolt (Table 1, Items 3 to 5) through forward hole. Figure 1 details the location of new bracket.
- c. Refit airbag filter assembly, using original bolts, to remaining holes of new bracket.

NOTE

Bolt through centre hole of new bracket should secure air bag filter assembly and new bracket to the rear hole of the existing bracket.

- d. Secure airlines, as necessary with cable ties.

NOTE

Air bag filter should now be located directly above the rear chassis crossmember.

13. Post Modification Testing. Deflate air bag suspension and ensure that air bag filter is clear of the ride height adjusting rod and other suspension components.

14. Recording Action. On completion of the modification, the following action is to be taken:

- a. Deface the number 24 on the equipment modification record plate.

b. Complete the modification details in the equipment Record Book for Service Equipment (GM 120).

c. Forward the modification completion details to:

NFM Mdm/Hvy B Vehicles
MSLMD
Army Equipment Management Agency
GPO Box 840J
MELBOURNE VIC 3001

d. The return should include the following information:

- (1) Modification No: EMEI Vehicle G 797-15.
- (2) Unit: eg 1 CSSB.
- (3) Equipment ARN.
- (4) Completion Date.

Table 1 - Stores Required

Item	NSN	Mfr Part No	Designation or Description	Unit of Issue	Qty per Kit	Qty per Equip
1	2590-66-145-0680	3QK19403K	Kit, Air Bag Filter Relocation Bracket (consists of items 2, 3, 4 and 5)	kit		1
2		3QK19403M	Bracket	ea	1	1
3		4AX3	Bolt, 3/8 x 11/2 unc	ea	1	1
4		23AX333	Nut, nyloc, 3/8 unc	ea	1	1
5		37AX472U	Washer, flat, 3/8	ea	1	1

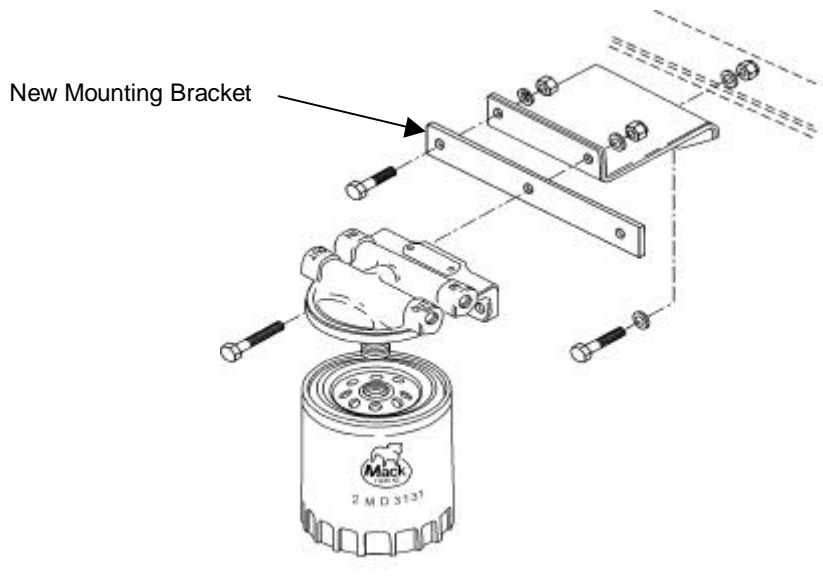

Figure 1 – Airbag Filter Mounting Bracket

END

List VEH G 50.0 - Code 4 (Job No 9702017)