

TRUCK, HEAVY, MC3, MACK - ALL VARIANTS

RELOCATION OF FRONT HUB BREATHERS

MODIFICATION INSTRUCTION

This instruction is authorised for use by command of the Chief of Army. It provides direction, mandatory controls and procedures for the operation, maintenance and support of equipment. Personnel are to carry out any action required by this instruction in accordance with EMEI GENERAL A 001.

Introduction

1. The front hub breathers are located in a position that is difficult to access for cleaning, and prone to being blocked by dirt, mud and grease. This results in the failure of the inner hub seals.

2. This instruction details the fitting of a vent tube, enabling the breather to be relocated to a more accessible location. This will improve access to the breather for servicing and maintenance.

3. *Associated Publications.* Reference may be necessary to the latest issue of the following documents:

- a. EMEI Workshop A 850 – Modifications, Trial Modifications and Local Modifications to Equipment;
- b. EMEI Workshop A 851 – Recording Modifications to Equipment – Use of Modification Record Plates and Documentary Requirements;
- c. EMEI General P section – Stores Procedure;
- d. EMEI Vehicle G Series; and
- e. EMEI Workshop D 700-1 – Painting of Guns, Vehicles and GS Equipment.

4. *Authority.* SCA(A) (AMMA) 963/98 of 25 Aug 98 is the authority to carry out this modification.

General

5. *Modification Application.* This modification is to be applied to all variants except the Bitumen Layer.

6. *Items Affected.* This modification alters the steerable drive end assembly.

7. *Priority - Group 2.* All applicable equipment is to be modified:

- a. when next in a workshop for Light, Medium or Heavy Grade repair; or
- b. prior to issue from depot or pool stock.

NOTE

Where modification would delay priority issues of depot or pool stock, equipment may be issued unmodified providing the equipment record book is endorsed appropriately.

8. *Action Required.* Actions detailed in this instruction are to be performed by RAEME workshops (or unit tradespersons) authorised to carry out Light, Medium and Heavy Grade repairs.

NOTE

On receipt of this instruction, enter all relevant information other than date completed in the modifications section of the vehicle Record Book for Service Equipment (GM 120).

9. *Estimated Manhours.* For initial planning purposes only, it is estimated that this modification will take one manhour to perform.

10. *Stores Required.* The stores required are listed in Table 1. Modification kits are to be demanded through normal supply channels.

Detail

11. *Modification of Front Hub Breathers.* Figure 1 provides a representation of an assembled breather kit. The procedure for fitting the breather kit is as follows:

- a. Jack up front of vehicle. Support it on safety stands, and remove front wheels.
- b. Remove front bolt that secures air brake line junction block to steering arm.
- c. Fit bracket (Table 1, Item c) to top of junction block and steering arm, using existing bolts.
- d. Remove existing breather (RPS 02160, Group KC, Item 5).
- e. Screw male end of tube (Table 1, Item f) into hub, from where breather was removed.
- f. Fit nipple (Table 1, Item e) to female end of tube, and tighten.
- g. Fit nut adapter (Table 1, Item d) to nipple, with hexagonal end closest to tube.
- h. Place nut adapter through large hole in bracket with a washer (Table 1, Item b) on either side of bracket, and secure using nut (Table 1, Item a).
- i. Fit breather into nut adapter.

NOTE

The final position for tube and breather assembly is with tube (nut adapter) placed through bracket and breather facing rearward.

- j. Cable tie breather tube to front brake airline.



Ensure that tube does not rub on wheel or hub assembly.

- k. Carry out steps identified in Para 11 b to 11 j to opposite side of vehicle.
- l. Refit wheels, remove jack stands and lower vehicle.
- m. Retention wheel nuts in accordance with ref d.

12. **Recording Action.** On completion of the modification, the following action is to be taken:

- a. Deface the number 23 on the equipment modification record plate.
- b. Complete the modification details in the equipment Record Book for Service Equipment (GM 120).
- c. Forward the modification completion details to:

Fleet Manager B Vehicles
Army Materiel Management Agency
GPO Box 840J
MELBOURNE VIC 3001

- d. The return should include the following information:

- (1) Modification No: EMEI Vehicle G 797-14
- (2) Unit: eg 1 CSSB
- (3) Equipment ARN:
- (4) Completion Date:

Table 1 - Stores Required

Item	NSN	Mfr Part No	Designation or Description	Unit of Issue	Qty per Kit	Qty per Equip
1	2530 66 144 3569	67QE19401K	Kit Front Hub Breather Relocation, comprising of:	Kit	1	1
a		20AX30	Nut	ea	2	2
b		37AX189	Washer	ea	4	4
c		X50RU19401M	Bracket	ea	2	2
d		63AX531	Nut adapter	ea	2	2
e		63AX5	Nipple	ea	2	2
f		36RU171	Tube	ea	2	2

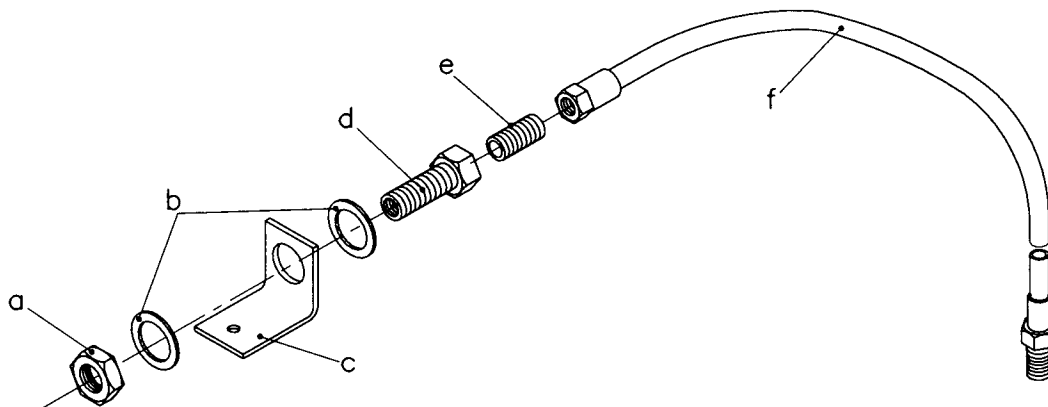

Figure 1 – Front Hub Breather Extension Tube

END

List VEH G 50.0 - Code 2 (Job No 9601649)

UNCONTROLLED WHEN PRINTED