

TRUCK, TANK WATER HEAVY, MC3 (MACK)
FITTING OF SPRAYBAR SUPPORTS

MODIFICATION INSTRUCTION

Issue of this Instruction is authorized by Army Office (TVA TH 75).

Introduction

1. This instruction details the replacement of the existing spraybar stays with an improved rigid stay.

Note:

1. NSN and Designations used in this instruction were current at the date of issue. If twelve months or more have expired since issue, the NSN should be checked for supersession.

General

2. Estimated Manhours to Perform. 3.0 (initial planning only).
3. Priority. Group 2.
4. Modification to be Applied to. All subject vehicles not modified in production.
5. Items Affected. Spraybar assembly.
6. Action Required. By RAEME units authorized to carry out unit, field and base repairs in accordance with WKSP A 850.

TABLE 1 - STORES REQUIRED (To be demanded through 11 SUP BN)

Item	Depot Stock No	Designation	Qty Per Equip
1.	2540-97-111-4908	KIT	1

TABLE 2 - STORES REQUIRED (To be demanded through normal supply channels)

Item	NSN	Designation	Qty Per Equip
1.	3439-66-013-1018	ELECTRODE WELDING MILD STEEL GP, TYPE, 3.15MM E4012 (E6012)	As Required

7. Stores to be Removed. Existing spraybar supports.

Detail

8. To carry out the modification proceed as follows:
- a. Disconnect the spraybar flexible feed pipe.
 - b. Remove the spraybar from the vehicle.
 - c. Remove the existing mounting brackets.

UNCONTROLLED WHEN PRINTED

- d. Remove the chains from the spraybar and using a grinder clean old welds from spraybar.
- e. Using mild steel welding rods from Table 2, weld the mounting lugs supplied to the spraybar as shown in Fig 1. Ensuring that the spray nozzles are horizontal and facing rearwards (Fig 2).

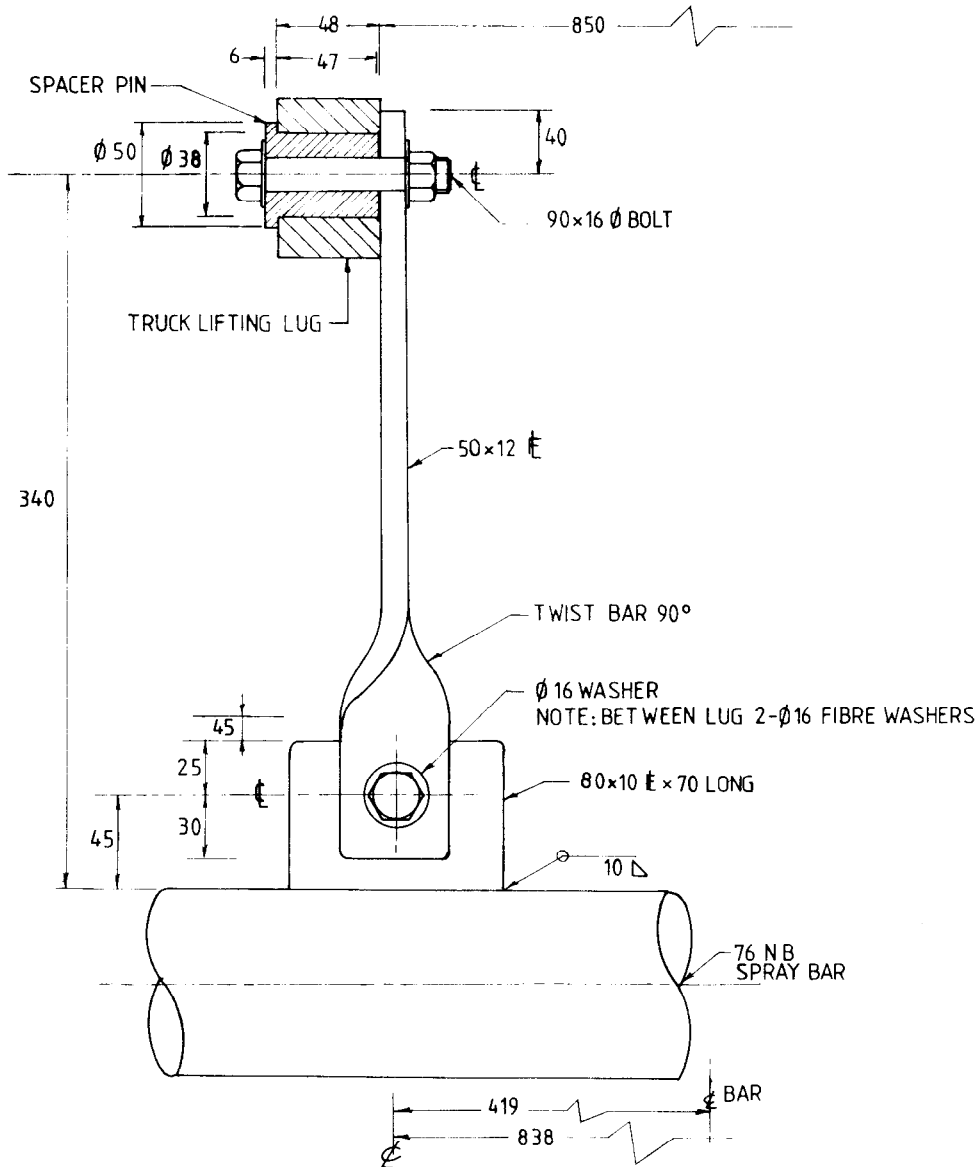

DIMENSIONS ARE IN MILLIMETRES

FIG 1 - SPRAYBAR MOUNTING DETAILS

- f. All welding is to be carried out in accordance with WKSP B 010.
- g. Assemble the hanger bars with the spacers, nuts, bolts and washers to the vehicle rear lifting lug as shown in Fig 1.

Note:

1. The spraybar hanger to vehicle lifting point bolts are to be tightened until, the nut bottoms on the flat washer against the spraybar hanger and the spacer pin Fig 1 is firmly in place. This is to allow the spraybar to pivot should it strike an object.

UNCONTROLLED WHEN PRINTED



FIG 2 - SPRAYBAR NOZZLES FACING REARWARDS

- h. Fit the spraybar to the spraybar hangers using, bolts, nuts and washers as shown in Fig 1.
- i. Refit the flexible pipe and test the operation of the spraybar.

9. Modification Record Plate. On completion of the modification, all vehicles, including those previously modified or fitted in production are to have the numeral 5 on the modification record plate defaced. The modification plate is located on the spare wheel carrier .

Documentation

10. Details of the modification are to be entered in the TGM 120 Record Book for Service Equipment of all the subject vehicles.

E N D

UNCONTROLLED WHEN PRINTED