

TRUCK, DUMP, HEAVY, MC3 (MACK)
TRUCK, DUMP, WITH WINCH, HEAVY, MC3 (MACK)
CO-AXIAL CAPACITOR - CAB HEATER BLOWER MOTOR

MODIFICATION INSTRUCTION

Issue of this instruction is authorized by COMEA

Reference: A. EMEI VEHICLE G709-1

Introduction

1. This instruction details the fitting of a co-axial capacitor to the cab heater blower motor to improve RFI suppression.

Note:

1. NSN and Designation used in this instruction were current at the date of issue. If twelve months or more have expired since issue, the NSN should be checked for supersession.

General

2. Estimated Manhours to Perform. 0.2 (initial planning only).
3. Priority. Group 2.
4. Modification to be Applied to. Trucks listed as Serials 1 to 3 in Table 6 of Reference A and ARN 36034.
5. Items Affected. Cab heater blower motor.
6. Action Required. By RAEME units authorized to carry out unit, field and base repairs in accordance with WKSP A 850.

TABLE 1 - STORES REQUIRED (To be demanded through 11 Sup Bn)

Item	Depot Stock No	Designation	Qty per Equip
1.	5910-97-111-4710	CAPACITOR, 0.5 uF (MACK Part No X70MR2184)	1

7. Stores to be Removed. Nil.

Detail

8. To carry out the modification, proceed as follows:
- Trim 10 mm off the end of the capacitor, item 1 from Table 1, mounting tail
 - Cut the power connector from the power lead and discard it.
 - Crimp suitable 3/16 inch terminal rings to the ends of the power lead, as illustrated in Fig 1, and fit the leads to the capacitor.
 - Loosen the screw on the heater body holding the earth lead and mount the capacitor as illustrated.

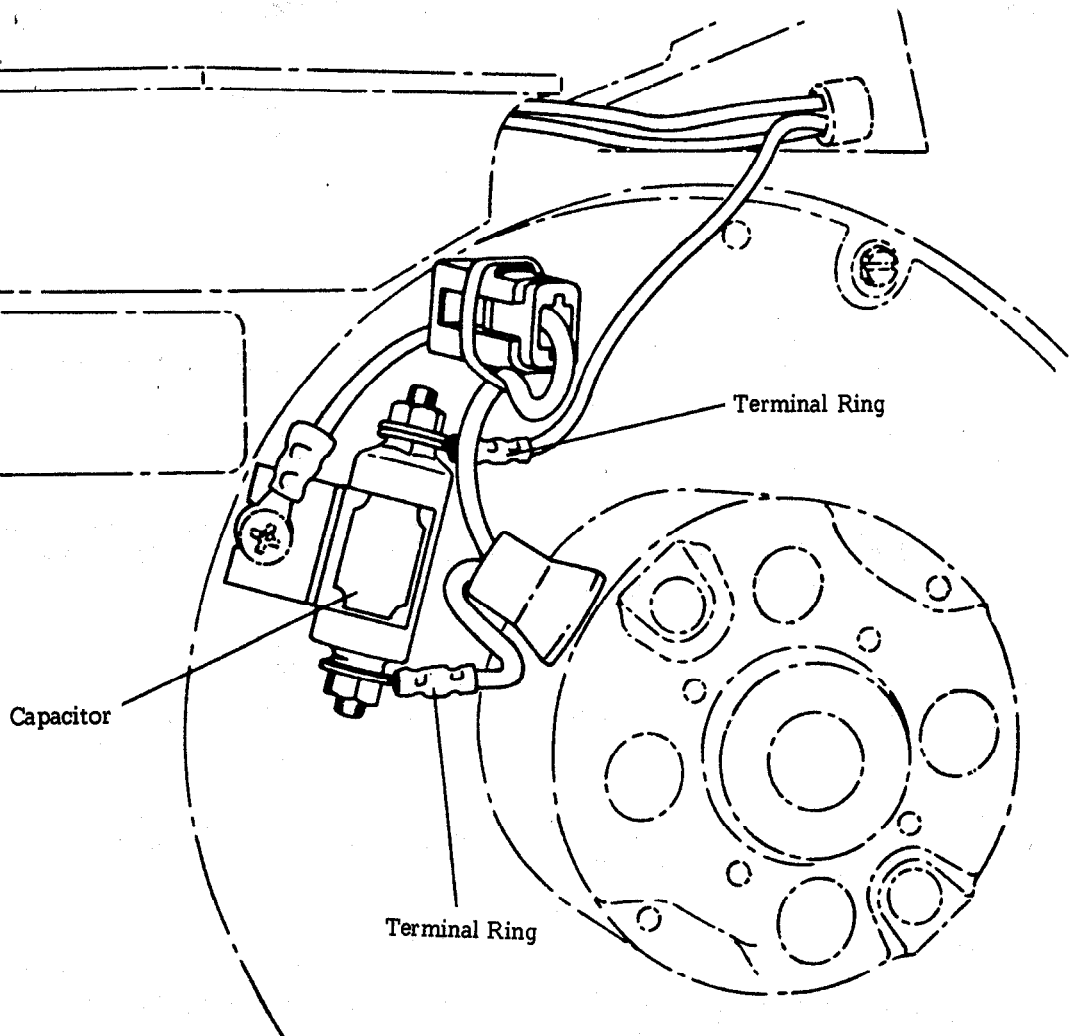

FIG 1 - MOUNTING OF CO-AXIAL CAPACITOR

Modification Record Plate

9. Deface the numeral 3 on the modification record plate mounted on the spare wheel carrier, adjacent to the operator's warning plate.

E N D

UNCONTROLLED WHEN PRINTED