

TRUCK, AMMUNITION, HEAVY, MC3 (MACK)
TRUCK, GUN TRACTOR, HEAVY, MC3 (MACK)
EXHAUST TAIL PIPE

MODIFICATION INSTRUCTION

Issue of this instruction is authorized by Army Office (B Veh TVA-TH 53).

Reference: A. EMEI VEHICLE G 799-1

Introduction

1. This EMEI replaces VEHICLE G 727-2 Issue 1 which is to be destroyed.
2. This instruction details the replacement of the straight exhaust tail pipe with a curved pipe to deflect exhaust emission rearward and eliminate the discomfort being caused to other road users.

Note:

1. NSN and Designation used in this instruction were current at the date of issue. If twelve months or more have expired since issue, the NSN should be checked for supersession.

General

3. Estimated Manhours to Perform. 0.1 (initial planning only).
4. Priority. Group 2.
5. Modification to be Applied to. Trucks listed as Serials 1 to 17 in Table 4 and Serials 2 to 16 in Table 5 of Reference A.
6. Items Affected. Exhaust tail pipe and clamp.
7. Action Required. By RAEME units authorized to carry out unit, field and base repairs in accordance with WKSP A 850.

TABLE 1 - STORES REMOVED (To be demanded through 11 Sup Bn)

Item	Depot Stock No	Designation	Qty per Equip
1.	2990-97-111-4707	PIPE TAIL, EXHAUST (MACK PT NO X5OME484)	1

TABLE 2 - STORES REMOVED (To be disposed of in accordance with GEN P series)

Item	NSN	Designation	Qty per Equip
1.	NIC	PIPE TAIL, EXHAUST (MACK PT NO X5OME364A)	1

Detail

8. To carry out the modification, proceed as follows:
 - a. Loosen the clamp, item 1 in Fig 1 and remove the exhaust tail pipe, item 2.
 - b. Using the original clamp, item 1 in Figs 1 and 2, fit the new exhaust tail pipe, item 1 from Table 1 as shown in Fig 2. Ensure the tail pipe is facing rearward and slightly downward and tighten the clamp.

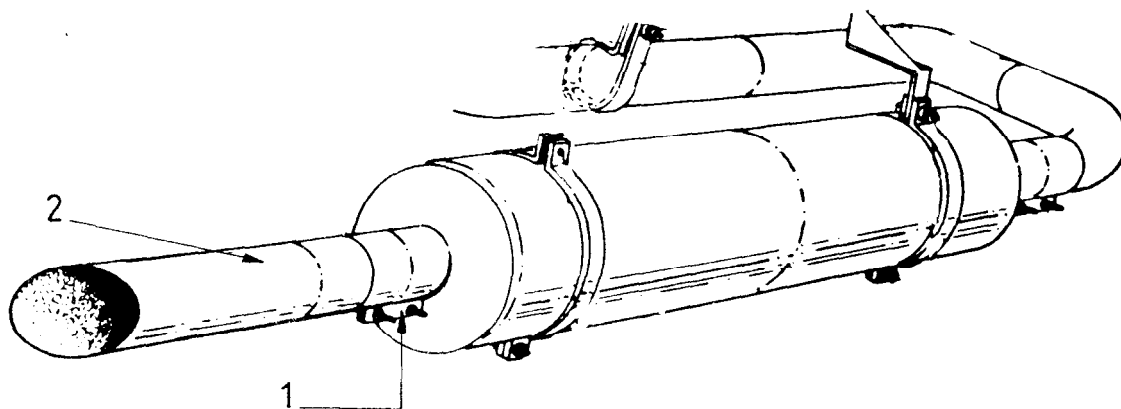

FIG 1 - STRAIGHT EXHAUST TAIL PIPE

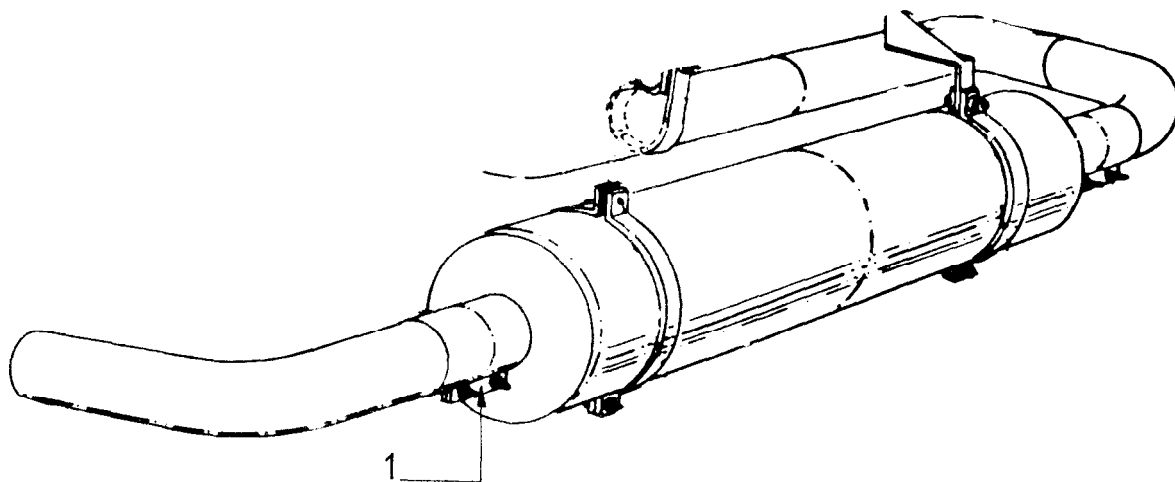

FIG 2 - CURVED EXHAUST TAIL PIPE

Modification Record Plate

8. Deface the numeral 2 on the modification record plate of all vehicles including, those modified in production. The modification record plate is mounted on the spare wheel carrier, adjacent to the operators warning plate.

Documentation

10. Details of the modification are to be entered in the TGM 120, Record Book for Service Equipment of the vehicle.

E N D

UNCONTROLLED WHEN PRINTED