

## TRUCK, GUN TRACTOR/AMMO TRANSPORTER, HEAVY, MC3, MACK

### HIAB 090 CRANE PTO TAIL FITTING AND HOSE SUPPORT BRACKET

## MODIFICATION INSTRUCTION

This instruction is authorised for use by command of the Chief of Army. It provides direction, mandatory controls and procedures for the operation, maintenance and support of equipment. Personnel are to carry out any action required by this instruction in accordance with EMEI General A 001.

### INTRODUCTION

1. This instruction details the replacement of the PTO pump tail fitting with a more robust fitting and the installation of a hose support bracket.
2. **Associated Publications.** Reference may be necessary to the latest issue of the following documents:
  - a. Technical Regulation of Army Materiel Manual (TRAMM) (available from DTR-A website <http://intranet.defence.gov.au/armyweb/Sites/DTRA>);
  - b. TRAMM, Volume 3, Section 2, Chapter 2, Fleet Engineering Change Management Process; and
  - c. Defence Supply Chain Manual (DSCM), Volume 4, Section 3 – Supply Management Processes, Stores Accounting General (DSCM website <http://dknl009.car.defence.gov.au/dscm/index.htm>).
3. **Authority.** ECO MHB 008/04 is the authority to carry out this modification.

### GENERAL

4. **Modification Application.** This modification is to be applied to Mack Gun Tractor/Ammo Transporter Vehicles.
5. **Items Affected.** This modification alters the hydraulic PTO pump.
6. **Priority – Group 2.** All applicable equipment is to be modified:
  - a. when next in a workshop for Light, Medium or Heavy Repair; or
  - b. prior to issue from depot or pool stock.

#### NOTE

Where modification would delay priority issues of depot or pool stock, equipment may be issued unmodified providing the equipment record book is endorsed appropriately.

7. **Action Required.** Actions detailed in this instruction are to be performed by technical maintenance organisations authorised to carry out Light, Medium or Heavy Grade Repairs, utilising technicians ECN 229 or civilian equivalents authorised to carry out Light, Medium or Heavy Repairs.

#### NOTE

On receipt of this instruction, enter all relevant information other than date completed in the modifications section of the GM 120 Record Book for Service Equipment.

8. **Estimated Workhours.** For initial planning purposes only, it is estimated that this modification will take two workhours to perform.
9. **Stores Required.** The stores required are listed in Table 1. All stores are to be demanded through normal supply channels.
10. **Items to be Removed.** The items to be removed are listed in Table 2. All stores removed are to be processed in accordance with the DSCM.

**DETAIL**

**11. Replacement of PTO Hydraulic Tail Fitting.** The procedure is as follows:

- a. Close supply valve located beneath the reservoir (see Figure 1).



**Figure 1 Supply Valve in Closed Position**

- b. Place suitable receptacle to catch oil (approx 2 L), which will drain from the disconnected hose beneath the PTO pump.
- c. Cut cable ties, if fitted.

**NOTE**

The “bash plate” may be removed for ease of access.

- d. Loosen hose clamp at the 90 degree elbow tail fitting and remove hydraulic hose from fitting.
- e. Drain hydraulic oil from the hose.
- f. Loosen jamnut on the tail fitting.
- g. Remove fitting from PTO pump by spinning off.
- h. Remove O ring from fitting and save.
- i. Remove jamnut from fitting and save.

**NOTE**

If either the jamnut or O ring is damaged, the damaged item is to be discarded and replaced.

- j. Discard the removed 90 degree elbow fitting.
- k. Clean O ring, jamnut and female connection on PTO pump.
- l. Screw jamnut onto new fitting winding all the way on (see Figure 2).

**NOTE**

Ensure flat side of jamnut faces towards body of new fitting (see Figure 2).

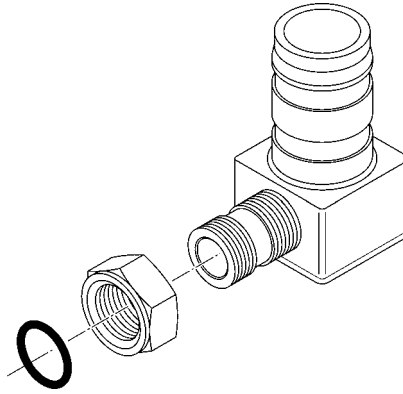
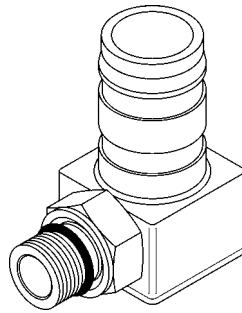

**Figure 2 Jamnut Fitting**

- m. Fit O ring onto new fitting (see Figure 3).

**NOTE**

Ensure the O ring is located centrally in the recess of the boss (see Figure 3).



**Figure 3 O Ring Location**

- n. Apply a light coating of Loctite 569 (hydraulic sealant) to the thread of the new fitting.
- o. Screw fitting into the input side of the PTO pump until the O ring mates with the PTO pump.

**NOTE**

Ensure fitting is facing downwards to the rear at an angle of approximately 45 degrees (see Figure 4).

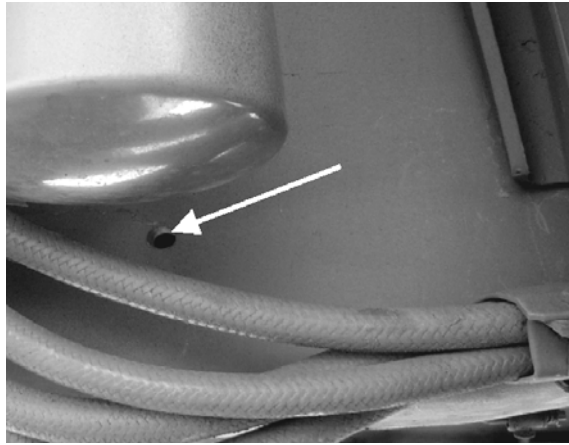

**Figure 4 Tail Fitting Alignment**

- p. Secure the jamnut.
- q. Replace hydraulic hose on to the new tail fitting and tighten the hose clamp.

**12. Hose Support Clamp Fitting**

- a. Insert 1½ by 3/8 inch UNF bolt (fitted with washer) through hole in chassis rail, behind primary fuel filter (see Figure 5).



**Figure 5 Location of Hole for Hose Bracket Fitting**

**NOTE**

Ensure the thread of the bolt faces outwards (see Figure 6).

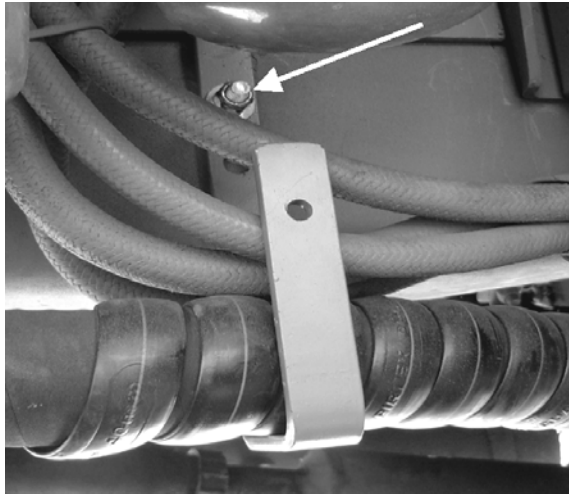

**Figure 6 Bolt Alignment**

- b. Place bracket over bolt (see note below).

**NOTE**

Either hole may be used to mount the bracket, ensuring as much hose slack is taken up as possible.

- c. Secure the bracket with washer and Nyloc nut.

**NOTE**

It may be necessary to remove the primary fuel filter to gain sufficient access to secure the nut.

- d. Route cable tie through hole in bracket and secure fuel lines and hydraulic hoses (see Figure 7).

UNCONTROLLED WHEN PRINTED

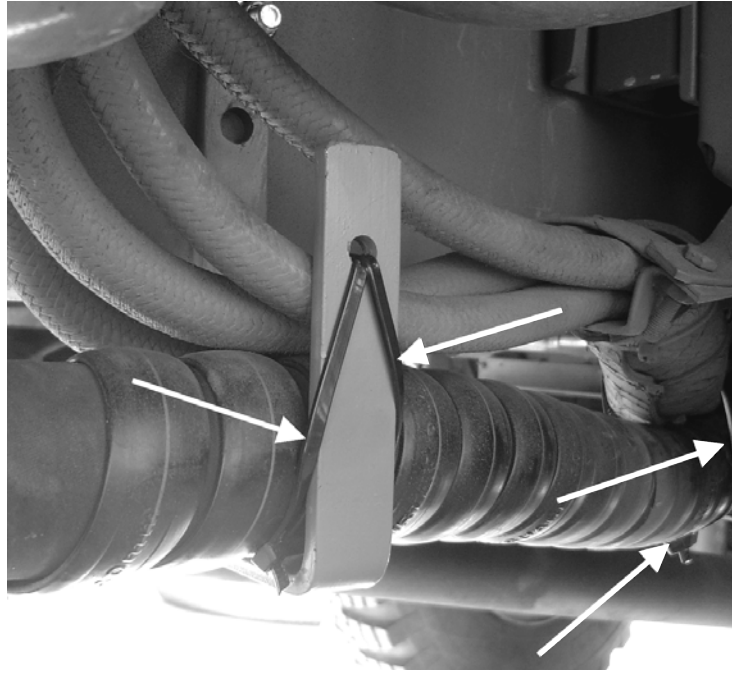

**Figure 7 Securing Fuel Lines and Hydraulic Hoses**

- e. Apply cable ties to hydraulic hoses as necessary (see Figure 7).
- f. Replace bash guard and primary fuel filter (if removed).
- g. Open supply valve.
- h. Check for any leaks.
- i. Check hydraulic oil level (top up if required).

**13. Recording Action.** On completion of the modification, the following action is to be taken in accordance with TRAMM, Volume 3, Section 2, Chapter 2, Annex D:

- a. deface the number #45 on the modification record plate;
- b. complete the modification details in the GM 120 – Record Book for Service Equipment; and
- c. forward the modification completion details using form GM 119 – Advice of Change in Build State (TRAMM, Volume 3, Section 2, Chapter 3, Annex C) to:

WO2 Tech Adviser Mack  
Mdm/Hvy B Vehicles  
LV SPO, DMO  
Victoria Barracks, St Kilda Rd  
SOUTHBANK VIC 3006

**Table 1 Stores Required**

Item	NSN	Supplier Part No	Designation or Description	Unit of Issue	Qty per Kit	Qty per Equip
1	4320-66-152-4600	40QE39413M	Connector, Fluid, Pump, Adaptor Hose Assembly, Power Take Off, Mack, MC3	ea	N/A	1
2	4320-66-152-4601	29QE49412M	Bracket Mounting Hose, Power Take Off Pump, Mack, MC3	ea	N/A	1
3	5360-66-122-5630		Bolt, Machine, $\frac{3}{8}$ inch, 24 TPI, UNF, $1\frac{1}{2}$ inch lg, High Tensile	ea	N/A	1
4	5310-00-087-7493		Washer, Flat RD, Steel, Cad Plated W/Chromate, 0.380 inch ID, 0.905 inch OD, 0.104 inch thk	ea	N/A	2
5	5310-66-018-2087		Nut, Self-Locking, Hexagon UNF, 2B, P Steel, Type T, Cad Plated, $\frac{3}{8}$ inch, W/Nylon Insert	ea	N/A	1
6	8030-66-049-6180	Loctite 569	Sealing Compound Retain Metal Parts, Grade Hydraulic Sealant, Medium Strength, Brown 50 mL	as req'd	N/A	as req'd
7			Jamnut (Note 1)	ea	N/A	1 (if req'd)
8			O Ring (Note 1)	ea	N/A	1 (if req'd)
<p>Note 1: If the jamnut or O ring require replacing, order the Elbow, 90 Deg Assembly, P/No. HIABHTPR34P112, and discard unwanted items.</p>						

**Table 2 Items to be Removed**

Item	NSN	Supplier Part No	Designation or Description	Qty per Equip
1	NIC	HIABHTPR34P112	Elbow, 90 degree, Suction Hose Tail, $1\frac{1}{2}$ inch lg, 38 mm OD by $\frac{3}{4}$ inch BSPP	1

**END**  
Distribution List: **VEH G 53.0 – Code 2** (Maint Code)  
(Sponsor: LV SPO, Med/Hvy B Vehicles)

UNCONTROLLED WHEN PRINTED