

TRUCK, CARGO, WITH CRANE, HEAVY, MC3 (MACK)

ALTERATIONS TO AIR CLEANER MOUNTING

## MODIFICATION INSTRUCTION

Issue of this instruction is authorized by CONMEA

Reference: A. EMEI VEHICLE G 709-1

Introduction

1. This instruction details the operations necessary to relocate engine air cleaners in order to reduce the truck width to the legal limit of 2.5 m.

## Note:

1. NSN and Designation used in this instruction were current at the date of issue. If twelve months or more have expired since issue, the NSN should be checked for supersession.

General

2. Estimated Manhours to Perform. 3.2 (initial planning only).
3. Priority. Group 2.
4. Modification to be Applied to. Trucks listed as Serials 1 to 33 in Table 3 of Reference A.
5. Items Affected. Engine air cleaners, RH mudguard and bonnet.
6. Action Required. By RAEME units authorized to carry out unit, field and base repairs in accordance with WKSP A 850.

TABLE 1 - STORES REQUIRED (To be demanded through 11 Sup Bn)

Item	Depot Stock No	Designation	Qty per Equip
1.		KIT MODIFICATION, COMPRISING:	1
2.	5340-97-111-4708	CLAMP, AIR CLEANER, RIGHT HAND SIDE (MACK PART NO X50MD371)	2
3.	5340-97-111-4709	BRACKET, AIR CLEANER MOUNTING (MACK PART NO X50MD469A)	1

TABLE 2 - STORES REMOVED (To be returned to 11 Sup Bn for bulk return to MACK AUSTRALIA Pty Ltd)

Item	NSN	Designation	Qty per Equip
1.	NIC	BRACKET, AIR CLEANER (MACK PART NO X50MD469)	1

Detail

7. To carry out the modification, proceed as follows:

- a. Right hand air cleaner. Referring to Fig 1, remove existing air cleaner straps and replace with item 2 from Table 1.

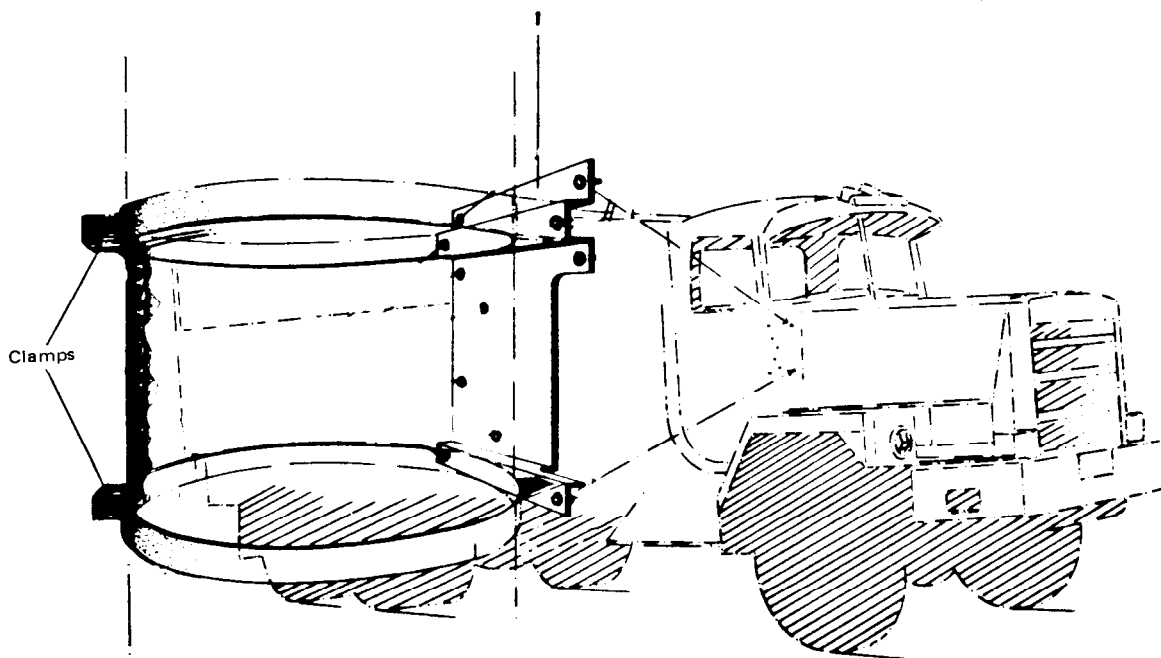

FIG 1 - RIGHT HAND AIR CLEANER

b. Left hand air cleaner:

- (1) Remove the air intake, air cleaner clamps, air cleaner and mounting brackets.
- (2) Referring to Fig 2, remove metal from the rear of the panel indicated as shown in Fig 3.
- (3) Dress the reworked area and paint in accordance with WKSP B 700.
- (4) Using a full size template, mark the bonnet panel and cut out the required area.

Note:

1. Templates will be supplied on application to Maintenance Engineering Agency, 350 St Kilda Road, Melbourne 3004.
- (5) Dress the reworked area and paint in accordance with WKSP B 700.
- (6) Replace the existing air cleaner mounting bracket with item 3 from Table 1.
- (7) Referring to Fig 4, fit the air cleaner and clamps using the inner set of holes and ensuring that the pinch bolt lugs are oriented towards the bonnet by mounting them in the reverse direction.

CAUTION:

1. During assembly, ensure that air cleaner piping is free from dust, dirt and any foreign bodies.
2. All intake piping is to be correctly fitted and tightened.
3. No fouling conditions are permitted.
4. All air cleaner clamps and brackets must be tight.

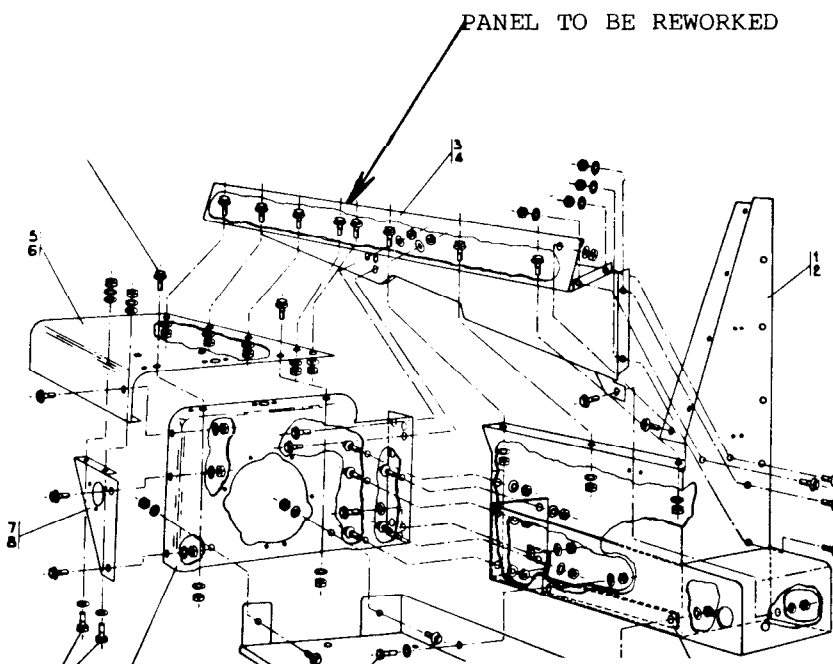

FIG 2 - MUDGUARD ASSEMBLY - PANEL TO BE REWORKED

UNCONTROLLED WHEN PRINTED

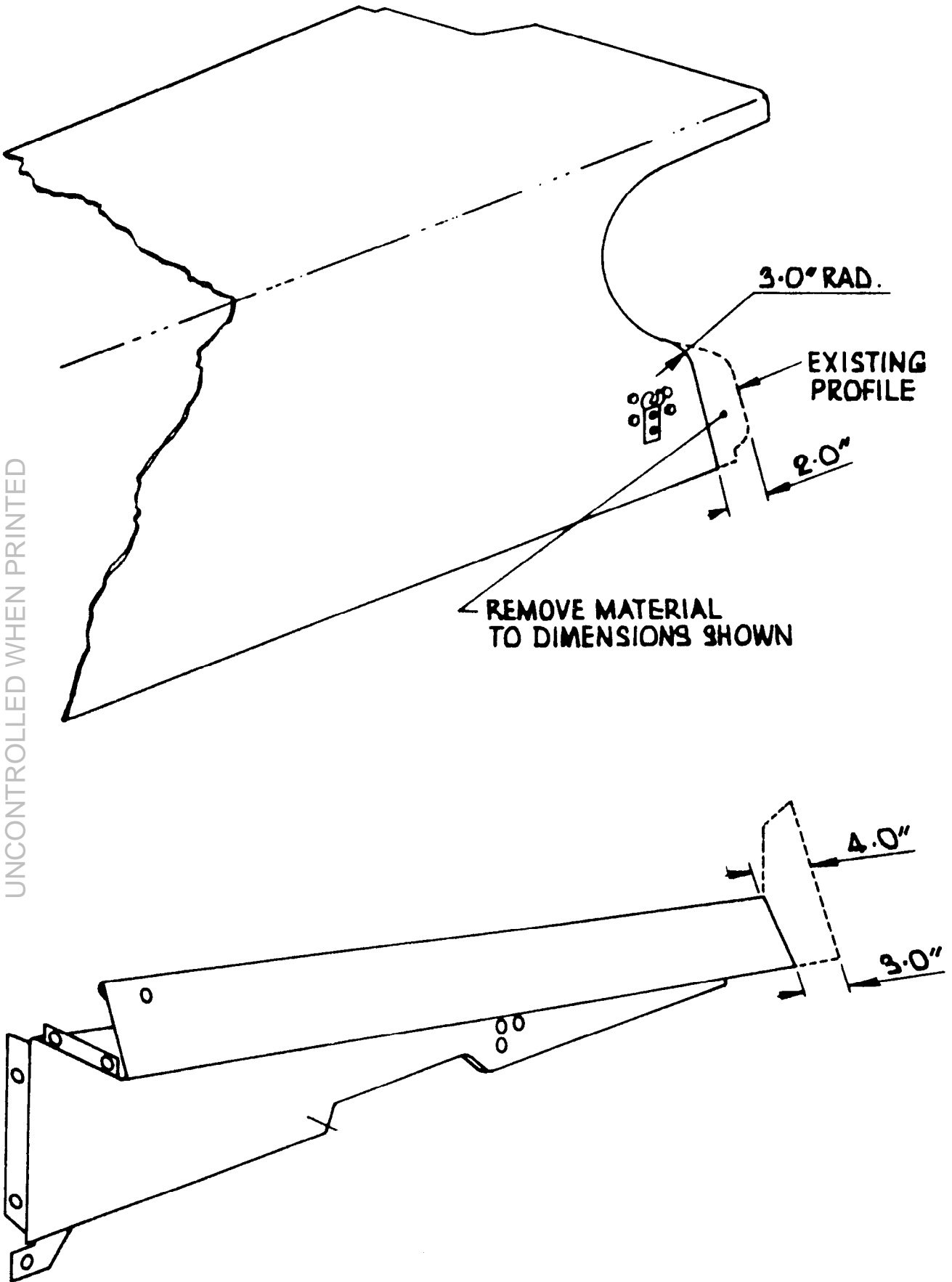

FIG 3 - CUT-AWAY PORTION OF MUDGUARD PANEL

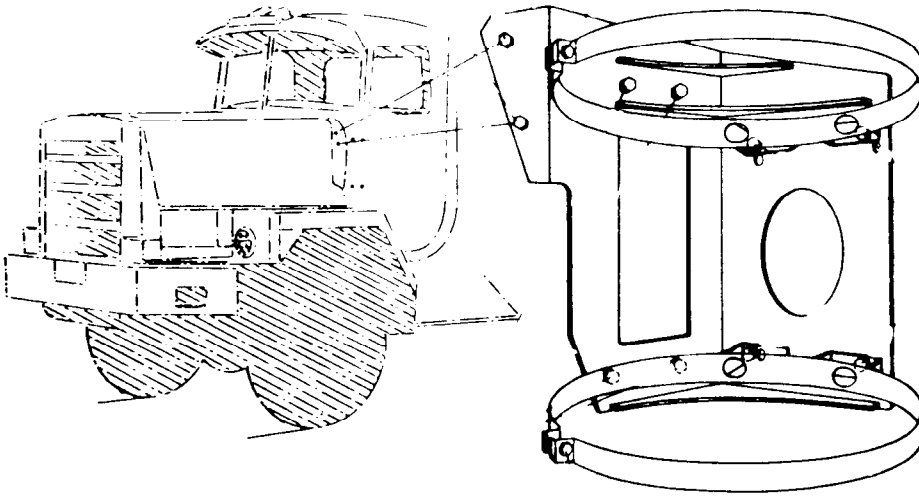

FIG 4 - FITTING OF LEFT HAND AIR CLEANER

Modification Record Plate

8. Deface the numeral 6 on the modification record plate mounted on the spare wheel carrier arm, adjacent to the operator's warning plate.

E N D

UNCONTROLLED WHEN PRINTED