

TRUCK, CARGO, WITH CRANE, HEAVY, MC3 (MACK)
ADDITIONAL FRONT MUDDLAPS

MODIFICATION INSTRUCTION

Issue of this instruction is authorized by CONMEA

Reference: A. EMEI VEHICLE G 709-1

Introduction

1. This instruction details the fitting of additional front mud flaps to increase the effective length and reduce mud spatter on components and CES items.

Note:

1. NSN and Designation used in this instruction were current at the date of issue. If twelve months or more have expired since issue, the NSN should be checked for supersession.

General

2. Estimated Manhours to Perform. 2.0 (initial planning only).
3. Priority. Group 2.
4. Modification to be Applied to. Trucks listed as Serials 1 to 43 in Table 3 of Reference A.
5. Items Affected. Front mudflaps.
6. Action Required. By RAEME units authorized to carry out unit, field and base repairs in accordance with WKSP A 850.

TABLE 1 - STORES REQUIRED (To be demanded through 11 Sup Bn)

Item	Depot Stock No	Designation	Qty per Equip
1.		KIT MODIFICATION, FRONT MUD FLAP, COMPRISING:	1
2.	2520-97-111-4715	MUDDLAP (MACK PART NO X50QM315B)	2
3.	5120-97-111-4716	BAR CLAMPING (MACK PART NO X50QM211C)	4
4.	5330-97-111-4717	WASHER FLAT (MACK PART NO 37AX68)	12
5.	5306-97-111-4718	BOLT (MACK PART NO 1AX189)	4
6.	5306-97-111-4719	BOLT (MACK PART NO 1AX400)	4
7.	5306-97-111-4720	LOCKNUT (MACK PART NO 21AX314)	8
8.	5306-97-111-4721	SPACER (MACK PART NO 35AX35B)	4

7. Stores to be Removed. Nil.

Detail

8. To carry out the modification, proceed as follows:
- Remove the existing front mudflaps.
 - Using mudflaps, item 2 from Table 1, as templates, drill the existing mudflaps to suit.
 - Using the existing holes in the front face of the steps as reference points (see Fig 1), drill two holes 0.34 inch diameter, using clamping bars, item 3 from Table 1, as templates.
 - Assemble the new mudflaps, item 2 from Table 1, to the old ones, using clamping bars, item 3 from Table 1, and two bolts, two flat washers and two locknuts, items 6, 4 and 7 from Table 1, ensuring that the bolts are fitted into the outer pairs of holes.
 - Re-assemble the existing mudflap to the mudguard using the existing bolts, washers and nuts.
 - Using the spacers, item 8 from Table 1, between the clamping bars and the step (see Fig 1), secure the mudflap to the step using two bolts, four flat washers and two locknuts, items 5, 4 and 7 from Table 1.

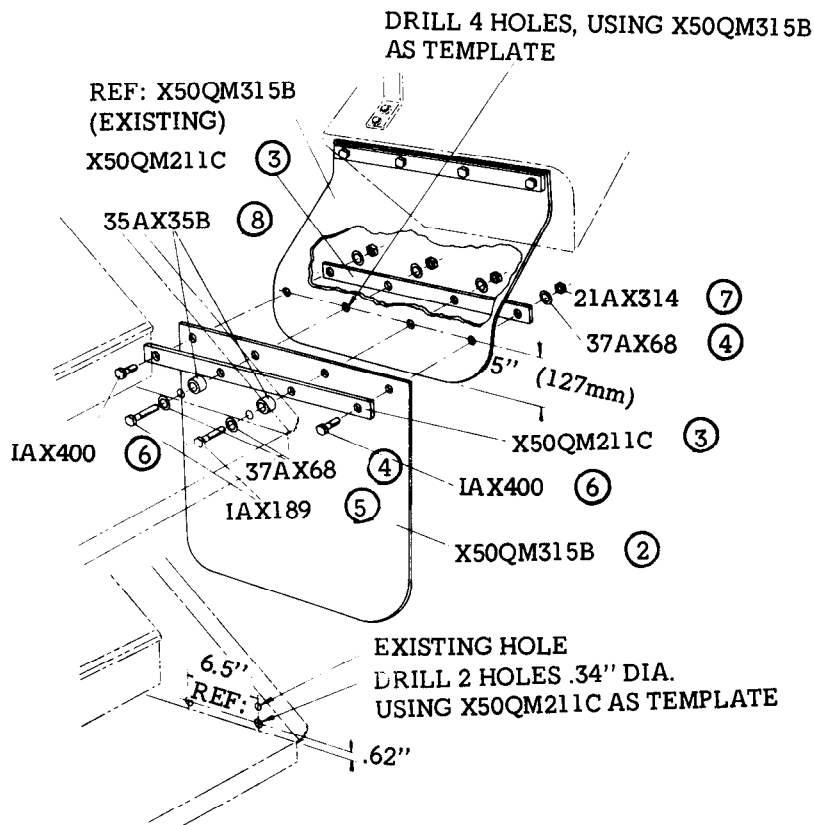

FIG 1 - FITTING DETAILS FOR ADDITIONAL MUDFLAP

Modification Record Plate

9. Deface the numeral 3 on the modification record plate mounted on the spare wheel carrier, adjacent to the operators warning plate.

E N D

UNCONTROLLED WHEN PRINTED