

TRUCK CARGO, HEAVY, MC3 (MACK), TRUCK CARGO, WITH WINCH HEAVY
STRENGTHENING OF BATTERY BOX MOUNTS

MODIFICATION INSTRUCTION

Reference: A. AC in WM 30348/4 30349/4 30777/3 and 30778/3

Introduction

1. This instruction details the modification of the battery box supporting brackets and the fitting of a new battery clamp.

Note:

1. NSN and Designation used in this instruction were current at the date of issue. If twelve months or more have expired since issue, the NSN should be checked for supersession.

General

2. Estimated Manhours to Perform. 4.0 hrs (initial planning only).
3. Priority. Group 2. To be undertaken during next field repair or when cracks are found in the lower battery box.
4. Modification to be Applied to. All subject vehicles.
5. Items Affected. The lower battery box, battery box mounts and the battery clamp.
6. Action Required. By RAEME units authorized to carry out field and base repair in accordance with WKSP A 850.
7. Stores Required. Table 1 contains a list of stores required for this modification.

TABLE 1 - STORES REQUIRED (To be demanded through normal channels)

Serial	NSN	Designation	Qty Required
1.	5305-66-019-3678	SCREW, MACHINE, UNF, HEX HD, 3/8 INCH BY 3/4 INCH LG	2
2.	5305-66-019-3680	SCREW, MACHINE, UNF, HEX HD, 3/8 INCH BY 1 INCH LG	2
3.	5310-66-019-3958	NUT, PLAIN, HEX, UNF 3/8 INCH	4
4.	5310-66-016-5991	WASHER, LOCK, SPRING, STEEL, 5/8 INCH BOLT SIZE	6
5.	5310-66-016-5996	WASHER, LOCK, SPRING, STEEL, 3/8 INCH BOLT SIZE	4
6.	5310-66-016-8930	WASHER, FLAT, ROUND, 3/8 INCH BOLT SIZE	8
7.	9520-66-097-0456	STEEL, ANGLE, CARBON, 25 BY 25 BY 5MM	As Required
8.	9520-66-097-0465	STEEL, ANGLE, CARBON, 51 BY 51 BY 6.5MM	As Required
9.	8010-66-010-4687	PRIMER, COATING, METAL, RED OXIDE, 1 LITRE	As Required
10.	8010-66-025-5001	ENAMEL, LUSTRELESS, OLIVE DRAB, 1 LITRE	As Required

8. Stores Removed. Table 2 contains a list of those stores removed as a result of this modification.

TABLE 2 - STORES REMOVED (To be disposed of in accordance with GEN P Series)

Serial	NSN	Designation	Qty Removed
1.	5310-01-147-9617	NUT HEX HD 5/16 INCH	4
2.	5310-01-161-2129	NUT, SPRING, PUSH ON TYPE	2
3.	5310-66-122-7199	BOLT SPECIAL 5/16 INCH	2
4.	5316-00-023-3524	WASHER LOCK	2
5.	5310-NIC	BOLT, HEX HD, 5/8 INCH, 18 UNF, 2 INCH LG	2
6.	6140-NIC	BRACKET BATTERY HOLD DOWN	1

Detail

9. Remove the battery box and its brackets from the vehicle chassis as follows:

- a. Remove the battery box cover.
- b. Disconnect battery leads and battery bridge.
- c. Remove battery clamp and remove the batteries.
- d. Remove the 4 x 5/8 inch UNF bolts securing the battery box to the chassis brackets and remove the battery box lower.
- e. Mark the top and outer faces of the chassis brackets for future reference.
- f. Unscrew the 4 x 5/8 inch UNF bolts and nuts securing the brackets to the chassis and remove the bracket.

10. Modify the chassis mounting brackets as follows:

- a. Cut the brackets to an overall length of 254mm (10 inch) measured from the top of the bracket.
- b. Modify the bracket as per Fig 1.

11. Modify the battery box lower as per Fig 2.

12. Should the battery box lower be cracked, repair by stop drilling, veeing and welding the crack/s.

13. Manufacture new battery clamps as per Fig 3.

14. Paint all new work in accordance with WKSP B 700.

15. Fit the modified battery box, chassis mounting brackets and battery clamp as follows:

- a. To fit the modified chassis bracket, first place a 5/8 inch UNF bolt in the new work 18 mm diameter hole from inside the channel and retain in place with a nut, then fit the bracket to the vehicle chassis using the original 5/8 inch bolts and nuts (fit new lock washers).

UNCONTROLLED WHEN PRINTED

- b. Remove the nuts used to retain the 5/8 inch diameter bolts in the new work, place the battery box on to the bracket, - check hole alignment and battery box fit (rework brackets if holes do not align or battery box does not fit correctly).
 - c. Retain battery box in place using the 5/8 inch diameter bolts, washers and nuts, (use new lock washers), fit the rear battery clamp as per Fig 4 and secure in place using items 1, 3, 4 and 5 of Table 1, tighten the 5/8 inch diameter nuts and bolts.
 - d. Place batteries into battery box (end on and side by side), secure with front battery clamp using items 2, 3, 4 and 5 of Table 1.
 - e. Fit battery bridge to terminals closest to vehicle chassis, connect battery leads, check electrical conductivity and fit battery box cover.
16. Deface the number 16 on the modification record plate.

UNCONTROLLED WHEN PRINTED

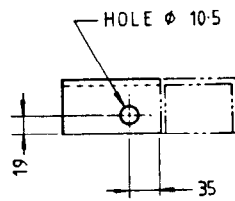

NEW WORK IN FULL LINE
EXISTING WORK IN CHAIN LINE
DIMENSIONS ARE IN mm

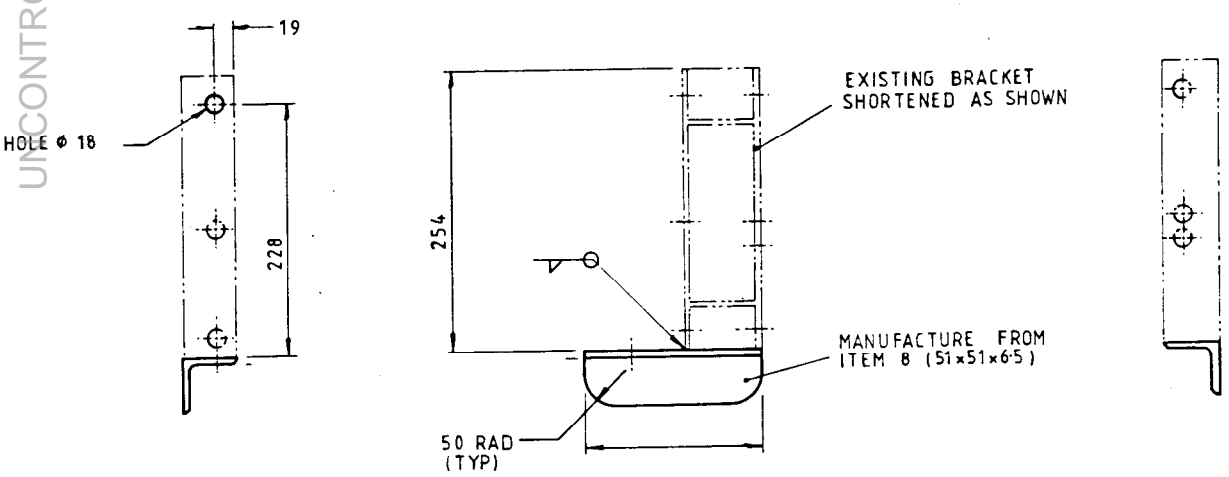

FIG 1 - CHASSIS SUPPORT BRACKET

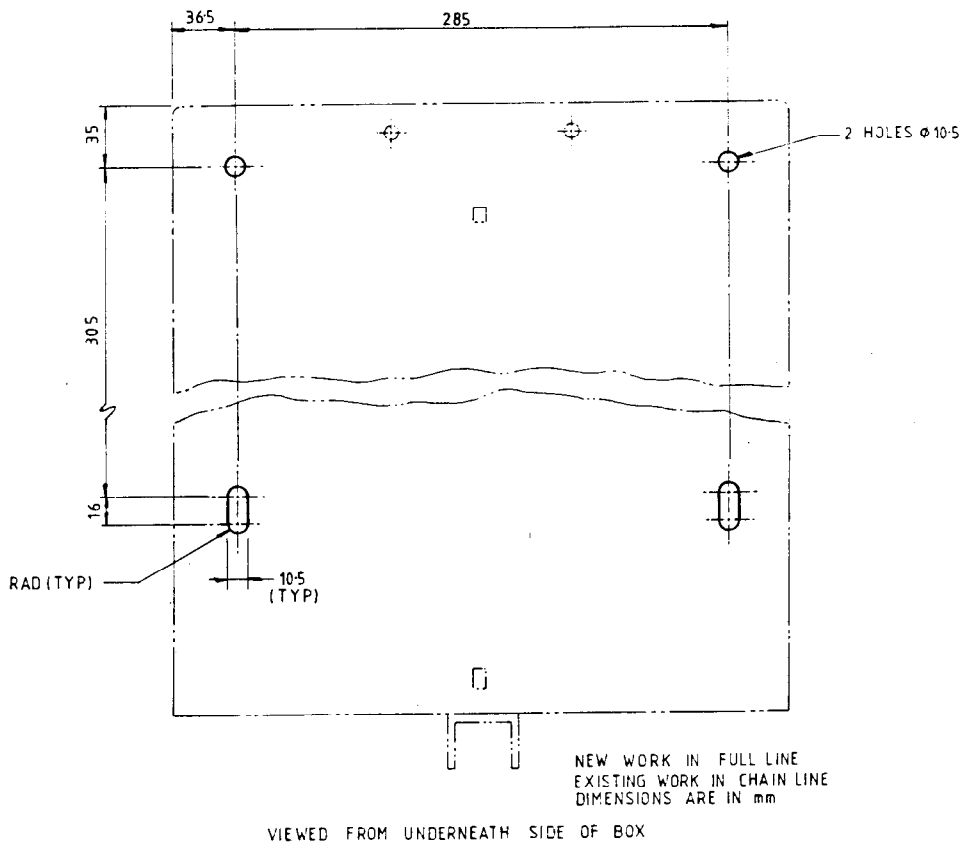

FIG 2 - BASE OF BATTERY BOX LOWER

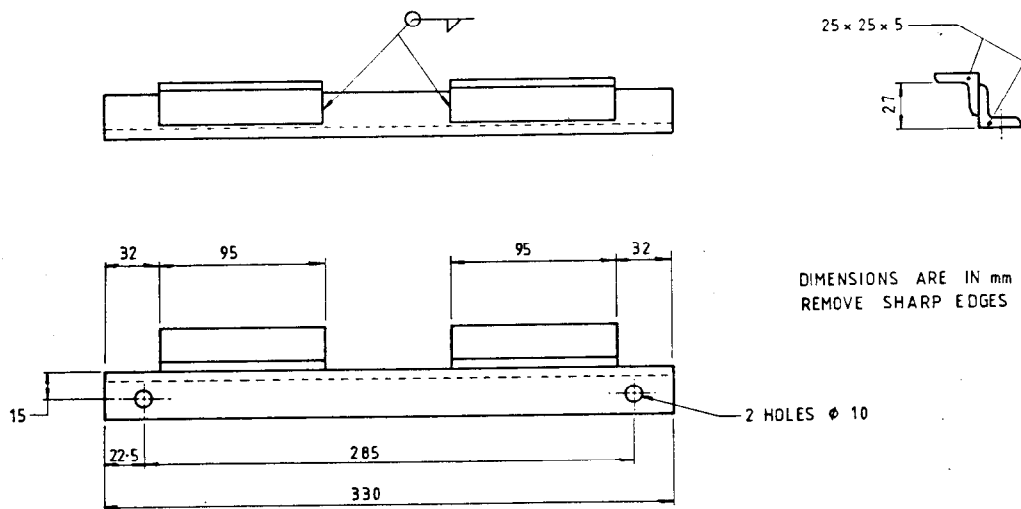

FIG 3 - NEW BATTERY CLAMPS

UNCONTROLLED WHEN PRINTED

UNCONTROLLED WHEN PRINTED

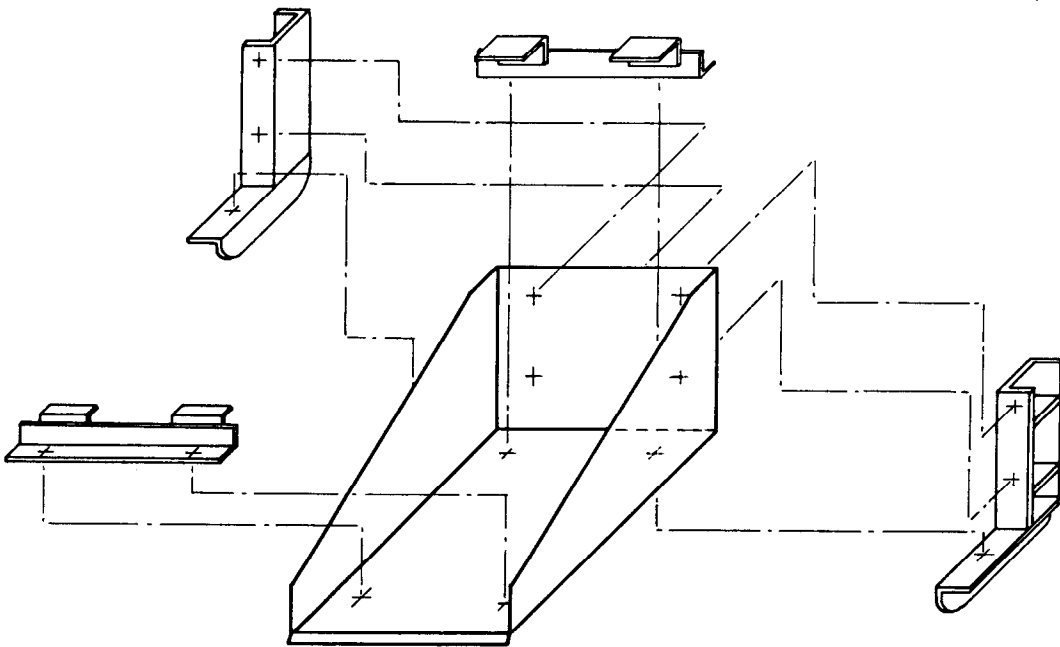

FIG 4 - ASSEMBLY OF BATTERY BOX LOWER, CHASSIS BRACKETS
AND BATTERY CLAMP

E N D