

UNIMOG TRUCKS (ALL TYPES)

FITTING OF AUSTSTEYR WEAPON BRACKETS

MODIFICATION INSTRUCTION

This EMEI is authorised for issue by the CGS. It provides direction, mandatory controls and procedures for the operation, maintenance and support of equipment. Personnel are to obey the instructions and follow the procedures contained in this publication.

Introduction

1. This instruction details the modification to the existing 'SLR' brackets, and the fitting of the new AUSTSTEYR Weapon clips and brackets (Fig 1).

Note:

1. NSN and Designation used in this instruction were current at the date of issue. If twelve months or more have expired since issue, the NSN should be checked for supersession.

General

2. Estimated Manhours Required. 2.0 hrs (initial planning only).
3. Priority. Group 2.
4. Modification Application. All subject vehicles.
5. Items Affected. SLR Weapons Brackets.
6. Action Required. By Unit, Field and Base Workshops only in accordance with EMEI WKSP A 850.

TABLE 1 - STORES REQUIRED

Item	NSN	Designation	Qty per Equip
1.	2540-66-128-5990	VEHICLE WEAPON RACK	2 Kits

Note:

1. Item 1 is to be demanded by signal to Logistic Command (MECH Group).

TABLE 2 - ADDITIONAL STORES

Item	NSN	Designation	Qty per Equip
1.	9515-66-097-0446	METAL BAR, CARBON STEEL 25MM X 3MM THK	As Required
2.	5305-66-098-4349	MACHINE SCREW AND NUT 5MM X 20MM LONG	4
3.	5310-66-098-4427	WASHER SPRING	4

UNCONTROLLED WHEN PRINTED

7. Stores Removed. The 'SLR' rifle clip and butt box are to be removed and disposed of in accordance with current instructions.

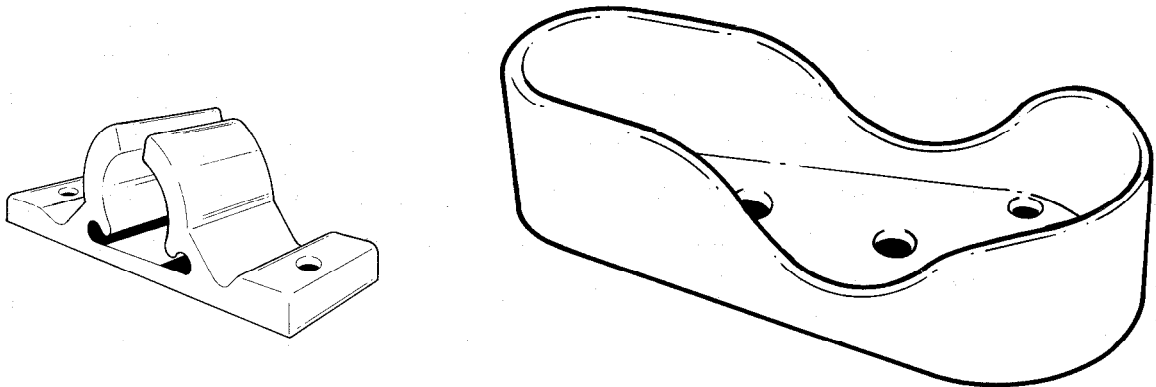

FIG 1 - AUSTSTWEYR RIFLE CLIP AND BUTT BOX

Detail

8. Remove the 'L' shaped bracket with the rifle clip intact. Separate the rifle clip and bracket, and retain the nuts and bolts. Reverse the 'L' shaped bracket and re-install in the original position as shown in Fig 2.
9. Remove the 'SLR' butt box and retain the three screws and spring washers.

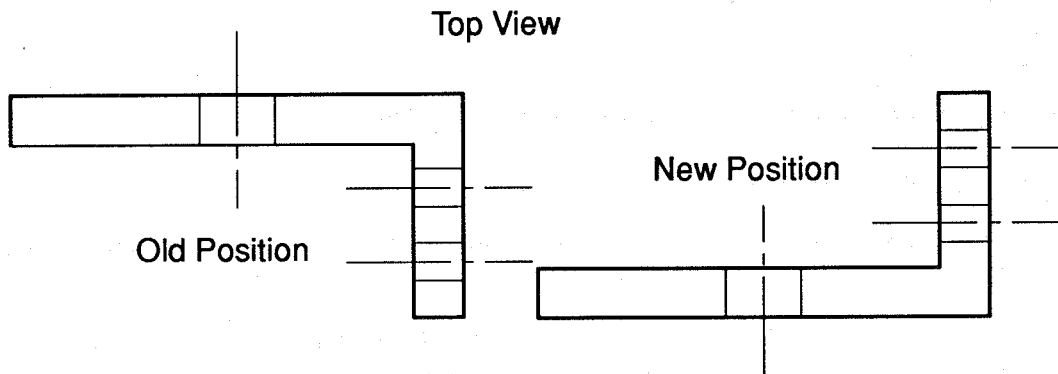

FIG 2 - POSITION OF L SHAPED BRACKET

UNCONTROLLED WHEN PRINTED

10. Manufacture AUSTSTEYR Rifle Clip Retaining Bracket using Item 1, Table 2 to the dimensions shown in Fig 3.

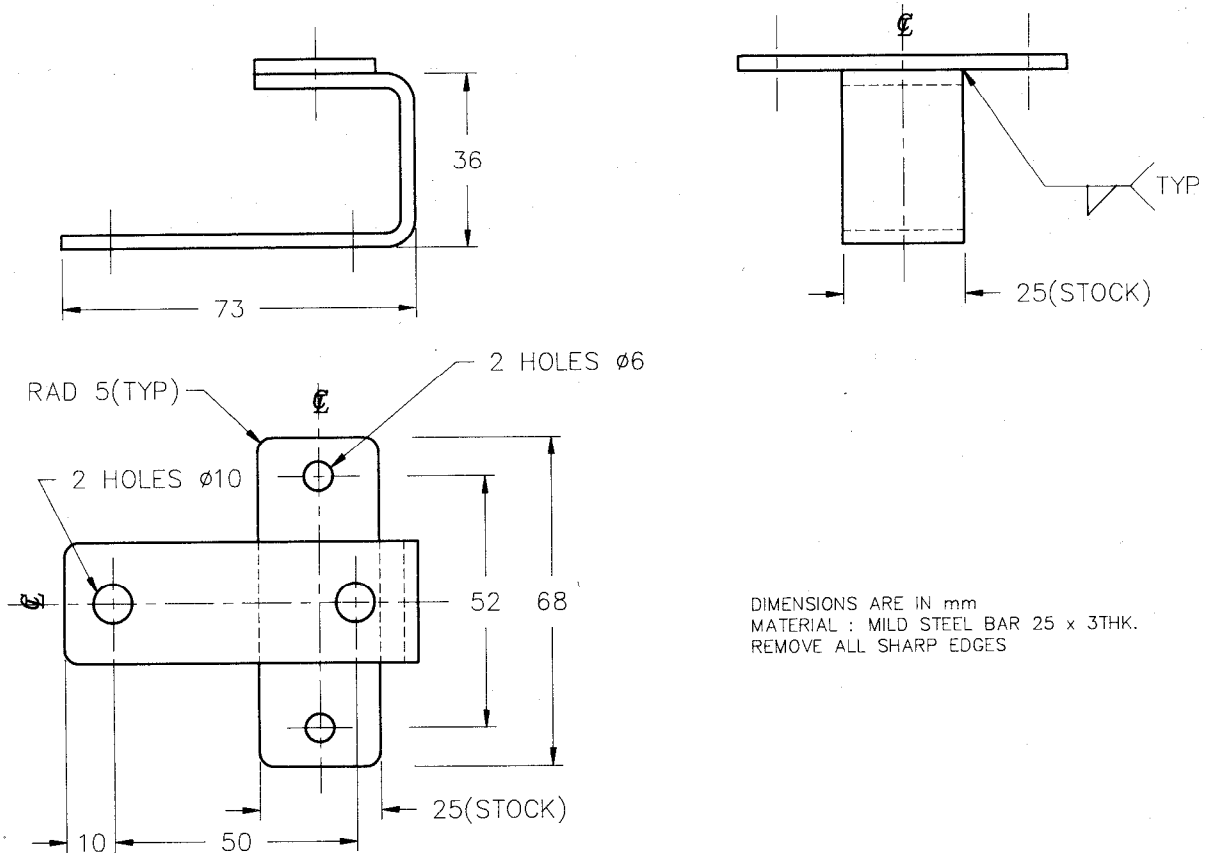

FIG 3 - AUSTSTEYR RIFLE CLIP RETAINING BRACKET
(UNIMOG ALL TYPES)

11. Screw together the AUSTSTEYR butt box to the existing butt box bracket using the screws retained in paragraph 9, and using the three rear mounting holes in the butt box.

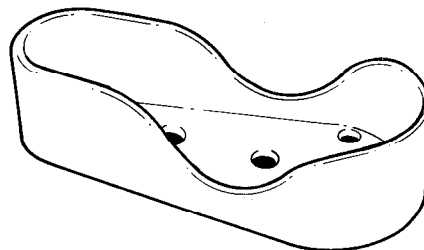

FIG 4 - BUTT BOX

UNCONTROLLED WHEN PRINTED

12. Secure the AUSTSTEYR rifle clip to the new retaining bracket by using the machine screws and washers Items 2 and 3, Table 2.
13. Position the new retaining bracket so that the top edge of the barrel clip is 570mm from the front edge of the butt box and the centre line of the bracket corresponds with the centre of the bolt holes in the existing cabin brackets.
14. Using the existing cabin brackets as a guide, mark and drill the new retaining bracket with a 10mm drill.
15. Bolt the retaining bracket to the existing cabin brackets using the nuts and bolts retained in paragraph 8. Ensure a 3mm clearance exists between the gas plug of the AUSTSTEYR rifle and the plastic rifle clip as shown in Fig 5.

Note:

1. Due to some inconsistency in the manufacturing tolerances of the brackets within the vehicles, individual fitting of the retaining bracket may have to be carried out to achieve the desired clearances.

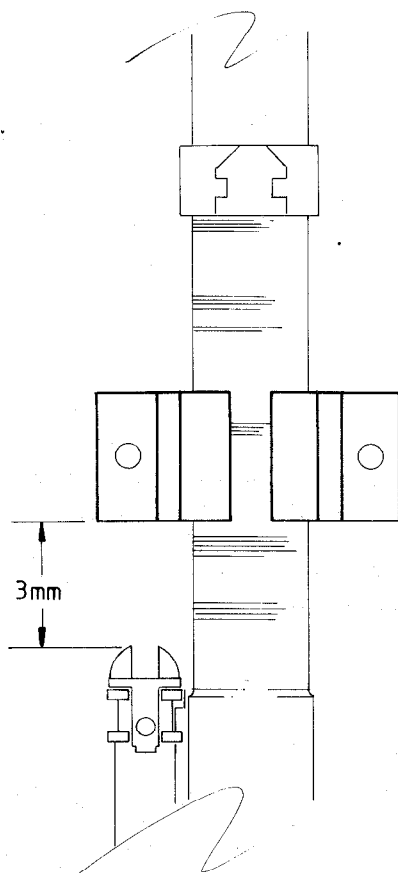

FIG 5 - GAS PLUG CLEARANCE

Modification Record Plate

16. On completion of the modification deface the numeral 29 from the modification record plate situated on the right hand side of the driver's seat base. (Vehicles modified in production are to have the modification plate defaced by the relevant Supply Battalion prior to issue).

E N D