

TRUCK, AIR DEFENCE, LAND ROVER 6 X 6, FFR, W/WINCH, FIRE UNIT VEHICLE (FUV)

TECHNICAL DESCRIPTION

This instruction is authorised for use by command of the Chief of Army. It provides direction, mandatory controls and procedures for the operation, maintenance and support of equipment. Personnel are to carry out any action required by this instruction in accordance with EMEI General A 001.

INTRODUCTION

1. This EMEI contains the technical description of the Truck, Air Defence, Land Rover 6 x 6, FFR, W/Winch, Fire Unit Vehicle (FUV) shown in Figure 1. All relevant weights, dimensions and performance figures are detailed in the data summary EMEI Vehicle G 280. Except for the rear body assembly, the mechanical characteristics are the same as the Truck, Cargo, Light, Winch, MC2, therefore, for further information relating to the mechanical functions of this vehicle, refer to EMEI Vehicle G 202.

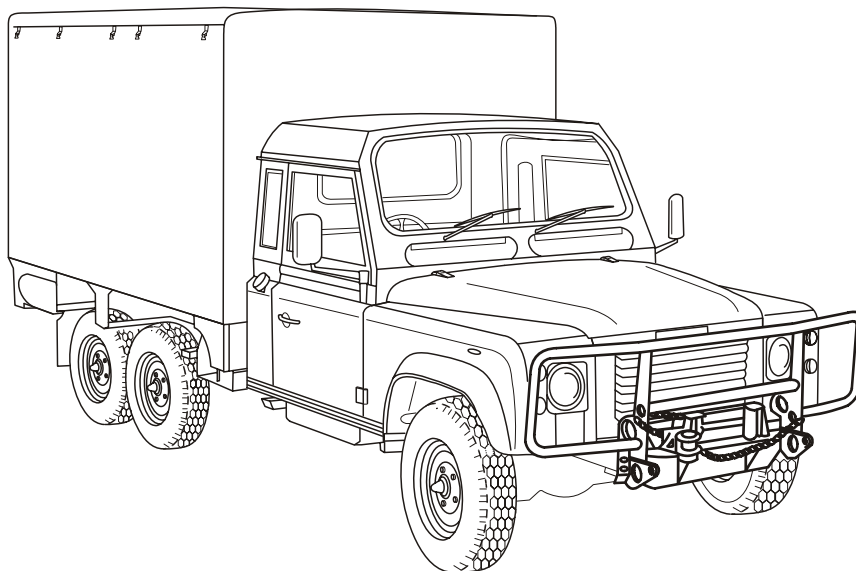

Figure 1 Truck, Air Defence, Land Rover 6 x 6, FFR, W/Winch, Fire Unit Vehicle (FUV)

GENERAL INFORMATION

Cargo Area Lighting

2. Lighting is provided in the cargo area by nine white and nine blue LED lights (Figure 2). Lights are mounted in brackets attached to the interior roof assembly. Each bracket houses one white and one blue LED light fitting. A three-position switch, fitted on the side of the BORG/COND stowage module, enables either white or blue LED lights to be selected for loading/unloading operations during normal conditions. An additional crash action override switch is mounted on the headboard above the missile stowage on the passenger's side. This switch allows for the three blue LED lights on the passenger's side to be switched on during either blackout or reduced lighting conditions. These three light units are sited above the Missile Module, Stand Stowage and Sight Stowage.

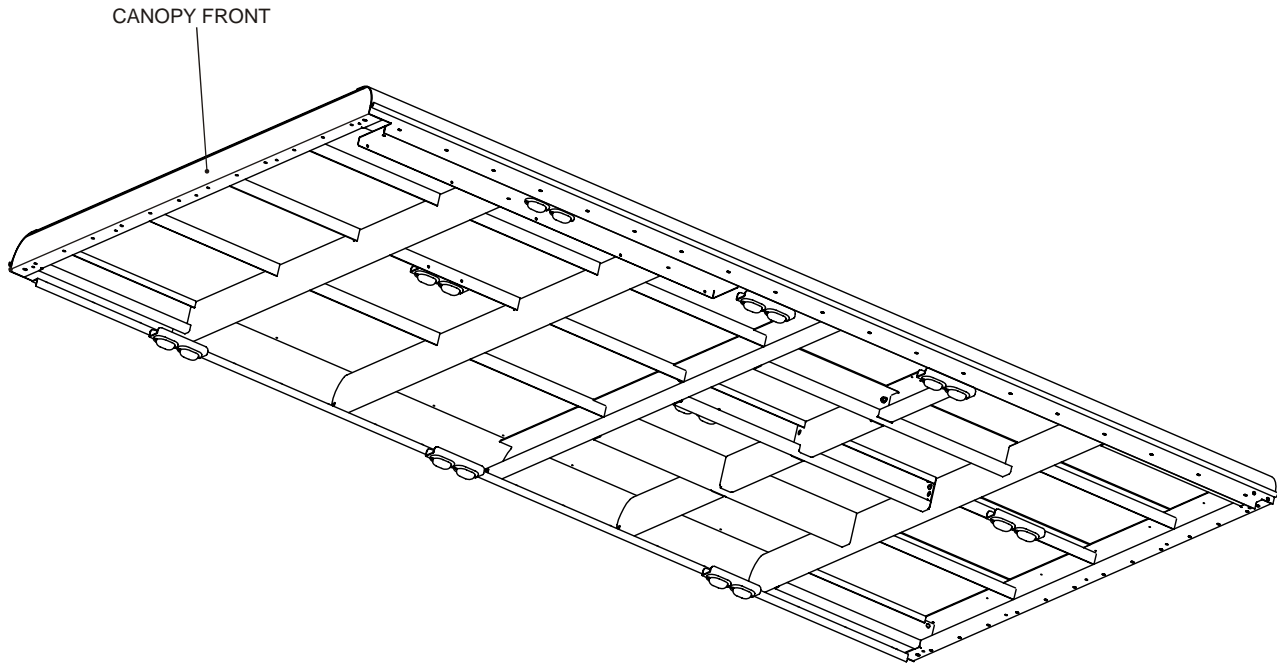

Figure 2 Cargo Area Lighting Layout

Rear Body

3. The vehicle's rear body utilizes a modified cargo tray (Figure 3) with stowages divided into four areas: missiles module, passenger's side module, driver's side module and under tray module. A solid roof covers the complete cargo area and is fitted with soft sides.
4. The missile module is configured to carry up to eight missiles in two compartments of four, accessed from each side of the vehicle. Mounted above the missile module is a general stowage area (Figure 4).
5. The rear passenger side module is located behind the missile stowage module on the left hand side of the vehicle. This module contains stowage for the operational stand, operational sight and Clip-on Night Sight (BORC/COND). It also has small compartments for stowage of miscellaneous items.
6. The rear driver's side module is located behind the missile stowage module on the right hand side of the vehicle. This module contains stowage for a Wagtail Combat Net Radio (CNR) communications backpack, TACCS Clark Mast accessory boxes, Interrogator Friend or Foe (IFF), and water jerricans. It also has small compartments for stowage of miscellaneous items.
7. The under tray stowage module is located at the rear and underneath the vehicle. The tray provides stowage for camouflage net poles, Clark Masts and Omni Directional Antennas. It is mounted on rollers and can be pulled out halfway for ease of access. The spring loaded shot bolt and anti-luce fittings provide the locking mechanism. A two fold flap fitted at the rear of the tray provides a safety guard for the tray for personnel closing the tray and can be utilised as an administration table.

UNCONTROLLED IF PRINTED

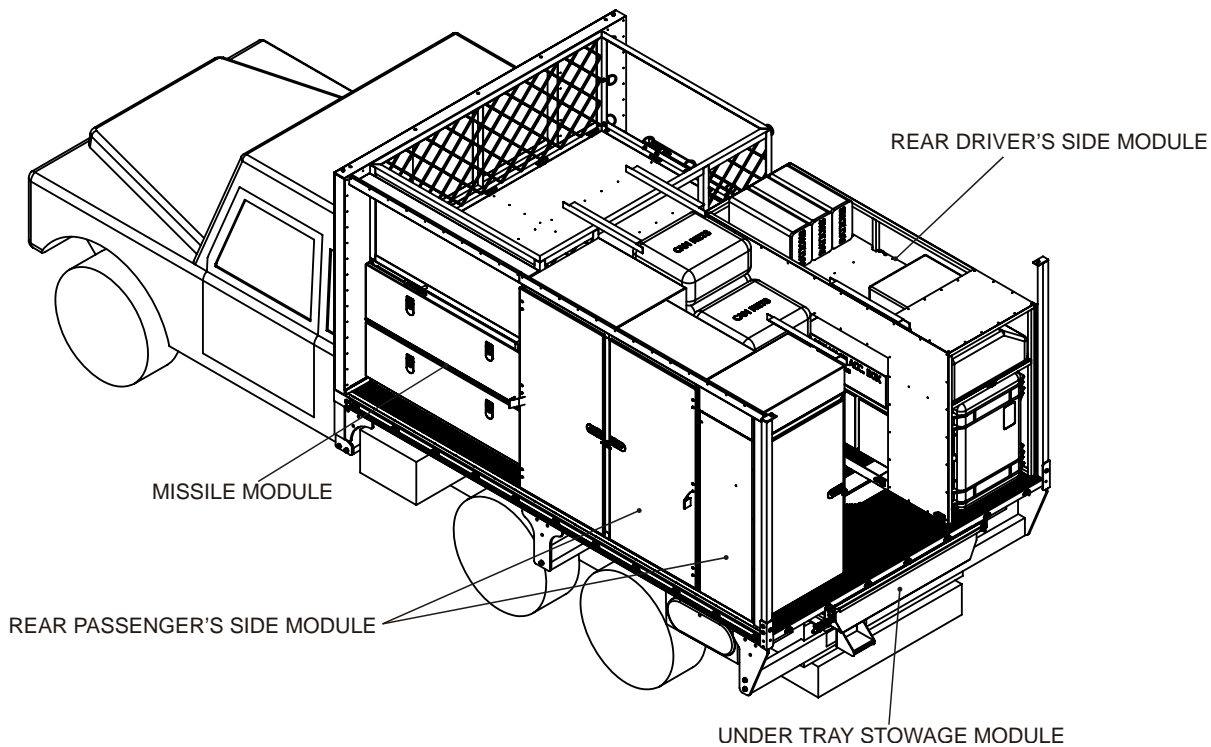

Figure 3 Rear Body (without canopy)

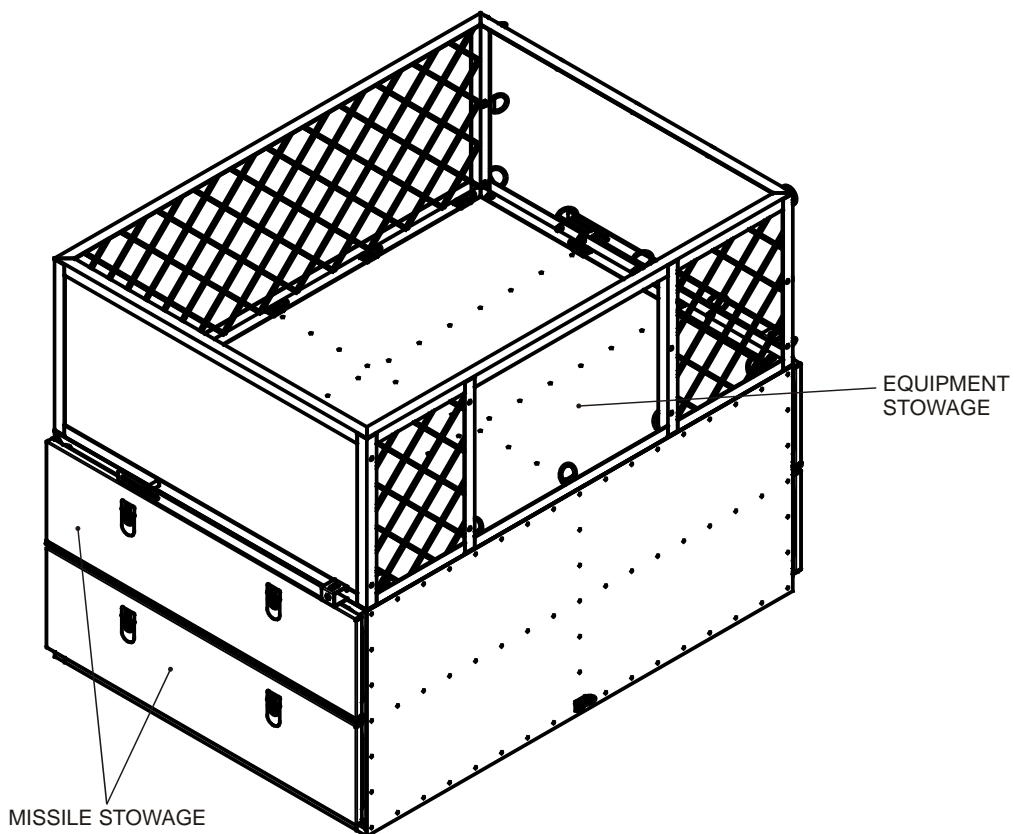

Figure 4 RBS 70 Missile Module and Equipment Stowage

UNCONTROLLED IF PRINTED

DETAILED DESCRIPTION

Rear Body

8. The rear body comprises: a cargo tray, a headboard, canopy and modules for the Fire Unit Vehicle comprising that part of the RBS 70 missile system.

Cargo Tray

9. The frame of the cargo tray (Figure 5) is constructed of aluminium (6063 series) components and consists of: two side coamings, end coamings and flooring. The side and end coamings are secured with angle brackets to form a rectangular shape. The flooring is mounted within the frame. Two rails, under the flooring, provide the support for the under tray stowage module.

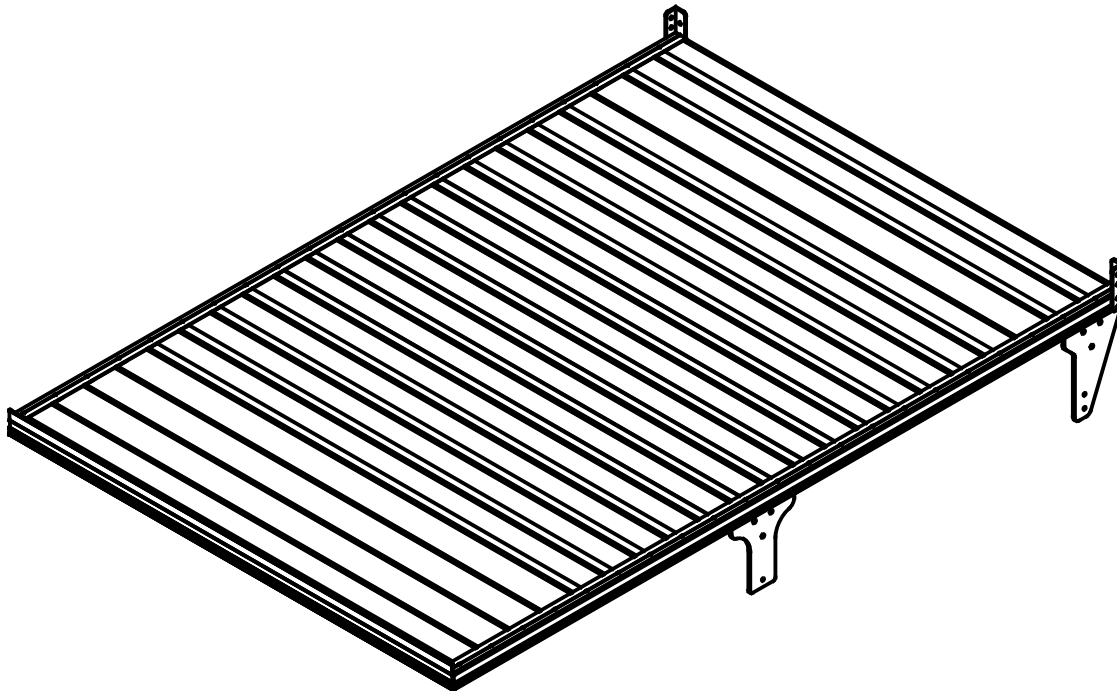

Figure 5 Common Cargo Tray

Canopy Assembly

10. The canopy assembly comprises of a roof assembly and two roof supports (Figure 6). The front of the canopy assembly is supported by the headboard assembly and the rear of the canopy is supported by the two supports. The roof assembly comprises of a series of support beams welded to form the roof shape and covered by three roof plates. Four tie down points allow for equipment to be secured on the top of the canopy. Three roll down barracuda panels are attached to the canopy for weather protection. Securing clips allow these panels to be either be rolled up to the top of the canopy or be rolled up and positioned on the top of the canopy.

UNCONTROLLED IF PRINTED

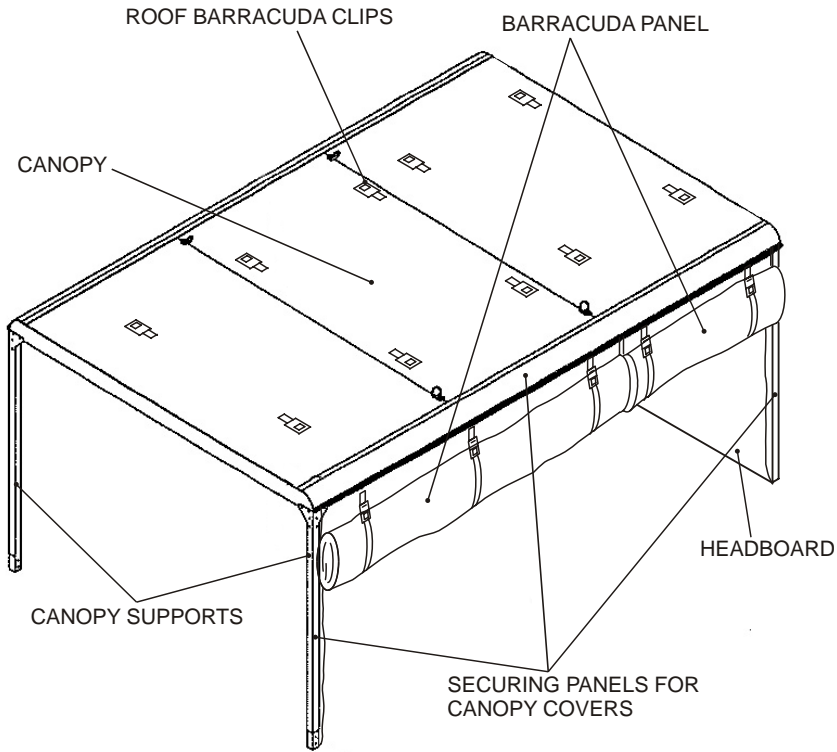

Figure 6 Canopy Assembly

RBS 70 Missile Stowage

11. The missile storage module (Figure 7) holds up to eight RBS 70 missiles in their storage containers in two racks containing four missiles each. The module is located immediately behind the vehicle cabin. The missiles can be accessed from either side of the vehicle.

12. The missile storage containers are secured in place with elasticised straps connected between the two footman's loops, one located on the upper inside surface of the missile storage module and the other located at the end of the missile storage rack guide rail. A swing bar fitted on each side of the stowage can be positioned to lock the missile storage doors.

13. A general purpose stowage area on top of the missile storage module is accessed via removable webbing from the centre aisle of the vehicle or from the right hand side of the vehicle.

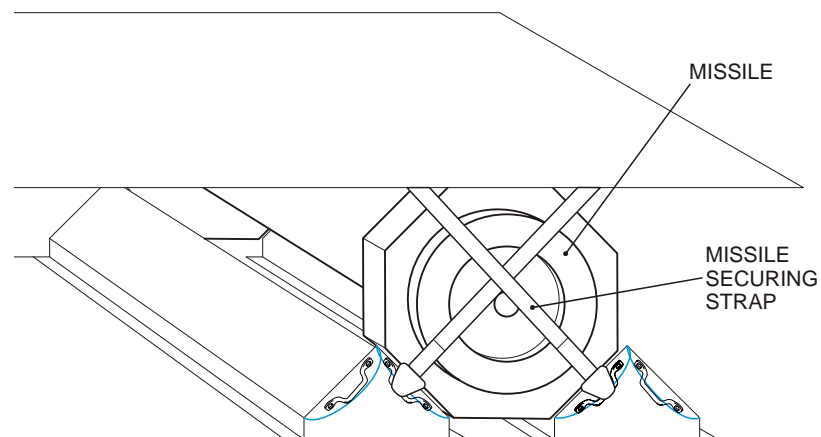

Figure 7 RBS 70 Missile Stowage (inside)

UNCONTROLLED IF PRINTED

Drivers Side Stowage

14. The rear driver's side module (Figure 8) is located behind the missile stowage module on the right hand side of the vehicle. This module contains stowage for a Wagtail Combat Net Radio (CNR) communications backpack, TACCS, IFF, ACC Box, TAC Box, Clark Mast Accessory Box and water jerrycans.

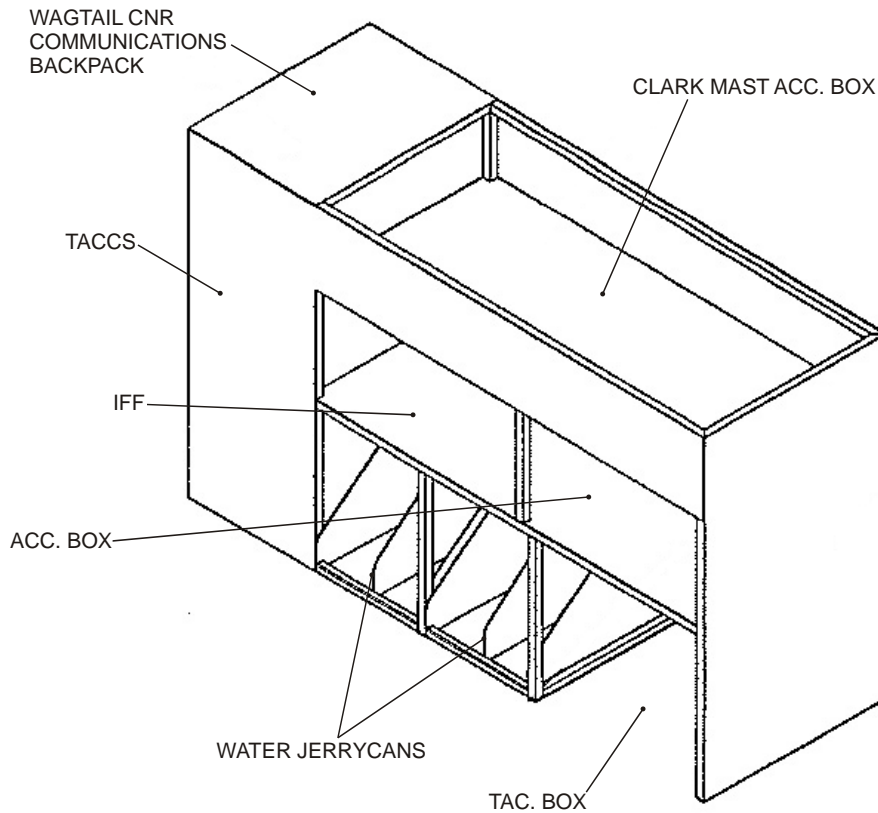

Figure 8 Drivers Side Stowage

Passengers Side Stowage

15. The rear passenger side module (Figure 9) is located behind the missile stowage module on the left-hand side of the vehicle. This module contains stowage for the operational stand, operational sight and clip-on night sight (BORC/COND) night sights.

UNCONTROLLED IF PRINTED

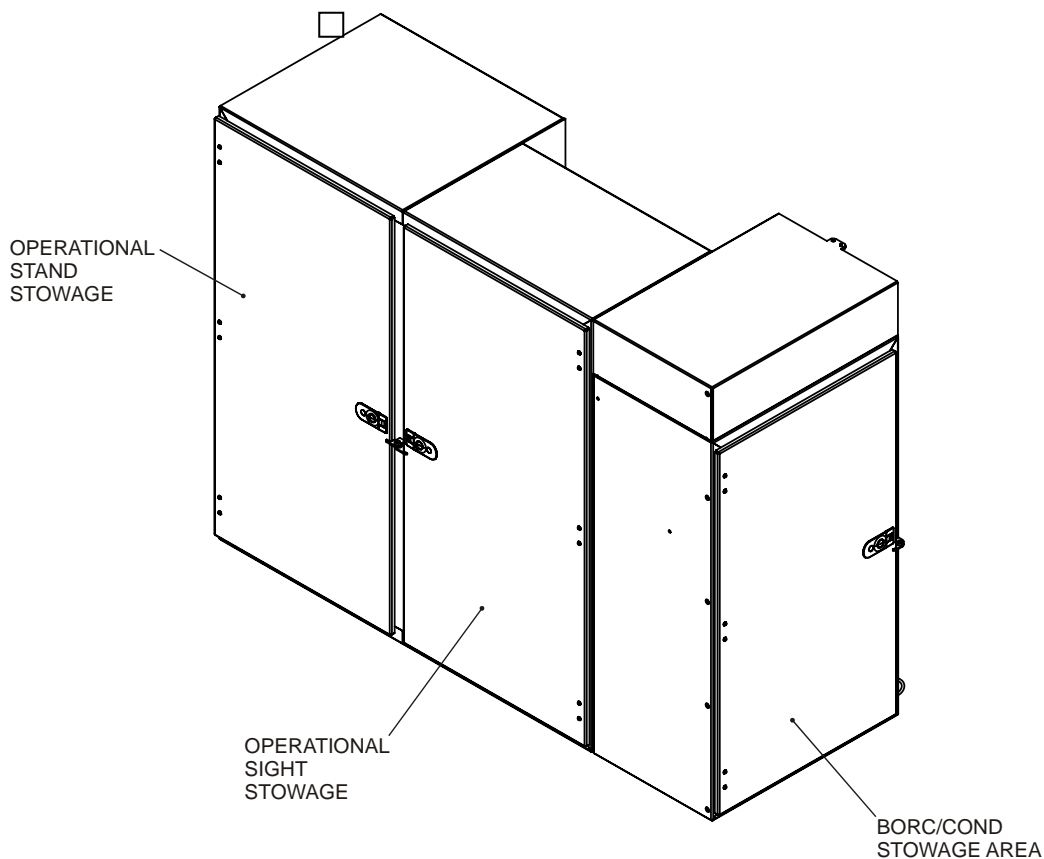

Figure 9 Passengers Side Stowage

Under Tray Stowage

16. The under tray stowage module is located at the rear and underneath the vehicle (Figure 10). The tray provides stowage for camouflage net poles, Clark Masts and Omni Directional Antennas. It is mounted on rollers and can be pulled out halfway for ease of access. The spring loaded shot bolt and anti-luce fittings provide the locking mechanism. A two fold flap fitted at the rear of the tray provides a safety guard for the tray for personnel closing the tray and can be utilised as an administration table.

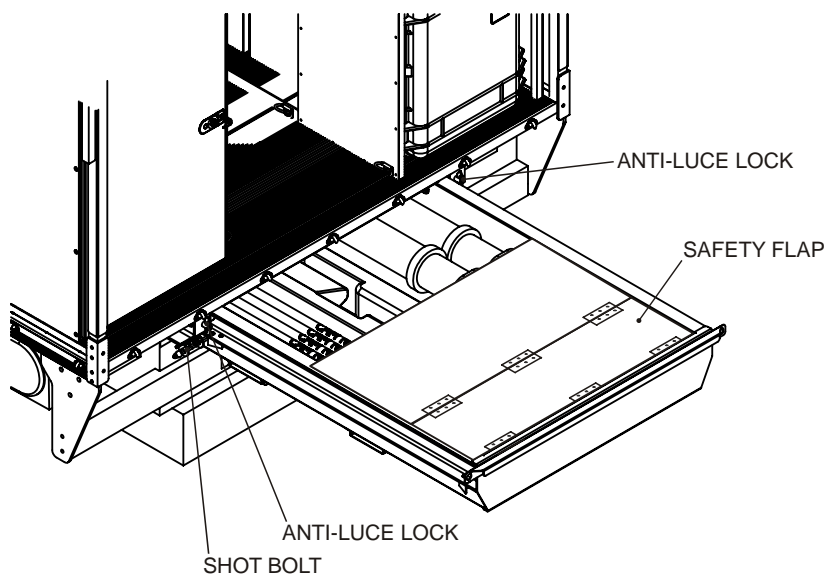

Figure 10 Under Tray Stowage

END

Distribution List: **VEH G 21.2 – Code 2** (Maint Level)
(Sponsor: LV SPO, Lt B Veh Section)
(DMO Job No AMP063.69)

UNCONTROLLED IF PRINTED