

**TRUCK, CARGO, WITH CRANE, HEAVY, MC3 (MACK)  
TECHNICAL DESCRIPTION**

This instruction is authorised for use by command of the Chief of Army. It provides direction, mandatory controls and procedures for the operation, maintenance and support of equipment. Personnel are to carry out any action required by this instruction in accordance with EMEI General A 001.

**TABLE OF CONTENTS**

	<b>Page No</b>		<b>Page No</b>
Introduction .....	3	Power Supply Box (PSBI) .....	14
Associated Publications .....	3	Main Power Connection Box (MPCB).....	16
Principles of Operation .....	3	Column Box .....	16
Control Systems.....	3	Sensors and Indicators .....	16
Arrangement of the Equipment.....	4	Dump Valve .....	17
Detailed Technical Description .....	5	Diagnostic Terminal .....	17
Crane Base .....	5	Bar Codes.....	17
Slew Cylinder Hydraulic Circuit .....	5	Wiring Connections.....	17
Crane Body .....	5	Hydraulic System .....	17
Inner Boom Cylinder .....	6	Power Take Off (PTO) .....	18
Inner Boom.....	7	Hydraulic Pump .....	18
Outer Boom Cylinder.....	7	Main Control Valve .....	18
Outer Boom and Boom Extensions.....	7	Outrigger Control Valve .....	18
Boom Extension Cylinder.....	8	Load Holding Valves.....	18
Outriggers .....	9	Sequencing Valve.....	18
Remote Control System.....	9	Outrigger Leg Check Valve.....	19
General .....	9	Inline Restrictor Valve.....	19
Power Box (PSBI) .....	10	Hose Rupture Valve.....	19
Combidrive Controller .....	10	Oil Tank and Return Filter.....	20
DA Modules.....	11	Oil Cooler.....	20
Positioners .....	11	Hydraulic Circuits .....	20
Pressure Reduction Filter.....	12	Inner and Outer Boom .....	20
Remote Control Hydraulic System.....	12	Boom Extensions.....	23
Safety Protection and Control Equipment.....	13	Slew .....	23
Overload Protection .....	13	Tilt .....	24
Automatic Dumping Function (ADO).....	13	Outrigger Extensions .....	24
Height Warning – Inner Boom.....	14	Outrigger Leg.....	24
System Components.....	14	Wiring Harness.....	25
Microprocessor Box (SPACE Box).....	14		

**LIST OF FIGURES**

	<b>Page No</b>		<b>Page No</b>
Figure 1 Crane Major Components.....	4	Figure 12 PSBI Box .....	16
Figure 2 Crane Base.....	5	Figure 13 Sequencing Valve.....	18
Figure 3 Crane Body and Inner Boom .....	6	Figure 14 Outrigger Leg Check Valve .....	19
Figure 4 Inner Boom and Outer Boom Cylinder.....	6	Figure 15 Inline Restrictor Valve.....	19
Figure 5 Outer Boom, Boom Extensions and Extension Cylinder .....	8	Figure 16 Hose Rupture Valve .....	20
Figure 6 Boom Extension Cylinder.....	8	Figure 17 Hydraulic Circuit Diagram.....	21
Figure 7 Remote Control System.....	10	Figure 18 Boom Extension Cylinder Operation .....	23
Figure 8 Combidrive Controller .....	11	Figure 19 Slew Cylinder Operation.....	24
Figure 9 Positioner .....	12	Figure 20 Front Wiring Harness.....	25
Figure 10 Remote Control Hydraulic Circuit.....	13	Figure 21 Cab Wiring Harness .....	26
Figure 11 SPACE Components .....	15	Figure 22 Rear Wiring Harness .....	27

UNCONTROLLED IF PRINTED

**LIST OF TABLES**

	<b>Page No</b>	<b>Page No</b>
Table 1 Location of Identification Numbers.....	28	

UNCONTROLLED IF PRINTED

## INTRODUCTION

1. This EMEI supplement describes the technical system and details of the crane fitted to the Truck, Cargo, With Crane, Heavy, MC3 (Mack). All relevant weights, dimensions and performance figures are detailed in the Data Summary, EMEI Vehicle G 710. For further information on the basic truck, refer to EMEI Vehicle G 702.

### Associated Publications

2. Reference may be necessary to the latest version of the following documents:
- [EMEI Vehicle G 702](#) – Truck, Cargo, Heavy, MC3 – Mack – Technical Description;
  - [EMEI Vehicle G 709](#) – Truck, Cargo, Heavy, MC3, Mack – Servicing Instruction;
  - [EMEI Vehicle G 710](#) – Truck, Cargo, With Crane, Heavy, MC3, Mack – Data Summary;
  - [EMEI Vehicle G 713](#) – Truck, Cargo, With Crane, Heavy, MC3, Mack – Light Grade Repair;
  - [EMEI Vehicle G 714](#) – Truck, Cargo, With Crane, Heavy, MC3, Mack – Medium and Heavy Grade Repair;
  - Repair Parts Scale 02162; and
  - Technical Regulation of Army Materiel Manual (TRAMM) (available from DTR-A website <http://intranet.defence.gov.au/armyweb/Sites/DTRA>).

## PRINCIPLES OF OPERATION

3. The Truck, Cargo, With Crane, Heavy, MC3 (Mack), is a 6 x 6 vehicle designed to negotiate any terrain or gradient that will allow wheel traction. The vehicle incorporates a hydraulic crane to facilitate self loading/unloading and the transfer of loads between vehicles. The vehicle has the capacity to carry an eight tonne load cross-country and ten tonnes on the highway.
4. The crane has a lifting capacity of 1 170 kg at 7.0 metres. A label is fixed to the crane at each operator station adjacent to the controls detailing the maximum safe working load/radius for the crane.
5. A work lamp is fitted on the underside of the outer boom to allow illumination during night operations. A toggle switch for the lamp is located at each operator station on either side of the vehicle.

### NOTE

The work lamp is wired into the park light circuit so that it is controlled under blackout conditions.

### Control Systems

6. The crane is fitted with Manual, Remote and Electronic Safety Control Systems.
7. **Manual Control System.** The Manual Control System includes crane and outrigger controls. The main crane control valve and its control levers are mounted on the left-hand side of the vehicle and are connected by transverse rods to a set of 'same sequence' cross controls on the right-hand side of the vehicle for convenience. These levers control the slew, inner boom, outer boom, boom extension and tilt functions of the crane. The function of each of the control levers is indicated by means of a symbol located adjacent to the lever.

### WARNING

**All of these functions can be controlled from either side of the vehicle. However, when folding and unfolding the crane, always operate from the left-hand side of the vehicle.**

8. A set of outrigger controls is mounted on either side of the vehicle. These levers are used to control the outrigger extension cylinders and the leg cylinders on each side of the vehicle. The function of each of the control levers is indicated by means of a symbol located adjacent to the lever.
9. **Remote Control System.** The Combidrive Remote Control System is an electronic-hydraulic system for remote control of the main control valve in the crane. Its digital electronic system contains a number of

microprocessors that receive signals from the remote controller and convert them to commands for the operating hydraulic system that governs the crane valve spools.

**10. Electronic Safety Control System.** Speed, Payload, Accessories, Certificate and Electronics (SPACE) is a microprocessor based electronic safety system fitted to control safety functions during operation of the crane. These safety functions include:

- a. overload protection;
- b. automatic dumping function; and
- c. height warning – inner boom.

**ARRANGEMENT OF THE EQUIPMENT**

**11.** The crane comprises the following sub-assemblies (Figure 1):

- a. the crane body;
- b. the inner boom (and cylinder);
- c. the outer boom (and cylinder);
- d. the boom extensions (and cylinder);
- e. the outriggers;
- f. the manual control mechanisms; and
- g. the remote control system.

UNCONTROLLED IF PRINTED

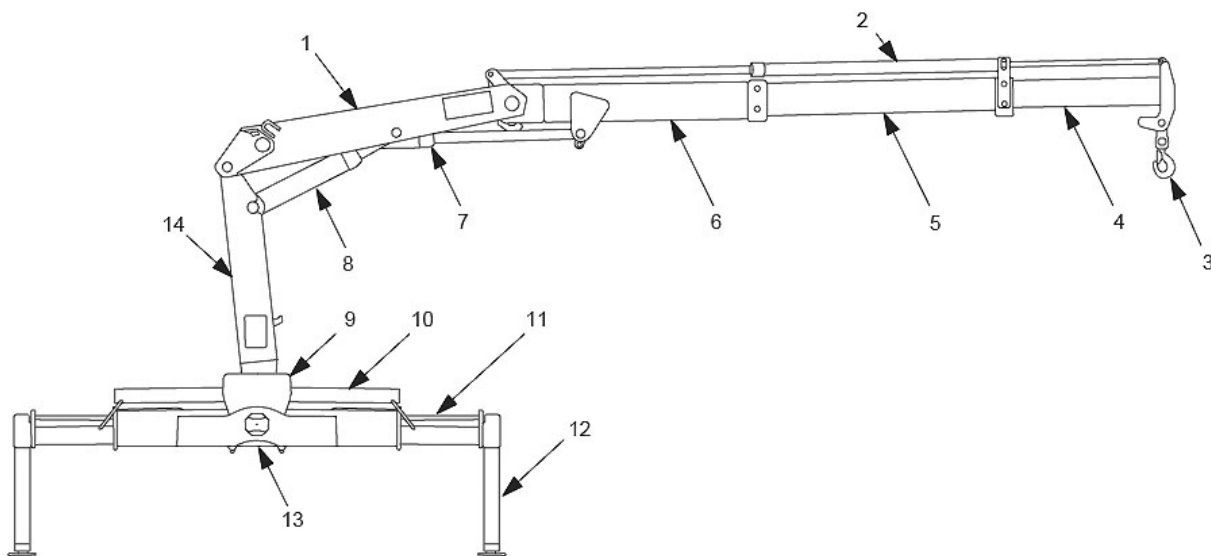

- |   |                         |    |                                 |
|---|-------------------------|----|---------------------------------|
| 1 | Inner boom              | 8  | Inner boom cylinder             |
| 2 | Boom extension cylinder | 9  | Slewing housing                 |
| 3 | Load hook               | 10 | Slewing cylinder                |
| 4 | Second boom extension   | 11 | Outrigger extension cylinder    |
| 5 | First boom extension    | 12 | Outrigger leg                   |
| 6 | Outer boom              | 13 | Tilt cylinder (not illustrated) |
| 7 | Outer boom cylinder     | 14 | Crane body                      |

**Figure 1 Crane Major Components**

**DETAILED TECHNICAL DESCRIPTION**

**Crane Base**

12. The crane base, which is bolted to the transverse mounted outrigger beam, consists of a slewing gearbox and its operating cylinder. The outrigger beam is attached to a tilt rocker shaft. This shaft is rotated by the tilt cylinder to lower the crane to the rear tray thus reducing the crane height for air transportability (Figure 2).

**Slew Cylinder Hydraulic Circuit**

13. The slewing system of the crane is a rack and pinion type, i.e. two opposing single-acting cylinders with a common piston rod (Figure 2, Item 4) which act on a cog wheel fixed to the lower part of the crane body. When oil is pumped into one of the cylinders the rack will rotate the cog wheel which moves the loader body. The slewing gearbox enables the crane to operate through an arc of approximately 400°.

14. The rear of the slewing housing is secured to a three-point bridge using a fixing yolk. The function of the three-point bridge is to absorb the twisting movements of the flexible truck chassis when the truck is running over uneven ground. Consequently, the crane base can be of a stiff and rigid design that can be fastened to the crane body. The slewing housing is rigidly mounted to the transverse outrigger beam by six bolts. The tilt rocker shaft is fixed to the outrigger beam by means of welded gussets. The shaft is mounted at either end to 'I' beams, using pillow block bearings. The 'I' beams are fixed to angle brackets and bolted to the vehicle chassis. When the rocker shaft is rotated by the tilt cylinder, the crane is lowered to (or raised from) the rear tray of the vehicle. Paragraphs 101 to 105 detail the complete operation of the slew and tilt cylinder hydraulic circuit.

UNCONTROLLED IF PRINTED

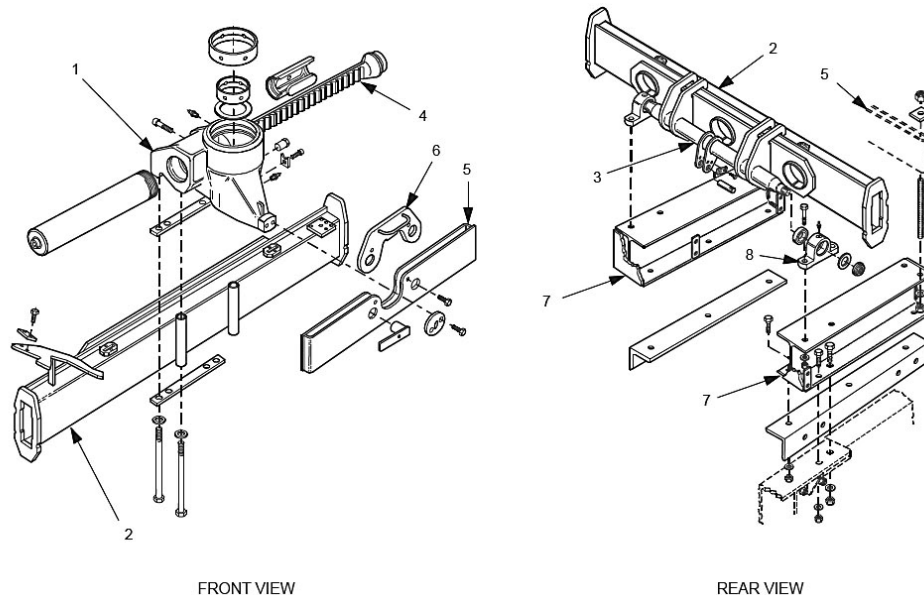

- |   |                   |   |                      |
|---|-------------------|---|----------------------|
| 1 | Crane base        | 5 | Three point bridge   |
| 2 | Outrigger beam    | 6 | Fixing yoke          |
| 3 | Tilt Rocker shaft | 7 | I-beam               |
| 4 | Gear rack         | 8 | Pillow block bearing |

**Figure 2 Crane Base**

**Crane Body**

15. The crane body assembly consists of a body post with an integrally mounted pinion gear that is supported in column bushings fitted to the slewing housing. The pinion gear indexes with the rack piston of the slewing cylinder. When the cylinder is operated, the movement of the rack imparts a turning motion on the post, enabling the crane to operate through an arc of approximately 400° (Figure 3).

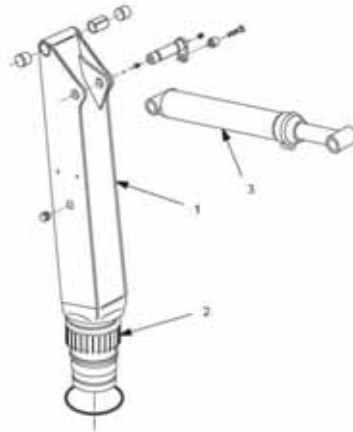

- 1 Body post
- 2 Pinion gear
- 3 Inner boom cylinder

**Figure 3 Crane Body and Inner Boom**

**16.** The body post is sealed into the slewing housing by means of an O ring at the top and a seal at the bottom. It is fitted with bushed mounting points for the inner boom and gussets for the fixed end of the inner boom cylinder. A parking support is welded to the body to accommodate the outer boom when it is at rest in the stowed position.

#### Inner Boom Cylinder

**17.** The function of the inner boom cylinder is to raise and lower the inner boom during crane operations. It is mounted on the upper section of the crane body and its piston rod end is mounted to the underside of the inner boom (Figures 3 and 4). A load holding valve is mounted on the underside of the cylinder to protect the load from lowering when the hydraulic system is inactive.

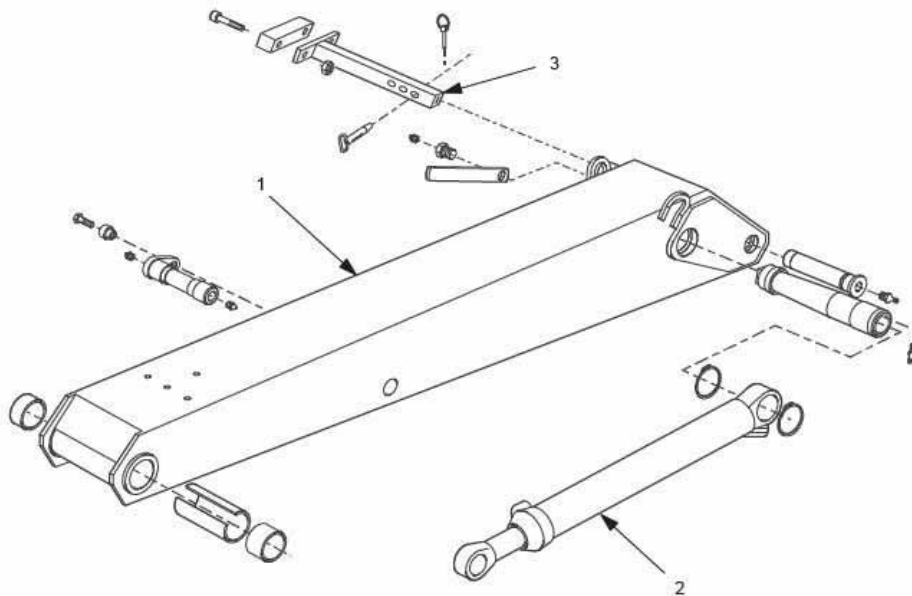

- 1 Inner boom
- 2 Outer boom cylinder
- 3 Resting post

**Figure 4 Inner Boom and Outer Boom Cylinder**

**18.** The cylinder is controlled by a spring-loaded, self-centring control lever mounted at the main control valve or the alternate control on the opposite side of the vehicle. The cylinder can also be controlled by the Combidrive remote controller.

UNCONTROLLED IF PRINTED

### **Inner Boom**

- 19.** The inner boom assembly has provision for four main attachments as follows (Figure 4):
- a.** a mounting point for fixture to the crane body – a pivot pin and bushes are used to mount the inner boom to the crane body;
  - b.** an external mounting point for the fixed end of the outer boom cylinder – a pivot pin is used to mount the cylinder;
  - c.** an internal mounting point for the piston rod end of the inner boom cylinder towards the leading end of the boom – a pivot pin is used to mount the cylinder; and
  - d.** a mounting point for the outer boom at the leading end of the boom – the outer boom has an integral offset mounting point which pivots in bushes in the inner boom.
- 20.** In each case, either lock plates or circlips are used to secure the pivots. All pivots are fitted with grease nipples for lubrication of the joints. Suitable hose restraints are employed to prevent fouling of the hoses during crane operations.
- 21.** A rubber cushioned resting post is fitted to the inner boom, opposite the outer boom cylinder's fixed end mounting point. This post rests on the rear tray when the crane is tilted to the reduced height position. Paras 93 to 96 detail the complete operation of the inner boom cylinder hydraulic circuit.

### **Outer Boom Cylinder**

- 22.** The function of the outer boom cylinder is to raise and lower the outer boom during crane operations. It is mounted on the outside of the upper section of the inner boom and its piston rod end is mounted to the underside of the outer boom (Figures 4 and 5). A load holding valve is mounted on the top of the cylinder to protect the load from lowering when the hydraulic system is inactive.
- 23.** The outer boom cylinder is controlled by a spring-loaded, self-centring control lever mounted at the main control valve or the alternate control on the opposite side of the vehicle. It can also be controlled by the Combidrive remote controller. Paras 93 to 96 detail the complete operation of the outer boom cylinder's hydraulic circuit.

### **Outer Boom and Boom Extensions**

- 24.** The outer boom is constructed of hollow cross-section steel. It attaches to the inner boom by means of an offset pivot pin. The offset alignment allows for compact folding of the booms when stowing the crane. The outer boom is raised and lowered by the action of the outer boom cylinder (Figures 4 and 5).
- 25.** The hollow construction of the outer boom allows for the internal retraction of the two boom extensions. The boom extensions are extended and retracted by a duplex cylinder mounted above the outer boom.
- 26.** The formation of the outer boom and the extensions are of a hexagonal shape, which gives a lightweight profile with good lateral guidance. Slide pads are fitted between the extension profiles to centralise the booms and to reduce the friction effect when operating the extension function. These slide pads are manufactured of a self-lubricating material. They are adjustable and can easily be replaced when they are worn out.
- 27.** The leading end of the second boom extension incorporates a load hook and a mounting point for the boom extension cylinder (the smaller piston rod end).
- 28.** As illustrated in Figures 1 and 5, the outer boom assembly has two hydraulic cylinder mounting points; one on the underside of the trailing end of the boom for the outer boom cylinder and one on the top of the trailing end of the boom for the boom extension cylinder (the larger piston rod end). These cylinders are secured using lock plates and circlips. The outer boom cylinder pivot is fitted with grease nipples for lubrication of the joint.
- 29.** Suitable hose restraints are employed on and around the outer boom to prevent fouling of the hoses during crane operations.
- 30.** A work lamp is fitted on the underside of the outer boom to allow illumination during night operations.
- 31.** A parking latch is fitted to the underside of the trailing end of the outer boom to act as a restraint for the boom extensions when the crane is at rest in the stowed position.

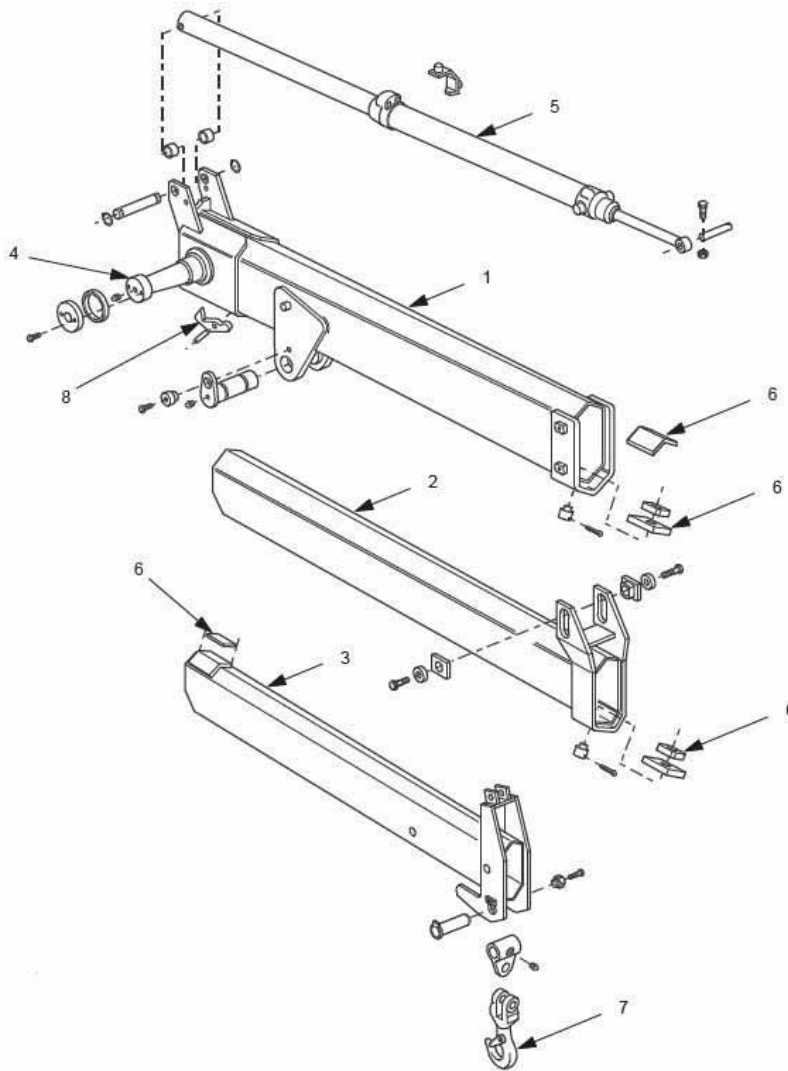

- |   |                       |   |                 |
|---|-----------------------|---|-----------------|
| 1 | Outer boom            | 5 | Duplex cylinder |
| 2 | First boom extension  | 6 | Slide pads      |
| 3 | Second boom extension | 7 | Load hook       |
| 4 | Offset pivot pin      | 8 | Parking latch   |

**Figure 5 Outer Boom, Boom Extensions and Extension Cylinder**

### Boom Extension Cylinder

**32.** The function of the boom extension cylinder is to extend and retract the outer boom extensions during crane operations. It is mounted on top of the outer boom with the larger piston rod fixed to the outer boom adjacent to the offset pivot pin and the smaller piston rod anchored to the leading end of the second extension. The cylinder tube is mounted to the leading end of the first extension (Figure 5). A cross-sectional view of the duplex cylinder is shown at Figure 6.

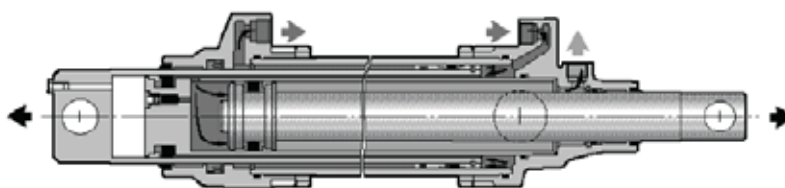

**Figure 6 Boom Extension Cylinder**

UNCONTROLLED IF PRINTED



**33.** The cylinder consists of an outer and an inner piston. The outer piston (larger piston rod) is intended to extend first and retract last.

**34.** The cylinder is controlled by a spring loaded, self-centring control lever mounted at the main control valve or the alternate control on the opposite side of the vehicle. It can also be controlled by the Combidrive remote controller. Paras 98 to 100 detail the complete operation of the boom extension cylinder's hydraulic circuit.

### **Outriggers**

**35.** The crane is equipped with hydraulically operated outriggers, mounted either side of the vehicle. For extra stability, each outrigger can be extended further outward using the hydraulic outrigger extension mechanism. Each leg is a hydraulic cylinder which is extended to touch the ground to create a stable platform for crane operations. Stability can be increased by the use of dunnage or other base plate material.

**36.** The hollow outrigger beam, which is part of the crane base, houses the extension beams to which the outrigger legs are attached. These extension beams are extended and retracted as required, using the accompanying hydraulic cylinders. The outrigger legs are stowed in the upside down position and are pivoted to the upright position by the movement of the leg's hydraulic piston acting against an external cam arrangement. The leg is fixed in either the up or down position by means of a spring-loaded lock pin and handle. The left-hand outrigger control levers are mounted at the outrigger spool valve and a set of cable controlled levers are located on the right-hand side of the crane. Paras 107 to 112 detail the complete operation of the outrigger leg cylinder and extension cylinder hydraulic circuits.

### **REMOTE CONTROL SYSTEM**

#### **General**

**37.** The remote control system is an electronic-hydraulic system for remote control of the main control valve in the crane. Signals received from the remote controller are passed to a number of microprocessors contained within the electronic system which interprets them as commands to operate the hydraulic system.

**38.** The microprocessor in the controller transmits a 'protocol' 45 times per second to the digital amplifiers (DA modules). The signals in the microprocessor in each DA module are converted into a proportional current and fed to the solenoids. The current to the solenoids causes a corresponding movement of the spool valve to operate the appropriate crane function. A special safety check is performed continuously during operation and each time the stop button on the controller is pulled.

**39.** The crane's remote control system consists of the following components (Figure 7):

- a.** a power box (PSBI);
- b.** a Combidrive controller;
- c.** the DA modules;
- d.** the positioners;
- e.** a pressure reduction filter; and
- f.** the hydraulic system.

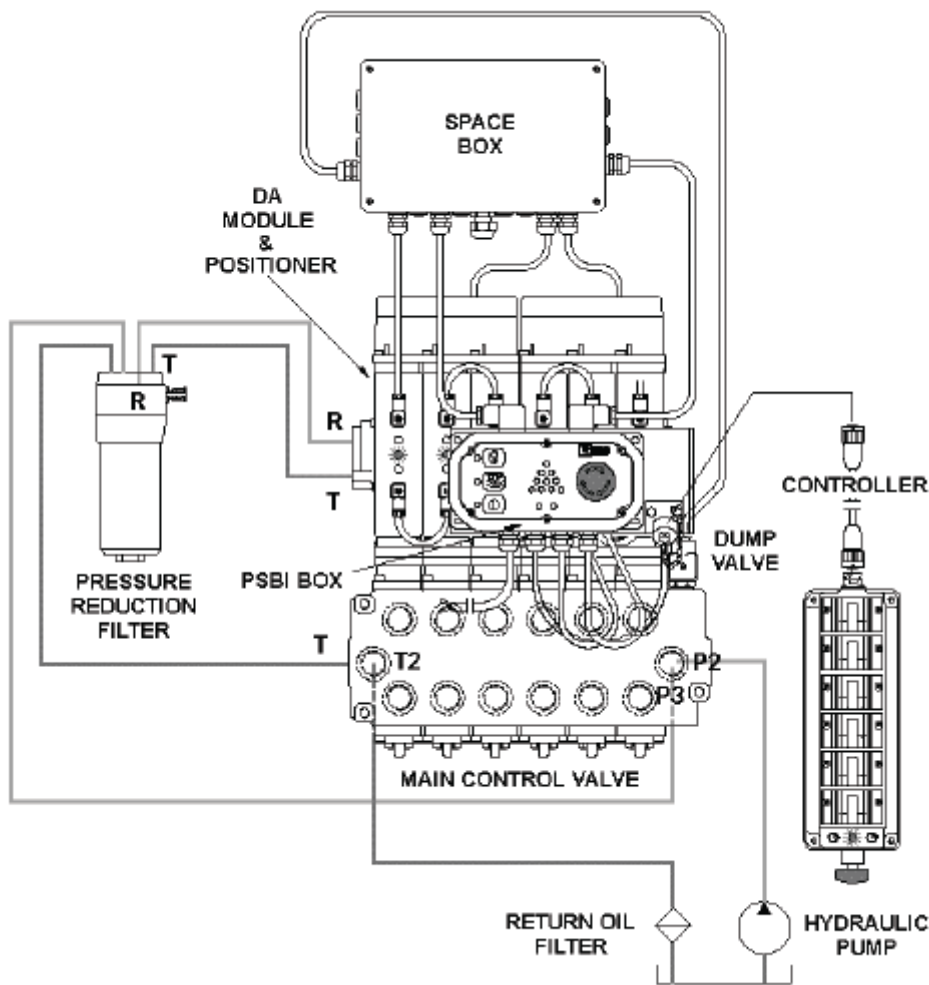

Figure 7 Remote Control System

UNCONTROLLED IF PRINTED

### Power Box (PSBI)

40. The PSBI is used to prepare the crane's control system for either manual or remote operation and to control various other functions of the crane. It contains an emergency stop button, an on/off button, a manual/remote selector button, an overload protection (OLP) release button, and a number of indicator lights. The PSBI is located at the operator's control station on the left-hand side of the vehicle.

41. The PSBI box is discussed in greater detail in Para 68 and 69.

### Combidrive Controller

42. The controller is used to allow remote control over the operations of the crane. A 15 metre cable is supplied to connect the controller to the crane control system. The connection is made on the left-hand side of the vehicle adjacent to the PSBI box. The controller is equipped with six proportional control operating levers to control the slewing, inner boom, outer boom and boom extension functions of the crane. Two of the levers are not used. When not in use, the controller is stowed in a pouch mounted on the back wall of the vehicle cab.

43. The controller is fitted with an emergency stop button, a three position crane speed toggle switch, an indicator light, a spring loaded toggle switch (not used) and two push buttons (horn button is not used) (Figure 8).

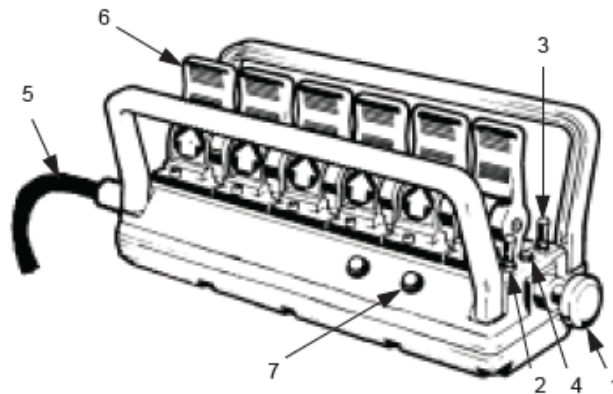

- |   |                          |   |                    |
|---|--------------------------|---|--------------------|
| 1 | Stop button              | 5 | Control cable      |
| 2 | Toggle switch (not used) | 6 | Control levers     |
| 3 | Speed control switch     | 7 | OLP release button |
| 4 | Indicator lamp           |   |                    |

**Figure 8 Combdrive Controller**

**44. Stop Button.** When the stop button (Figure 8, Item 1) is pushed in, oil is dumped and there is no current supplied to the DA modules, disabling the crane operation.

**45. Speed Control Switch.** If the speed control switch (Figure 8, Item 3) is placed in the centre position, maximum speed is maintained. When the switch is pushed away from the operator, 20% of the maximum speed is available. When the switch is pulled toward the operator, 50% of the maximum speed is available.

**46. Indicator Lamp.** In normal operation, the indicator lamp (Figure 8, Item 4) blinks continuously.

**47. Control Cable.** The control cable (Figure 8, Item 5) is a screened 2-core cable fitted with Cannon connectors.

**48. Control Levers.** Each control lever (Figure 8, Item 6) forms a module in the controller, and each module is connected to a circuit card in the base of the controller. One of the functions of this card is to identify each lever location (there are six locations). The control lever is mounted using double sealed ball bearings. An inductive sender that gives a voltage which is proportional to the lever deflection is provided. This voltage is then converted in the controller to a 'protocol' which is transmitted to the DA modules.

**49. Release Button.** This button (Figure 8, Item 7) is used to momentarily override the overload protection (OLP) function in certain overload situations.

#### DA Modules

**50.** DA modules receive signals from the Combdrive controller and relay them to the solenoids in the positioners.

**51.** DA modules contain microprocessors and amplifiers which control the positioner solenoids. The positioners are located directly above each valve unit where the DA modules are attached.

#### Positioners

**52.** Positioners are servo valves governing control valve functions, which in turn control crane functions (Figure 9).

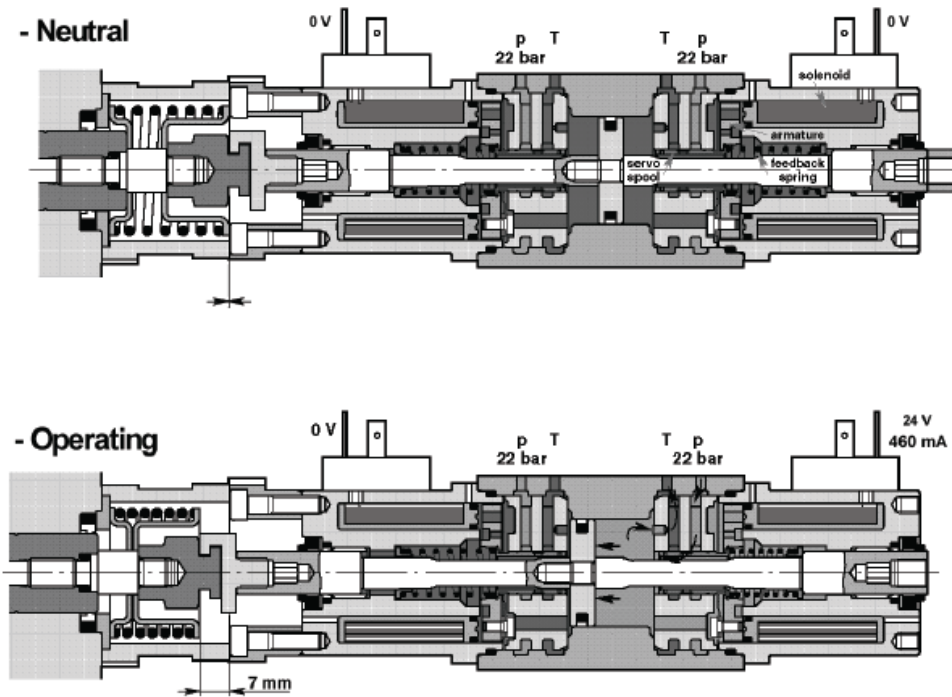

Figure 9 Positioner

53. Oil is supplied to the positioner from the pressure reduction filter. Supply pressure is 2.2 MPa. When no current is applied to the solenoid, the return spring forces the armature and servo spool rearward. The servo spool is in the closed position.
54. When a pulse width modulated current of between 0-500 mA is supplied to the solenoid, a magnetic force proportional to the current is generated which pulls the armature and servo spool toward the solenoid, allowing oil to flow into the positioner, influencing the piston and the main valve spool.
55. The main spool is forced forward by the oil pressure (2.2 MPa) and at the same time, the return spring is compressed. When the force of the return spring balances the armature force, the servo spool closes the pressure port in the positioner and the main spool ceases to move. This enables a predetermined current to be converted to a proportional spool position in the valve by means of the armature force and a return spring. The angular deflection of the controller's control lever orders the positioner to a certain position. This position is not influenced by flow included forces, spring pressure, friction forces on the valve spool, or by the pressure of the oil supply to the positioner. The positioner is carefully calibrated to enable a current of 200 mA to always give a deflection of 2 mm, and a current of 460 mA to give a deflection of 7 mm.

### Pressure Reduction Filter

56. The function of the pressure reduction filter is to supply the positioners of the remote control system with filtered oil at a working pressure of approximately 2.2 MPa. The filter is mounted on the left-hand slew cylinder, adjacent to the main control valve.

### Remote Control Hydraulic System

57. A dump valve (Figure 10, Item 1) in the valve block is controlled by the solenoid valve (Figure 10, Item 2). When 24 V dc is applied to the solenoid, it closes. The spring housing on the dump valve is then supplied with full pressure through a restriction in the dump valve piston. The dump valve spring closes the dump piston. When the voltage in the solenoid valve is removed, the spring housing is drained and the dump valve opens.

### NOTE

This is an important safety function in the system.

58. The pressure reduction filter (Figure 10, Items 3 and 4) is fed from the pump line and supplies oil at a pressure of 22 bar to the positioners.

**NOTE**

A clogged or partially clogged filter will cause a deterioration of operational efficiency as the oil filter does not have a bypass valve.

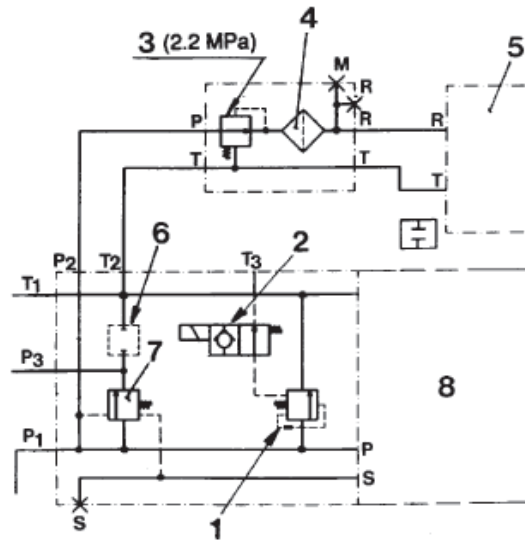

- |                         |                          |
|-------------------------|--------------------------|
| 1 Dump valve            | 5 Positioner             |
| 2 Solenoid valve/plug   | 6 Serial connection plug |
| 3 Pressure reducer      | 7 Shunt valve            |
| 4 Filter 10 μm absolute | 8 Control valve          |

**Figure 10 Remote Control Hydraulic Circuit**

**SAFETY PROTECTION AND CONTROL EQUIPMENT**

**59.** The safety protection and control equipment fitted to the crane provides crane OLP, an automatic oil dumping function, that helps reduce the temperature of the hydraulic oil, and an inner boom height warning function.

**Overload Protection**

**60.** The OLP system warns the operator when 90% of the crane’s capacity is reached. When maximum capacity is reached, the OLP system stops all movements that could increase the crane’s loading.

**61.** The triangle on the power supply box (PSBI) blinks when the pressure in the inner or outer boom cylinders reaches 90% of the permitted pressure. At 100% the OLP cuts in, stopping load increasing movements. The triangle has a steady light until the overload situation is rectified.

**62.** To correct an OLP situation, the RELEASE button is pressed, (Figure 12, Item 2 and Figure 8, Item 7 if using the remote controller) while moving one control lever in the direction that will reduce the load. The triangle (Figure 12, Item 3) will illuminate in a circulating pattern. There is a 5 second time period in which to correct the OLP situation. There is a waiting time of 30 seconds before the release operation can be attempted again.

**NOTE**

In most cases, the OLP condition can be overcome without use of the release button by simply lowering the inner boom or reducing the load moment by any other means.

**Automatic Dumping Function (ADO)**

**63.** When the crane has not been operated for a few seconds, the safety control system opens the dump valve. This allows the oil to return directly to the tank, helping to keep the hydraulic oil temperature down. As soon as the operator moves a lever, the dump valve closes.

UNCONTROLLED IF PRINTED

### Height Warning – Inner Boom

64. This function warns the operator (via a red lamp in the cabin) if, for some reason, the operator attempts to drive the truck with the boom system pointing upwards.
65. The high boom warning lamp in the cabin also lights at all times when the crane's SPACE system is switched on. The SPACE system will automatically switch off after 30 minutes of inactivity.

### System Components

66. The SPACE system consists of the following components (Figure 11):
- a. a microprocessor box (SPACE box);
  - b. a power supply box (PSBI);
  - c. a main power connection box (MPCB);
  - d. a column box;
  - e. spool sensors;
  - f. pressure sensors;
  - g. tilt indicators;
  - h. a dump valve; and
  - i. a diagnostic terminal connection.

### Microprocessor Box (SPACE Box)

67. The SPACE box contains a microprocessor which receives signals from the crane's various sensors and indicators regarding the crane's load, position and movements. The microprocessor then controls parameters of crane operation by preventing or reducing invalid movements or speeds by changing signals to the DA modules.

### Power Supply Box (PSBI)

68. A PSBI box is fitted at the main operator station. It contains a selector for remote and manual control. The main power supply is connected to the MPCB, shown in Figure 11, and distributed to appropriate components in the system. The buttons and lamps fitted to the PSBI box are shown in Figure 12.

69. The function of each button and indicator lamp is as follows (Figure 12):
- a. **Release Lamp.** The release lamp is lit when the OLP system has been disengaged via the release button.
  - b. **Release Button.** The release button is used to switch the automatic dump function on or off and to disengage the OLP function in certain overload situations.
  - c. **Warning Triangle of Lamps.** The warning triangle of lamps blinks at a rate of once per second or 1 Hz at 90% load. It is lit when the crane is overloaded. It blinks in a circulating pattern when the OLP function is disengaged via the Release button. When the inner boom height warning is activated and the system is switched off, the triangle blinks for five minutes.
  - d. **Stop Button.** The stop button is used to terminate crane functions by cutting power to the dump valve (all hydraulic pump flow is diverted back to the reservoir). The button must be turned clockwise to reset it.

### NOTE

The stop button must always be pressed in when powering up the system.

- e. **Fault Lamp.** The fault lamp blinks at 3 Hz when SPACE indicates a fault (digital indicator) and flashes at 1 Hz when the system is turned off but 24 V dc power is available via the lamp kit.
- f. **Oil 1 Lamp.** The oil 1 lamp is lit when the stop button is pulled out and power to the dump valve is supplied by the PSBI.

UNCONTROLLED IF PRINTED

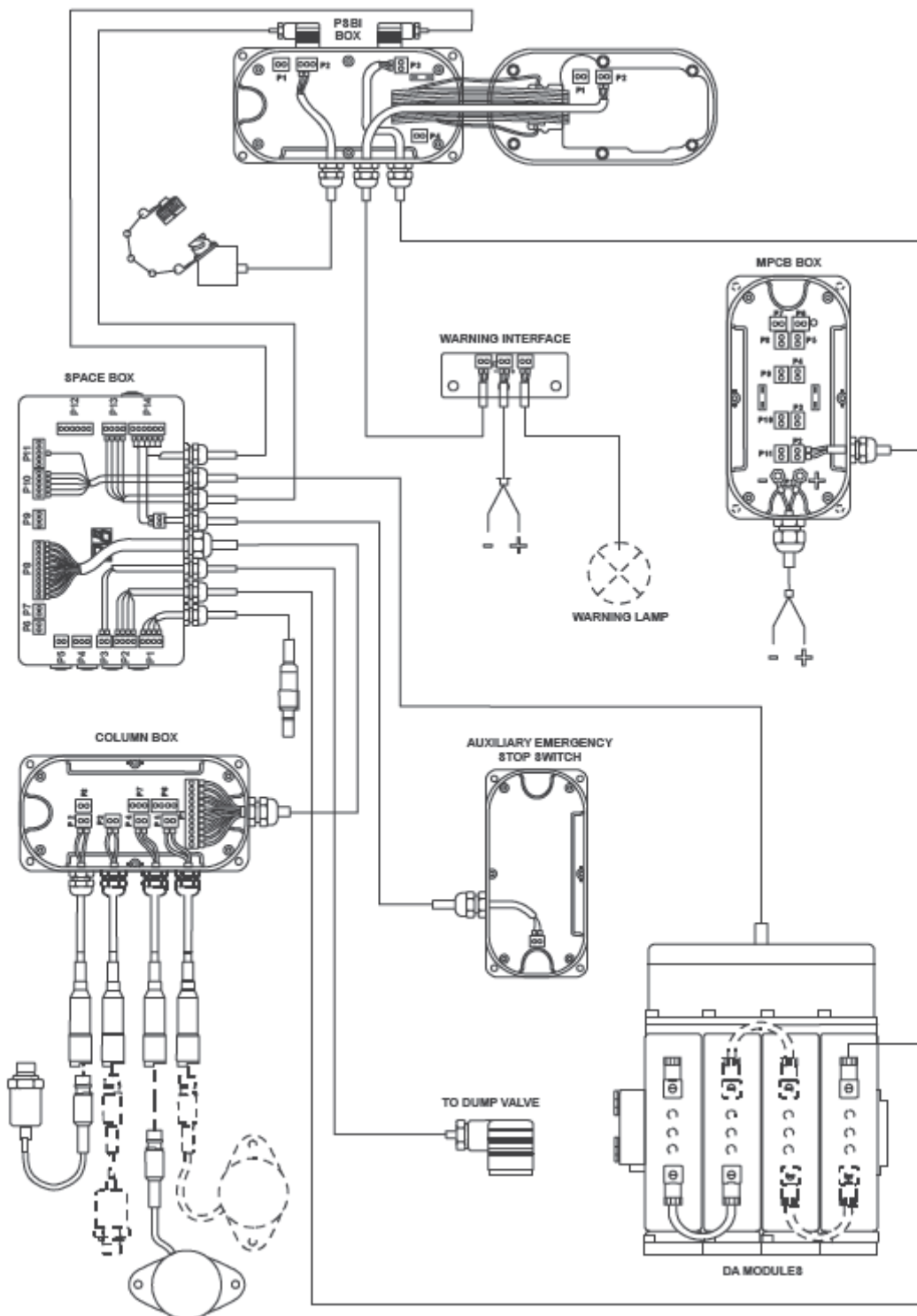
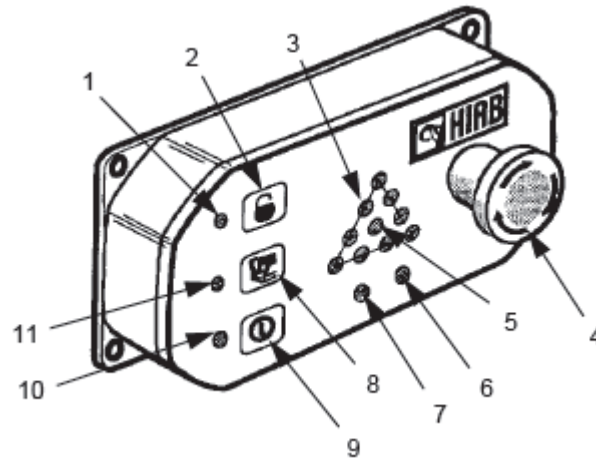

Figure 11 SPACE Components



- |   |                        |    |                      |
|---|------------------------|----|----------------------|
| 1 | Release lamp           | 7  | Oil 1 10 amp         |
| 2 | Release button         | 8  | Remote/manual button |
| 3 | Warning triangle lamps | 9  | On/Off button        |
| 4 | Stop button            | 10 | On lamp              |
| 5 | Fault lamp             | 11 | Remote lamp          |
| 6 | Oil 2 lamp             |    |                      |

**Figure 12 PSBI Box**

- g. **Oil 2 Lamp.** The oil 2 lamp is lit when the stop button is pulled out and SPACE sends a signal confirming power to the dump valve and flashes at 1 Hz when a connection with SPACE is broken (eg open circuit).
- h. **Remote/Manual Button.** The remote/manual button is used to switch between manual and remote operating modes.
- i. **On/Off Button.** The system is switched on by momentarily pressing the On/Off button. The system is switched off by momentarily re-pressing the button.
- j. **On Lamp.** The On lamp is lit when the system is switched on.
- k. **Remote Lamp.** The remote lamp is lit when the system is in the remote control mode and flashes at 1 Hz when no signals are received by SPACE.
- l. **Indicator Lamp.** The indicator lamp located inside the box blinks at 1 Hz when remote control is engaged but no protocol arrives and flashes at 1 Hz when the stop button is pressed. The lamp also flashes at 2 Hz when the stop button is pulled out and the system is in the manual operating mode.
- m. **Fuse.** A 7.5 A automotive type fuse is located inside the PSBI.

**Main Power Connection Box (MPCB)**

70. A MPCB box (Figure 11) is mounted below the PSBI box and is used to distribute 24 V dc power to different boxes and components within the system. There are two separate circuits each protected by a 15 A fuse. The SPACE system is connected to one of the circuits while other electrical components are connected to the second circuit.

**Column Box**

71. Data from pressure sensors and indicators on the boom system are assembled in the column box on the crane body. A cable with several leads interfaces this box to the SPACE box.

**Sensors and Indicators**

- 72. The following describes the various functions of the sensors and indicators located on the crane system:
  - a. **Spool Sensors.** Spool sensors are fitted above the main control valve positioners and register the position of the control valve spools.
  - b. **Pressure Sensors.** These analogue sensors, fitted to the load holding valves of the inner and outer boom cylinders, provide continuous information regarding the pressure in the respective cylinder.

UNCONTROLLED IF PRINTED



- c. Tilt Indicators.** Tilt indicators are fitted to show the position of the crane as follows:
- (1) Tilt Indicator (Outer Boom).** The outer boom tilt indicator is a part of the OLP and registers the outer boom tilt upward or downward from the horizontal position. An imaginary line between the indicator's two fixing points should be parallel to the outer boom. The indicator is marked with an arrow on the mounting face pointing to the crane's outer end.
  - (2) Tilt Indicator (Inner Boom).** The inner boom tilt indicator is mounted on an adjustable plate fitted to the inner boom and registers the height of the inner boom for the high boom warning feature.

### Dump Valve

**73.** The dump valve, fitted to the main control valve, controls the oil flow. When the valve is active, oil is directed to the control valve. When the valve is inactive (without power), the flow stops and all crane functions stop. The dump valve is controlled from the microprocessor box; consequently, when an emergency stop button is pressed, power to the dump valve is cut, stopping all crane functions.

### Diagnostic Terminal

**74.** A laptop computer, loaded with the appropriate software, can be used to access or monitor the different SPACE functions including checking or setting system parameters and conducting general troubleshooting operations. An interface cable is required to allow communication and is connected between the laptop computer and the SPACE box diagnostic terminal. A password and identification code are required to be entered before any access to the SPACE system is allowed. There are two levels of access. The first level is assigned to service personnel and the second to Hiab system specialists. The identification code and password assign the operator's access level.

### Bar Codes

**75.** Almost all SPACE components are marked with bar codes. The bar codes identify the name or abbreviation, part number, serial number and sub-supplier of the component or box. Bar codes are located on the inside and outside of the boxes.

### Wiring Connections

**76.** The wiring connections for the SPACE components on the crane are shown in Figure 11.

### HYDRAULIC SYSTEM

- 77.** The hydraulic system consists of the following main components:
- a.** a power take-off (PTO);
  - b.** a hydraulic pump;
  - c.** a main control valve;
  - d.** an outrigger control valve;
  - e.** load holding valves;
  - f.** a sequencing valve;
  - g.** an outrigger leg check valve;
  - h.** an inline restrictor valve;
  - i.** a hose rupture valve;
  - j.** operating cylinders;
  - k.** an oil tank;
  - l.** a return oil filter; and
  - m.** an oil cooler.

### Power Take Off (PTO)

78. A mechanically driven Powauto AH23BR11 single-speed PTO is mounted on the right-hand side of the vehicle transmission. The PTO is pneumatically actuated and is controlled by the PTO ON/OFF switch mounted on the vehicle dashboard. When this switch is placed in the ON position, compressed air is directed to the PTO selector mechanism, actuating a gear selector fork. The fork engages the appropriate drive gears to transfer drive from the transmission to the PTO hydraulic pump. The PTO is lubricated by oil from the vehicle transmission.

### Hydraulic Pump

79. The PZB XP36 hydraulic pump is flange mounted via an adaptor onto the drive output end of the PTO. The pump is a two-gear, constant displacement design, which draws hydraulic fluid from the reservoir and provides pressurised hydraulic fluid to the crane controls.

80. When the pump is being driven, hydraulic fluid is drawn from the reservoir through the pump inlet port. The rotation of the gears forces the fluid through the outlet port under pressure. The hydraulic oil passing through the pump also lubricates the working components.

### Main Control Valve

81. The main control valve (spool valve) is mounted on the left-hand side of the vehicle at the operator's station. It is an open centre valve system which features a dump valve and spool position sensors. The valve section has no load holding function as this is placed separately at the cylinders. The valve consists of a bank of six spools which control the slew, inner boom, outer boom, boom extension and tilt functions of the crane. One spool is not used.

82. The valve can be operated manually from either side of the vehicle or can be controlled using the Combidrive remote controller. DA modules and spool positioners are fitted to enable remote operation.

### Outrigger Control Valve

83. The outrigger control valve (spool valve) is mounted to the right side of the operator's station. The valve consists of a bank of four spools which control the left and right outrigger extensions and stabiliser legs. The valve is operated manually, using the two levers fitted to the valve for the left side of the vehicle and two cable-operated remote levers for the right side of the vehicle.

### Load Holding Valves

84. Load-holding valves (LHV) are employed on the inner and outer boom cylinders and on the boom extension cylinder to ensure that the boom does not creep under load. In addition, they protect the system in the event of a hose failure. The boom cannot be lowered or the extension extended without pump pressure.

85. The inner and outer boom LHV are fitted with overload protection pressure sensors which relay data to the SPACE system to protect against overloading the crane.

### Sequencing Valve

86. A sequencing valve (Figure 13) is located on the boom extension cylinder to ensure that the boom extensions extend in the correct sequence. The return oil flow from the inner piston is restricted by the sequencing valve, forcing the outer piston to extend first. Once the outer piston is fully extended, the sequencing valve opens under increased pressure and allows the inner piston to extend.

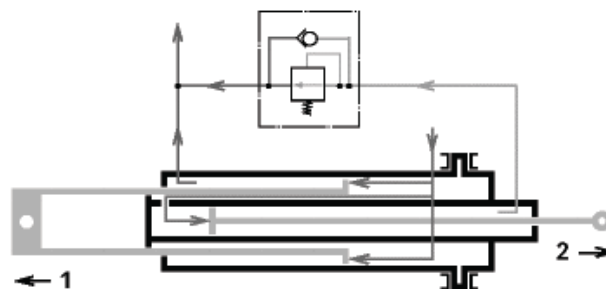

Figure 13 Sequencing Valve

UNCONTROLLED IF PRINTED

### Outrigger Leg Check Valve

87. A pilot-operated check valve is located on the outrigger leg cylinder and is used to prevent the support leg from collapsing under load. It is achieved by preventing the oil on the piston side of the cylinder from escaping without pilot pressure to lift the check ball from its seat. Pilot pressure only exists when the operator intentionally retracts the leg (Figure 14).

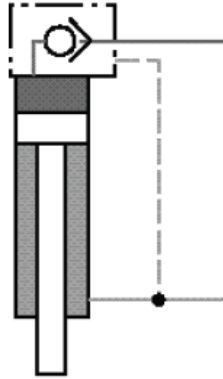

Figure 14 Outrigger Leg Check Valve

### Inline Restrictor Valve

88. An inline restriction valve is fitted to the tilt circuit to regulate the speed of the tilting operation. The valve restricts the flow of oil in both directions, but more so in one direction than the other. The valve is installed so that the return oil path has a restriction greater than that from the main control valve (Figure 15).

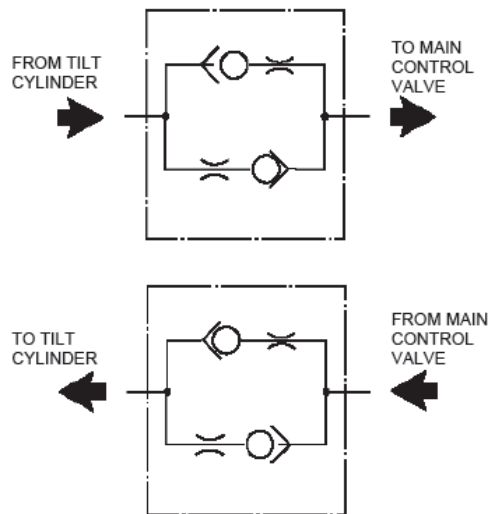

Figure 15 Inline Restrictor Valve

### Hose Rupture Valve

89. A hose rupture valve is incorporated in the tilt circuit to protect the system in the event of a hose failure. The valve is flow-controlled and acts as a safety valve if a hose fails. The valve has a built-in pressure relief function that provides a damping effect to stop movement. The oil is free to flow through the valve as long as the thrust of the spring is strong enough to hold it open.

90. In the event of a hose failure, the pressure drops rapidly and the speed of flow of the oil forces the poppet down onto its seat. An over-pressure arises when the poppet closes, but the ball rises from its seat and allows it to drain away providing a damping effect. The ball then closes which ensures the valve is tight (Figure 16).

UNCONTROLLED IF PRINTED

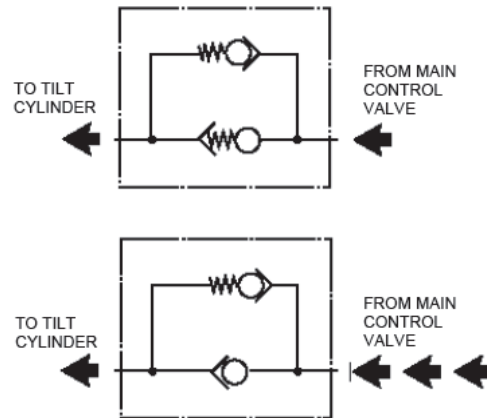

Figure 16 Hose Rupture Valve

### Oil Tank and Return Filter

91. The steel constructed oil tank is mounted at the rear of the cab on the driver's side and has a capacity of 105 litres. The tank is fitted with sight and temperature gauges to monitor the level and temperature of the hydraulic oil, a return line oil filter mounted in the top of the tank and an air filter and fouling indicator incorporated in the filler cap.

### Oil Cooler

92. The oil cooler is mounted beneath the tray adjacent to the oil tank and is fitted with a thermostatically controlled fan used to control the hydraulic oil temperature within an acceptable operating range. It also incorporates a soft start mechanism to reduce the current draw when the cooler fan starts.

### HYDRAULIC CIRCUITS

93. Paras 94 to 112 describe the main hydraulic circuits of the Hiab 090 AW crane. The hydraulic circuit diagram is shown in Figure 17.

### Inner and Outer Boom

94. The hydraulic circuits for the inner and outer booms are identical and comprise the main control valve, a load holding valve, the boom cylinder and a one-way restriction valve.

95. When the control lever is moved up (or away from the operator on the Combidrive), pressurised oil is directed to the boom cylinder's LHV check valve. The check valve is lifted off its seat, allowing oil to pass through the relief valve and on to the piston side of the boom cylinder. Pressurised oil actuates the piston thereby raising the boom. The displaced oil on the piston rod side of the cylinder returns through the one-way restriction valve, via the spool, to the return channel. The LHV prevents the crane boom from sinking. The boom cannot be lowered without pump pressure.

96. When the control lever is released and allowed to return to its central position, the control valve is closed and all fluid flow within the circuit is checked. The piston will now remain rigidly in place.

97. When the control lever is moved down (or toward the operator on the Combidrive), pressurised oil is carried by a separate line to the piston rod side of the cylinder. The return oil from the piston side of the cylinder is stopped by the check valve in the LHV. A pressure build up takes place causing the pilot piston to open the passage to the tank by lifting the poppet in the relief valve.

UNCONTROLLED IF PRINTED

UNCONTROLLED IF PRINTED

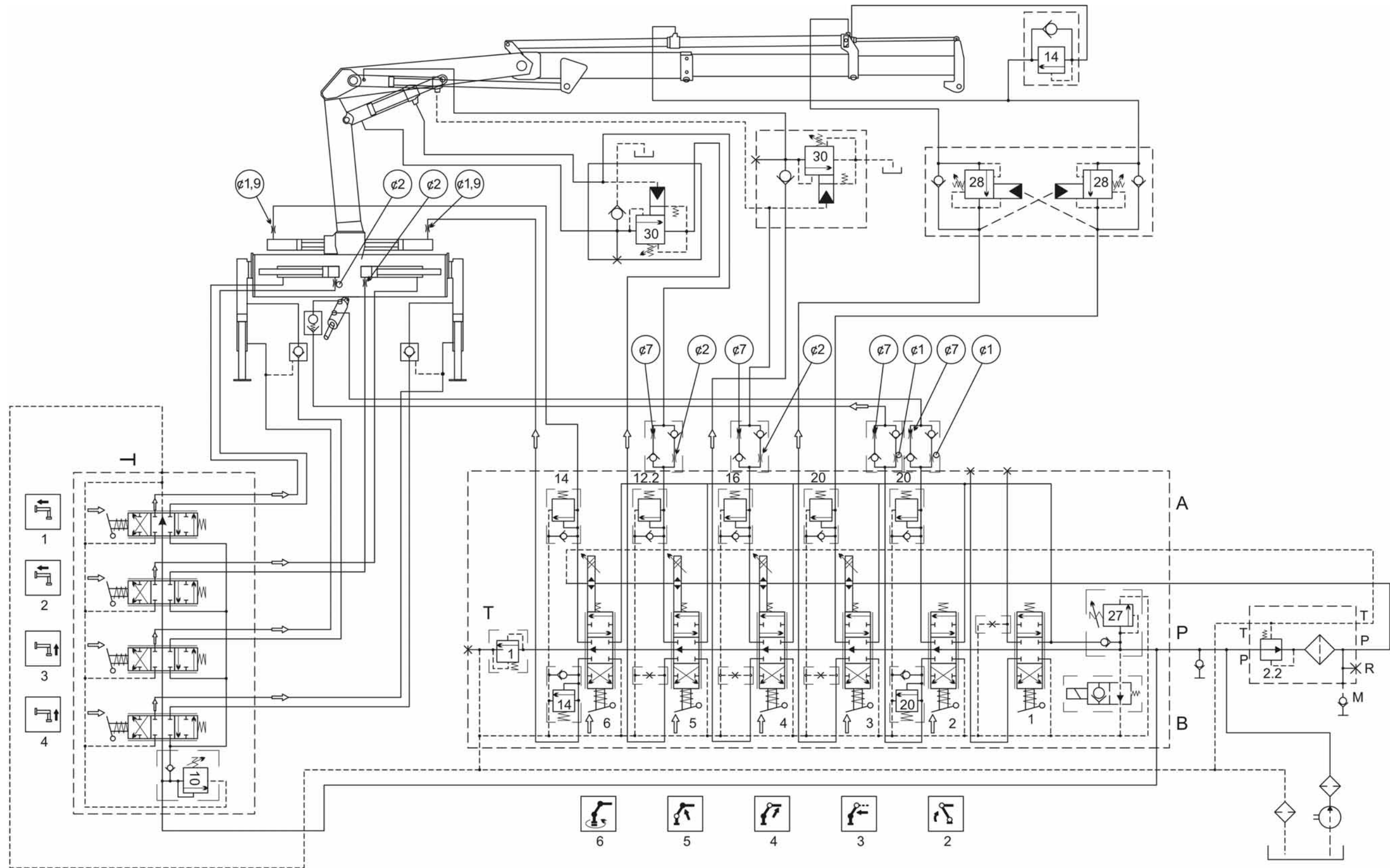

DE(EME)3542-1

Figure 17 Hydraulic Circuit Diagram

UNCONTROLLED IF PRINTED

**Blank Page**

### Boom Extensions

98. The hydraulic circuit for the boom extension comprises the main control valve, a load holding valve, a sequencing valve and the extension cylinder. This duplex cylinder, detailed in Para 25, consists of an outer and an inner piston. The outer piston (larger piston rod) is intended to extend first and retract last.

99. When the control lever is moved up (or away from the operator on the Combdrive), pressurised oil acts concurrently on the outer and inner pistons. The return oil flow from the inner piston is restricted by a sequencing valve, forcing the outer piston to extend first. Once the outer piston is fully extended, the sequencing valve opens under increased pressure and allows the inner piston to extend. A load holding valve is mounted on the cylinder to prevent the load from affecting the boom (retracting or extending) when the hydraulic system is inactive (Figure 18).

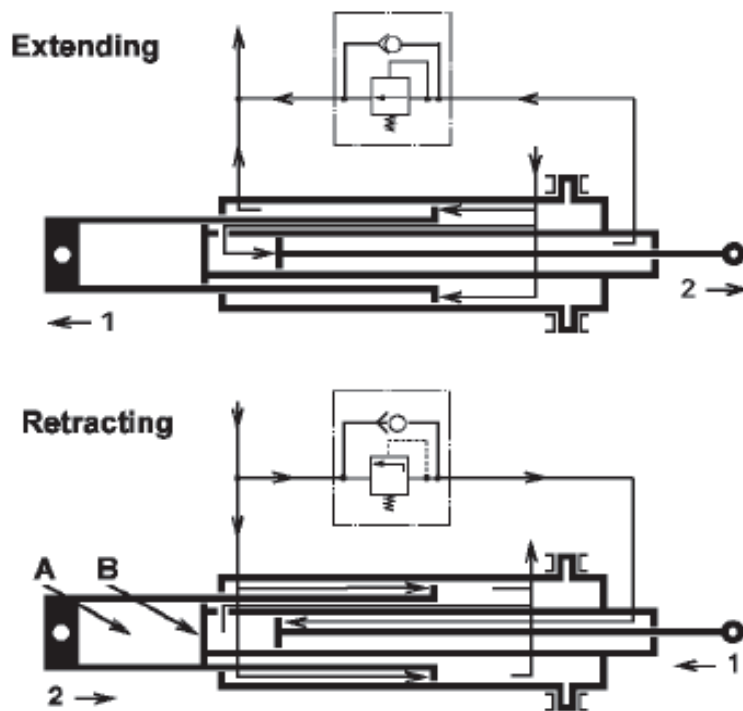

Figure 18 Boom Extension Cylinder Operation

100. When the control lever is moved down (or toward the operator on the Combdrive), the pressurised oil (through two connections) actuates the outer and inner pistons at the same time. The inner piston retracts first, due to its larger area, after which the outer piston retracts. In Figure 18, a check valve (B) is included in order to drain space (A) in the event of a leakage across the seal of the outer piston. When the cylinder is all but fully retracted, any leakage oil that may be present is forced to the return line via the check valve.

### Slew

101. The hydraulic circuit for the slew function comprises the main control valve, restriction valves and the slew cylinder (Figure 17).

102. When the control lever is moved up (or away from the operator on the Combdrive), the crane body slews in a clockwise direction as oil under pressure is directed via the control valve and the one-way restriction valve to the slew cylinder (Figure 19). Displaced oil is flow limited in the one-way restriction valve before it returns to the tank channel under return pressure. When slewing downhill the slew cylinder can never be emptied quicker than oil is being replenished on the opposite side because of the separate load holding function which prevents hydraulic play. It is not possible to slew without pump pressure.

103. When the control lever is moved down (or toward the operator on the Combdrive), the crane body slews in a counterclockwise direction as oil under pressure is directed via the control valve and the one-way restriction valve to the left side of the slew cylinder. Displaced oil is flow limited in the one-way restriction valve before it returns to the tank channel under return pressure. Para 96 details the operation of the hydraulic circuit when the control lever is released.

UNCONTROLLED IF PRINTED

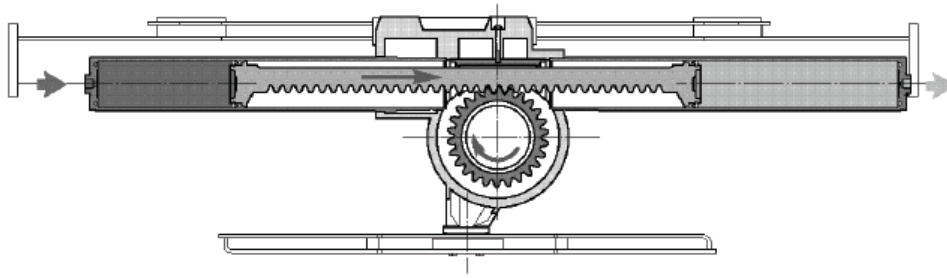

Figure 19 Slew Cylinder Operation

### Tilt

**104.** The hydraulic circuit for the tilt function comprises the main control valve, a hose rupture valve, an inline restrictor and the tilt cylinder.

**105.** When the control lever is moved up (or away from the operator on the Combidrive), pressurised oil is directed to the piston side of the tilt cylinder via the inline restrictor. This actuates the piston which lowers the crane toward the vehicle rear tray. Displaced oil on the piston rod side of the cylinder returns to the spool via the inline restrictor then to the tank return channel.

**106.** When the control lever is moved down (or toward the operator on the Combidrive), pressurised oil is directed to the piston rod side of the tilt cylinder via the inline restrictor. This actuates the underside of the piston which raises the crane from the vehicle rear tray. Displaced oil on the piston side of the cylinder returns to the spool via the inline restrictor then to the tank return channel. Para 96 details the operation of the hydraulic circuit when the control lever is released.

### Outrigger Extensions

**107.** The hydraulic circuit for the outrigger extension comprises the outrigger control valve and the outrigger extension cylinder.

**108.** When the control lever is moved to the left, pressurised oil is directed to the piston side of the outrigger extension cylinder. This actuates the piston which extends the outrigger extension. Displaced oil on the piston rod side of the cylinder returns to the outrigger spool valve then to the tank via the return channel.

**109.** When the control lever is moved to the right, pressurised oil is directed to the piston rod side of the outrigger extension cylinder. This actuates the underside of the piston which retracts the outrigger extension. Displaced oil on the piston side of the cylinder returns to the outrigger spool valve then to the tank via the return channel. Para 96 details the operation of the hydraulic circuit when the control lever is released.

### Outrigger Leg

**110.** The hydraulic circuit for the outrigger leg comprises the outrigger control valve, a pilot controlled check valve and the outrigger leg cylinder.

**111.** When the control lever is moved to the left, pressurised oil lifts the check valve off its seat and passes through to the piston side of the outrigger leg cylinder. This actuates the piston which extends the outrigger leg. Displaced oil on the piston rod side of the cylinder returns to the outrigger spool valve then to the tank via the return channel. The pilot operated check valve prevents oil from escaping from the piston side of the cylinder, ensuring that the cylinder cannot collapse under load.

**112.** When the control lever is moved to the right, pressurised oil is directed to the piston rod side of the outrigger leg cylinder. No movement can take place in the cylinder because the pilot operated check valve prevents oil on the piston side of the cylinder from returning to the tank. When sufficient oil pressure is built up in the pilot line to overcome spring pressure and open the check valve, it actuates the underside of the piston which retracts the outrigger leg. The displaced oil on the piston side of the cylinder returns, via the check valve, to the outrigger spool valve then to the tank via the return channel. Para 96 details the operation of the hydraulic circuit when the control lever is released.

UNCONTROLLED IF PRINTED



**WIRING HARNESS**

113. Figures 20, 21 and 22 illustrate the wiring harnesses for the vehicle.

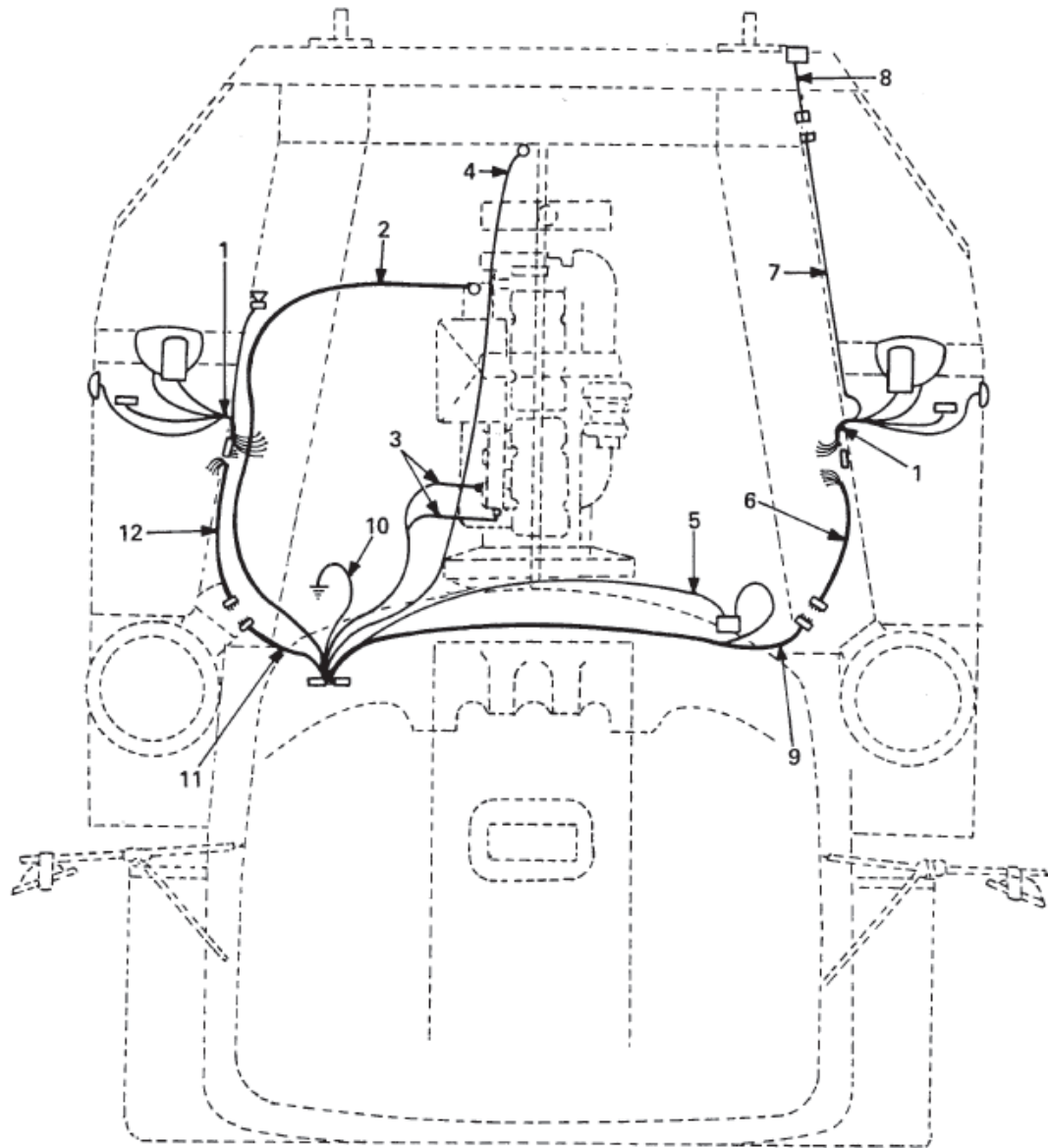

- |   |                                 |    |  |
|---|---------------------------------|----|--|
| 1 | Front lights and horn           | 7  | Reduced head light loom                |
| 2 | Generator                       | 8  | Reduced head light                     |
| 3 | Water temperature alarm         | 9  | Cab to right-hand mudguard wiring loom |
| 4 | Low water level                 | 10 | Cab to chassis (earth)                 |
| 5 | Stop lamp                       | 11 | Cab to left-hand mudguard wiring loom  |
| 6 | Right-hand mudguard wiring loom | 12 | Left-hand mudguard wiring loom         |

**Figure 20 Front Wiring Harness**

UNCONTROLLED IF PRINTED

UNCONTROLLED IF PRINTED

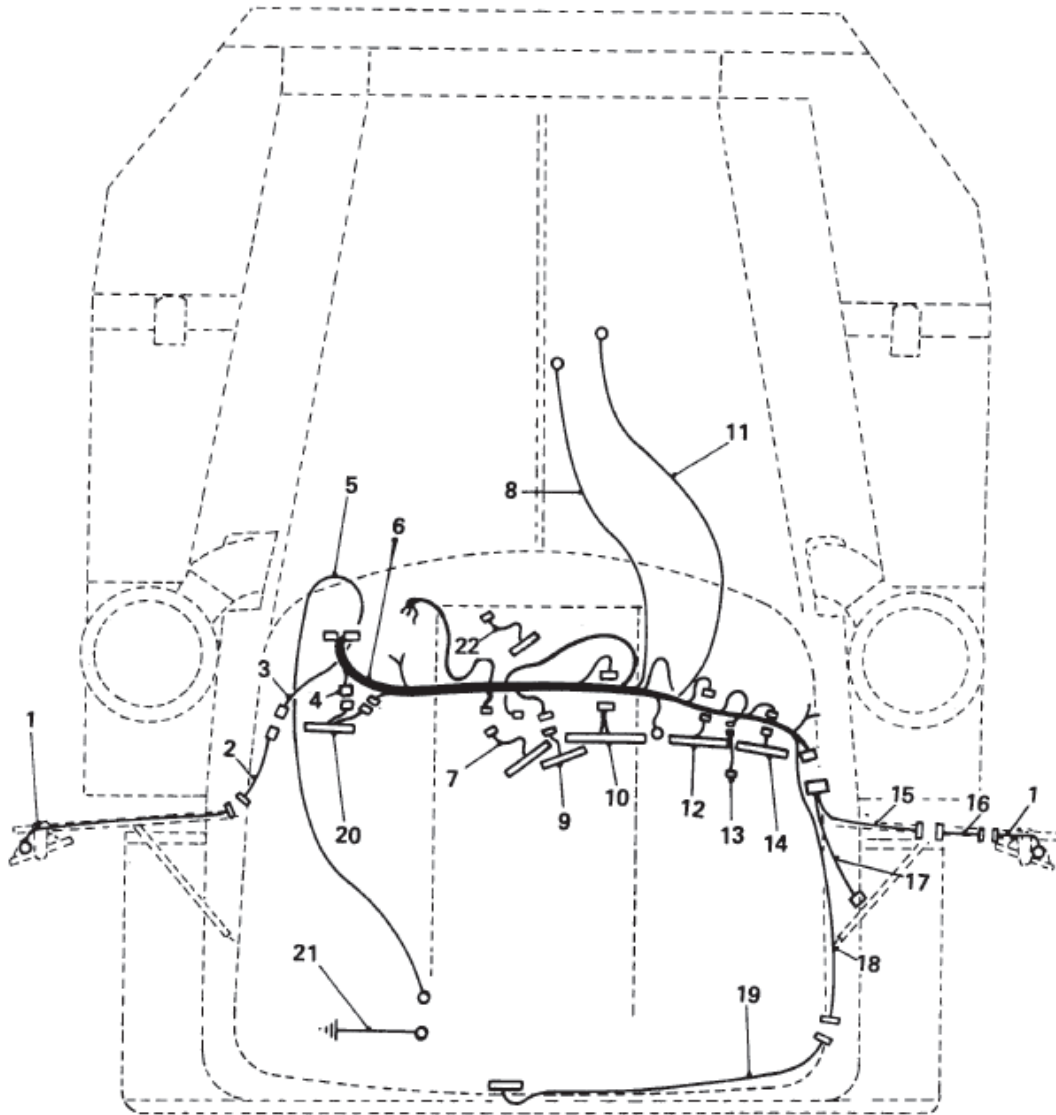

- |    |                                  |    |                                  |
|----|----------------------------------|----|----------------------------------|
| 1  | Mirror lamps                     | 12 | Panel speedometer                |
| 2  | Mirror lamp extension left-hand  | 13 | Steering column                  |
| 3  | Mirror lamp left-hand loom       | 14 | Upper console right-hand panel   |
| 4  | Kysor board to plug to peg board | 15 | Mirror lamp extension right-hand |
| 5  | Reverse lamp                     | 16 | Mirror lamp right-hand loom      |
| 6  | Main cab                         | 17 | Windshield washer                |
| 7  | Left-hand panel                  | 18 | Roof                             |
| 8  | Pyrometer to sender              | 19 | Roof                             |
| 9  | Right-hand Panel                 | 20 | Kysor panel main loom to fuses   |
| 10 | Pyro panel to plug               | 21 | Chassis to gearbox (earth)       |
| 11 | Dynatard                         | 22 | High boom warning lamp           |

Figure 21 Cab Wiring Harness

UNCONTROLLED IF PRINTED

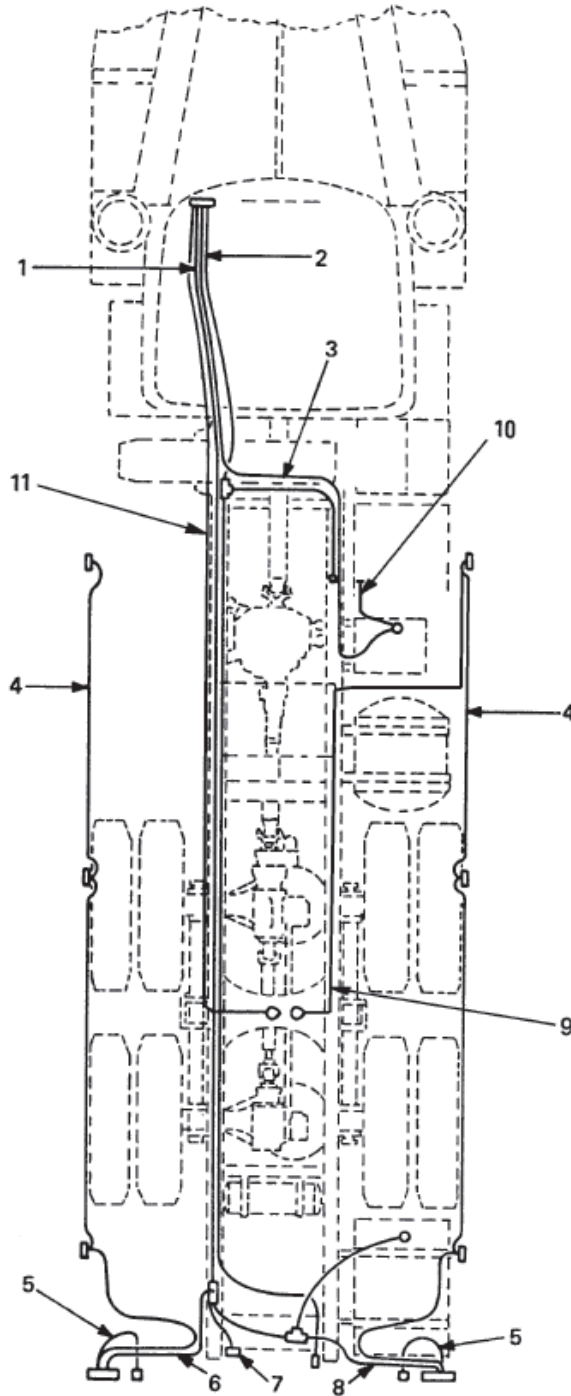

- |                         |                          |
|-------------------------|--------------------------|
| 1 Main chassis          | 7 12-pin NATO socket     |
| 2 Auxiliary chassis     | 8 Right-hand tail lights |
| 3 Battery               | 9 Work lamp              |
| 4 Side marker lamps     | 10 Oil cooler            |
| 5 Blackout lamps        | 11 High boom warning     |
| 6 Left-hand tail lights |                          |

**Figure 22 Rear Wiring Harness**

**114.** Table 1 details the location of the vehicle component identification numbers.

**Table 1 Location of Identification Numbers**

<b>Serial</b>	<b>Item</b>	<b>Location</b>
1	Chassis number	Right-hand rear frame, above intermediate axle
2	Chassis nameplate	Left-hand door, inside cab
3	Engine number	Right-hand top of timing gear housing
4	Front axle number	Left rear of axle housing
5	Transmission number	Left-hand side
6	Transfer case	Right-hand side
7	Intermediate axle number	Right-hand front of carrier housing
8	Rear axle number	Right-hand front of carrier housing
9	Injection pump identification	Side of the pump
10	Crane	On the crane body
11	Power take off (hydraulic pump)	Right-hand side
12	Hydraulic pump	Rear face of the pump
13	Cab upper section	Rear inner left-hand panel
14	Cab lower section	Left-hand door opening gusset

UNCONTROLLED IF PRINTED

**END**

Distribution List: **VEH G 52.0 – Code 1** (Maint Level)  
(Sponsor: LV SPO, Mdm/Hvy B Vehicles Section)  
(Authority: ECO LVSP0035/08)