

## TRUCK, CARGO, MEDIUM, CRANE, MC2 - UNIMOG

### MEDIUM GRADE REPAIR

This instruction is authorised for use by command of the Chief of Army. It provides direction, mandatory controls and procedures for the operation, maintenance and support of equipment. Personnel are to carry out any action required by this instruction in accordance with EMEI General A 001.

#### INTRODUCTION

1. This instruction details all the Medium Grades of Repair procedures for the Truck, Cargo, Medium, Crane, MC2.

#### Associated Publications

2. Reference may be necessary to the latest issue of the following documents:
  - a. [AS 1418.5](#), Cranes, hoists and winches – Mobile cranes;
  - b. [AS 2550.11](#), Cranes, hoists and winches – Safe use – Vehicle-loading cranes;
  - c. EMEI Vehicle G 60 Decade, Truck Cargo Medium MC2 - Unimog;
  - d. EMEI Vehicle G 62 Decade, Truck Cargo Medium Crane MC2 - Unimog;
  - e. [EMEI Workshop H 108-1](#), Cranes and Winches;
  - f. [RPS 02157](#) and [02155](#); and
  - g. [SCES 11756](#).

#### Precautions

3. Observe the following precautions before carrying out Medium Grade Repairs:



**Do not start the engine whilst repair procedures are carried out on the crane system components.**

- a. Adhere to the instructions detailed in EMEI Workshop H 108-1.
- b. To prevent dirt, dust and foreign matter from entering or adhering to any component, maintain a high standard of cleanliness. Cap all disconnected hoses and lines with plastic caps.

A rectangular sign with a thick black border containing the word "WARNING" in bold, uppercase letters.

**WARNING**

**Before working on the hydraulic system, ensure that the hydraulic fluid is sufficiently cool to avoid burns.**

- c. Discard all used seals, O rings, cotter pins, washers, and lockpins. Discard any hydraulic oil drained from components.

## MEDIUM GRADE REPAIR

### Access for Repair



**Before raising the crane ensure that the parking brake is applied and the wheels are chocked at the front and rear of the truck.**

4. If the diverter valve requires repair, access to the valve is gained from underneath the front of the truck. To inspect the directional control valve bank it is necessary to un-stow the crane. If, due to hydraulic failure, it becomes necessary to raise the crane, overhead lifting facilities and lifting tackle with a greater safe working load than 1 tonne must be used. The crane must only be lifted by the welded lugs on the outer boom.

### Hydraulic Oil Pump

5. **Removal.** Remove the hydraulic oil pump from the engine in accordance with EMEI Vehicle G 623.
6. **Repair.** Repair the hydraulic oil pump as follows (Figure 1):

#### NOTE

To prevent oil spillages during disassembly place the pump in a drip tray.

- a. Using a suitable hex drive key, remove the bolts (Figure 1, item 9) and lock washers (Item 8) attaching the cover (Item 3) to the pump body (Item 10).
- b. Separate the cover and pump body.
- c. Lift out the thrust plate (Item 7) from the cover. Remove and discard the seal spring (Item 6), seal (Item 5), O ring (Item 4), circlip (Item 1) and gasket (Item 2).
- d. Remove the rod (Item 15) from the sealing segment (Item 14).
- e. Remove the positioning pin (Item 16).

#### NOTE

Use long nose pliers, to compress the sealing segment (Item 14) and prevent loss of internal springs and balls.

- f. Withdraw the pump shaft (Item 18) and sealing segment (Item 14).
- g. Remove the internal ring gear (Item 17).
- h. Remove the thrust plate (Item 13).
- i. Remove and discard the seal spring (Item 12) and seal (Item 11) from the pump body.
- j. Inspect the pump parts and body for wear and damage. Replace any worn or damaged items.
- k. Install the new seal (Item 11) and secure it with the spring (Item 12) into the pump body (Item 10). Install the thrust plate (Item 13).
- l. Insert the internal ring gear (Item 17) and pump shaft (Item 18).
- m. Install the positioning pin (Item 16) to engage in the thrust plate (Item 13).
- n. Insert the sealing segment (Item 14) between the pump shaft and the internal ring gear.
- o. Install the thrust plate (Item 13) over the positioning pin.
- p. Insert the rod (Item 15) to retain the sealing segment (Item 14).
- q. Fit the new O ring (Item 4) and the seal (Item 5) and retain it with the spring (Item 6).
- r. Insert the new gasket (Item 2) and retain it in the cover with the circlip (Item 1).

- s. Align the cover (Item 3) and pump body (Item 10) and secure it with the lock washers (Item 8) and bolts (Item 9). Tighten the bolts to 80 N.m.

**Table 1 Annotation to Figure 1**

Item	Description	Item	Description	Item	Description	Item	Description
1	Circlip	6	Seal spring	11	Seal	16	Positioning pin
2	Gasket	7	Thrust plate	12	Seal spring	17	Internal ring gear
3	Pump cover	8	Lock washer	13	Thrust plate	18	Pump shaft
4	O ring	9	Cover bolt	14	Sealing segment		
5	Seal	10	Pump body	15	Rod		

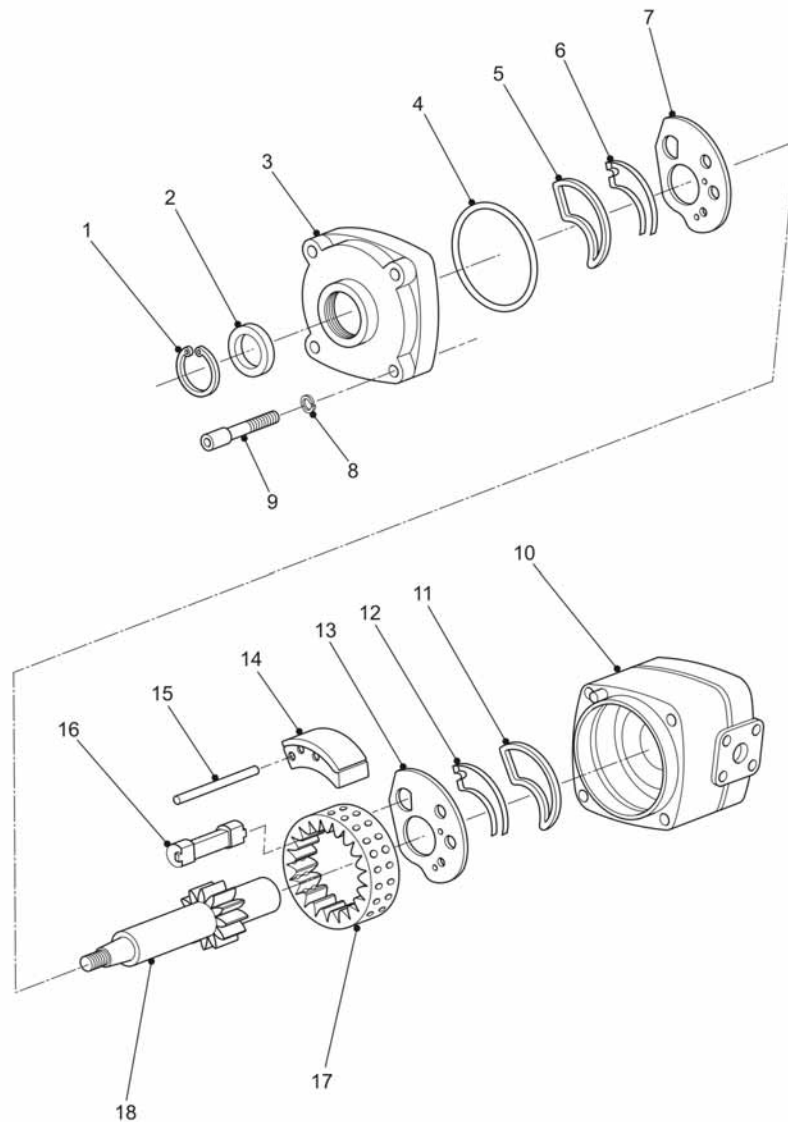

**Figure 1 Hydraulic Oil Pump Components**

- 7. **Installation.** Install the hydraulic oil pump in accordance with EMEI Vehicle G 623.

**Diverter Valve**

- 8. **Removal.** Remove the diverter valve complete with solenoid. Do not remove the adapter from the mounting bracket (Ref EMEI Vehicle G 623).

UNCONTROLLED IF PRINTED

- 9. Repair.** Repair the diverter valve as follows (Figure 2):
- a. Remove the four solenoid cover screws (Figure 2, item 1) and the solenoid cover (Item 2). Remove and discard the O rings (Item 3) and (Item 4).
  - b. Remove the four end plate screws (Item 20) end plate (Item 19) and gasket (Item 18).
  - c. Unscrew the push pin guide (Item 17) from the valve body (Item 11).
  - d. Unscrew the guide tube (Item 5) from the valve body.
  - e. Remove and discard the O rings (Item 6, 15 and 16).
  - f. Remove and discard the springs (Item 8 and 13) centering washers (Item 9 and 12) and push pins (Item 7 and 14).
  - g. Clean and inspect the valve body (Item 11), spool (Item 10), the solenoid assembly and the cover (Item 2). Replace any worn or damaged item.
  - h. Assemble the new pin guide (Item 17) with O rings (Item 15 and 16), push pin (Item 14), spring (Item 13) and spring centering washer (Item 12).
  - i. Insert and tighten the push pin guide (Item 17) into the valve body (Item 11).
  - j. Fit and secure the end-plate gasket (Item 18) and end-plate (Item 19) with the four screws (Item 20).
  - k. Slide the spool (Item 10) into the valve body and engage the spool into the centering washer (Item 12).
  - l. Assemble the guide tube (Item 5) with new O ring (Item 6), push pin (Item 7), spring (Item 8) and centering washer (Item 9).
  - m. Screw the guide tube (Item 5) into the valve body.
  - n. Fit new O rings (Item 3 and 4) into the solenoid and solenoid cover (Item 2).
  - o. Attach the solenoid cover (Item 2) to the valve body (Item 11) with the four screws (Item 1).
- 10. Installation.** Install the diverter valve to the adapter (Ref EMEI Vehicle G 623) and operate the crane (Ref EMEI Vehicle G 622). Check that the response to each control lever movement is correct.

**Table 2 Annotation to Figure 2**

Item	Description	Item	Description	Item	Description	Item	Description
1	Solenoid cover screw	6	O ring	11	Valve body	16	O ring
2	Solenoid cover	7	Push pin	12	Spring centering washer	17	Push pin guide
3	O ring	8	Spring	13	Spring	18	End-plate gasket
4	O ring	9	Spring centering washer	14	Push pin	19	End-plate
5	Guide tube	10	Spool	15	O ring	20	End plate screw

UNCONTROLLED IF PRINTED

UNCONTROLLED IF PRINTED

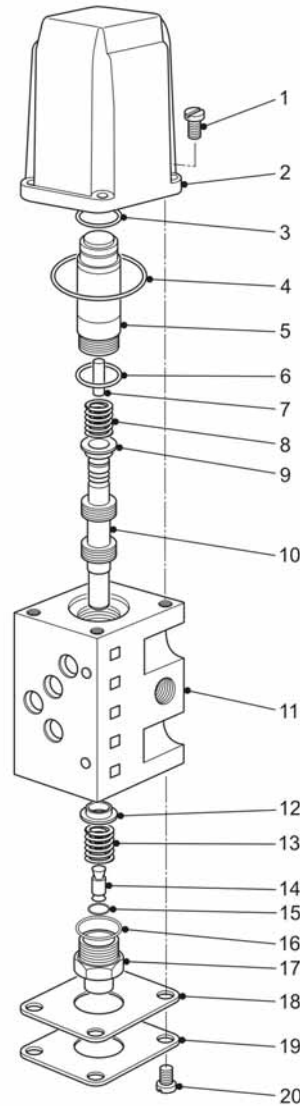

Figure 2 Diverter Valve Components

**Directional Control Valve Bank**

- 11. **Removal.** Remove the directional control valve bank in accordance with EMEI Vehicle G 623.
- 12. **Repair.** Repair the directional control valve bank as follows (Figure 3):

**NOTE**

To facilitate the correct assembly of the valve items care must be taken to note the order of disassembly.

- a. Remove and discard the main relief valve assembly (Figure 3, item 2) from the oil inlet control valve (Item 1).
- b. Remove and discard the spring assembly (Item 4), relief valve assembly (Item 9) and the plug assembly (Item 11) from the stabiliser and slewing control valves (Item 3) and the inner, outer and extension boom control valves (Item 5).
- c. Remove and discard the check valve assembly (Item 8) from the oil outlet control valve (Item 6).

**NOTE**

If oil leaks are suspected between each of the control valves (Item 1, 3 and 5) it will necessitate the removal of the four studs (Item 7) to renew the packing ring sets (Item 10).

- d. Clean and inspect each control valve body for wear or damage. Replace if necessary.
- e. Fit the new main relief valve assembly (Item 2) into the oil inlet control valve (Item 1).
- f. Fit a new spring assembly (Item 4), new relief valve assembly (Item 9) and new plug assembly (Item 11) into the stabiliser and slewing control valves (Item 3) and the inner, outer and extension boom control valves (Item 5).
- g. Fit a new check valve assembly (Item 8) into the oil outlet control valve (Item 6).

**13. Installation.** Install the directional control valve (Ref EMEI Vehicle G 623) and operate the crane (Ref EMEI Vehicle G 622). Check that the response to each control lever movement is correct.

**Table 3 Annotation to Figure 3**

Item	Description	Item	Description	Item	Description
1	Oil inlet control valve	5	Inner, outer and extension booms control valves	9	Relief valve assembly
2	Main relief valve assembly	6	Oil outlet control valve	10	Packing ring set
3	Stabiliser and slewing control valves	7	Stud	11	Plug assembly
4	Spring assembly	8	Check valve assembly		

UNCONTROLLED IF PRINTED

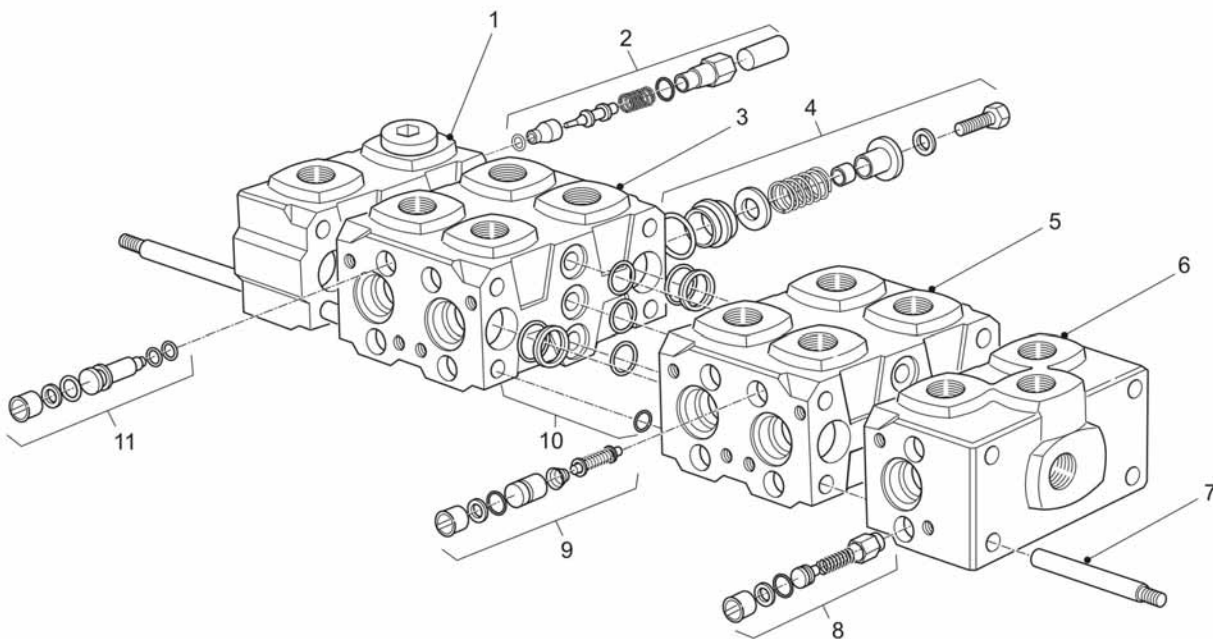

DE(EMEI)3551-3

**Figure 3 Directional Control Valve Bank Components**

**END**

Distribution List: **VEH G 26.0 – Code 3** (Maint Level)  
(Sponsor: LV SPO, Med/Hvy B Vehicles)  
(Authority: TRAMM)