

**TRUCK, CARGO, LIGHT AND TRUCK, CARGO, LIGHT, WINCH,
MC2 - LAND ROVER 110 6X6**

SERVICING INSTRUCTION

This instruction is authorised for use by command of the Chief of Army. It provides direction, mandatory controls and procedures for the operation, maintenance and support of equipment. Personnel are to carry out any action required by this instruction in accordance with EMEI General A 001.

Introduction

1. This EMEI lists the requirements for each level of servicing for Truck, Cargo, Light, MC2 Land Rover 110 6x6 All Types. Table 2 details the frequency of each level of servicing. Table 3 details the actions to be performed at each of the levels of servicing by both the operator and tradesperson.

Items Previously Known To Have Contained Asbestos

WARNING

Asbestos is a hazardous material and a carcinogen. Airborne asbestos fibre poses a serious danger to personnel and can lead to acute health concerns and eventual death.

The Land Rover Family of Vehicles (FOV) was originally fitted with a number of gaskets, seals and washers known to have contained asbestos.

Since 2009, all genuine Land Rover Australia supplied repair parts including; gaskets, seals and washers are asbestos free. If it is unknown as to whether the material contains asbestos, such items are to be removed, handled and disposed of IAW Defence WHSManual.

NOTE

Prior to the disruption, removal or replacement of items contained within Table 1, the vehicle logbook (GM120) should be reviewed. If the item has been replaced since 2009 and noted in Part 4 of the GM120 the item can safely be handled as being asbestos free.

2. The following table provides a list of all known, in-situ, items including; parts, gaskets, seals and washers found in Land Rover 4X4 FOV which may contain asbestos. If an item in Table 1 is to be replaced, the GM120, Part 4 should be reviewed. If the item in question has been replaced after 2009 and noted in Part 4 of the GM120 the item can safely be handled as being asbestos free. If no evidence can be found in Part 4 the item is to be considered contaminated with asbestos. The item is to be replaced IAW Defence WHSManual Vo1 2, Part 3A, Chap 5; Asbestos Management in Defence and recorded in the GM120 Part 4.

Table 1 Items Previously Known To Have Contained Asbestos

Serial	ACM NIIN	NON-ACM NIIN	Item name	Description	RPS: 02185 ISSUE 3 MAR 00	Entry into GM120 Part 4 YES/NO
1	991373054	661566324	Gasket, transmission magnetic plug	Fibre washer for the transmission magnetic plug	FBA 016	
2	991373055	661566325	Gasket, transmission oil strainer plug	Filler plug fibre washer	FBA 021 / FBB 006	
3	661284266	661285409	Gasket, exhaust manifold	Exhaust manifold gasket	ABA 020	
4	998221518	661566345	Gasket, cover plate transfer casing reverse idler access	Transmission side plate gasket	FBA 012	
5	998221724	661566352	Gasket, transfer casing lower cover plate	Transfer case bottom plate gasket	FBB 001	
6	998221850	661566360	Gasket, transmission pneumatic valve	PTO actuator fibre washer	FEA 024	
7	998240915	661566354	Gasket, transmission oil pump cover	Transmission oil pump cover gasket	FC 019	
8	998498732	661566323	Gasket, transmission oil pump cover	Filler plug gasket for transfer case, front axle housing, rear / intermediate axle housing.	FBA 014 / FBC 012 / JA 903 / KA 006	
9	997980214	994957906	Brake shoe set, transmission handbrake	Handbrake brake shoes	MFB 001	
10	998221517	661566341	Gasket, transmission top cover plate	Transmission top plate gasket	FBA 010	
11	996666734	661566343	Gasket Housing Dog Clutch	PTO Actuator housing gasket	FBC 026	
12	998238297	661568461	Ring oil pick up	Transmission front cover plate oil pickup ring	FC 010	
13	661284264	661586333	Gasket	Oil cooler housing gasket	BE 009	
14	997628209	661566325	Joint washer	Filler plug fibre washer transfer case	FBA 021 / FBB 006	
15	998221722	661566353	Gasket Speedometer case	Speedo drive housing gasket	FBC 015	
16	997920835	661566324	Gasket Magnetic Plug	Filler plug fibre washer transfer case	FBA 016	

General Safety Warnings

WARNING

All industrial safety, work practices and equipment operating and maintenance instructions pertaining to this EMEI are to be adhered to.

The handling, storage and use of chemical substances are to be in accordance with WHSManual, ChemAlert and EMEI Workshop E series requirements.

Under no circumstances is compressed air to be used to remove dust from the clutch assembly and flywheel housing or the brake drums/discs and brake linings. Dust from the brake linings can be a health risk if inhaled.

Associated Publications

- 3.** For maintenance and repair procedures, reference may be necessary to the latest issue of the following publications:
- a.** EMEI Misc Equip Q 208 – Inspection of Portable Fire Extinguishers;
 - b.** EMEI Vehicle A 291-1 – Tyres and Tubes – Care and Maintenance of B Vehicles;
 - c.** EMEI Vehicle A 291-5 – Tyres and Tubes – Australian Defence Force B Vehicle Tyre Guide;
 - d.** EMEI Vehicle A 298-2 – Tyres and Tubes – General Service B Vehicle Tyres;
 - e.** EMEI Vehicle A 429-1 – Brake Systems – B Vehicles General – Brake Shoe Re-lining Policy;
 - f.** EMEI Vehicle A 453-2 – Hydraulic Brake Systems – Re-sleeving of Master and Wheel Cylinders;
 - g.** EMEI Vehicle A 459-2 – Hydraulic Brake Systems – B Vehicle Hydraulic Brake Fluid Deterioration;
 - h.** EMEI Vehicle A 468-1 – Crack Inspection of Land Rover Wheel Rim;
 - i.** EMEI Vehicle A 548-1 – Vehicle Seat Belts – Inspection Data;
 - j.** EMEI Vehicle A 591-1 – Inspection and Cleaning of Dry Type Air Cleaner Elements;
 - k.** EMEI Vehicle D 108 – Recovery Equipment – Inspection of Recovery Equipment;
 - l.** EMEI Workshop E 544 – Occupational Health and Safety – Safety Inspections and Testing of Electrical Equipment;
 - m.** EMEI Vehicle G 008-1 – Inspection and Repair of Towing Pintle Assembly;
 - n.** EMEI Vehicle G 187-16 – Conversion from Oil Filled to Grease Filled Swivel Pin Housings;
 - o.** EMEI Vehicle G 188 – Inspection Guidelines;
 - p.** EMEI Vehicle G 188-1 – Suspension and Steering Inspection Procedure;
 - q.** EMEI Vehicle G 189-8 – Location and Restriction on the Use of the Power Distribution Box;
 - r.** EMEI Vehicle G 189-17 – Chassis Crack Inspection and Repair;
 - s.** EMEI Vehicle G 203 – Truck, Cargo, Light and Truck, Light, Winch, MC2 – Land Rover 110 6x6 – Light Grade Repair;
 - t.** EMEI Vehicle G 204-1 – Truck, Cargo, Light and Truck, Light, Winch, MC2 – Land Rover 110 6x6 – Medium Grade Repair;
 - u.** EMEI Vehicle G 204-2 – Truck, Cargo, Light and Truck, Light, Winch, MC2 – Land Rover 110 6x6 – Heavy Grade Repair;
 - v.** EMEI Vehicle G 223 – Truck, Ambulance, Light, Four Litter, FFR, Winch, MC2 – Land Rover 110 6x6 – Light Grade Repair;
 - w.** EMEI Vehicle G 224-1 – Truck, Ambulance, Light, Four Litter, FFR, Winch, MC2 – Land Rover 110 6x6 – Medium and Heavy Grade Repair;
 - x.** EMEI Vehicle G 233 – Truck, Long Range Patrol, Light, Winch, MC2 – Land Rover 110 6x6 – Light Grade Repair;
 - y.** EMEI Vehicle G 234-1 – Truck, Long Range Patrol, Light, Winch, MC2 – Land Rover 110 6x6 – Medium and Heavy Grade Repair;
 - z.** EMEI Vehicle G 243 – Truck, General Maintenance, Light, Winch, MC2 – Land Rover 110 6x6 – Light Grade Repair;
 - aa.** EMEI Vehicle G 244-1 – Truck, General Maintenance, Light, Winch, MC2 – Land Rover 110 6x6 – Medium and Heavy Grade Repair;
 - bb.** EMEI Vehicle G 253 – Truck, Electronic Repair and Truck, Comsec Repair, Light, Winch, MC2 – Land Rover 110 6x6 – Light Grade Repair;
 - cc.** EMEI Vehicle G 254-1 – Truck, Electronic Repair and Truck, Comsec Repair, Light, Winch, MC2 – Land Rover 110 6x6 – Medium and Heavy Grade Repair;

- dd.** EMEI Vehicle G 263 – Truck, Cargo, Light, Crew Cab, Winch, MC2 – Land Rover 110 6x6 Parakeet – Light Grade Repair;
- ee.** EMEI Vehicle G 264-1 – Truck, Cargo, Light, Crew Cab, Winch, MC2 – Land Rover 110 6x6 Parakeet – Medium and Heavy Grade Repair;
- ff.** EMEI Vehicle G 273 – Truck, Light, Infantry and Mortar Carriers, FFR, Winch, MC2 and Truck, Light, Assault Pioneer, Winch, MC2 and Truck, Light, Direct Fire Weapons, FFR, Winch, MC2 - Land Rover 110 6x6 – Light Grade Repair (Note: EMEI Vehicle G 273 is yet to be issued at the time of authoring this document);
- gg.** EMEI Vehicle G 274 – Truck, Light, Infantry and Mortar Carriers, FFR, Winch, MC2 and Truck, Light, Assault Pioneer, Winch, MC2 and Truck, Light, Direct Fire Weapons, FFR, Winch, MC2 - Land Rover 110 6x6 – Medium Grade Repair (Note: EMEI Vehicle G 274 is yet to be issued at the time of authoring this document);
- hh.** EMEI Vehicle G 274-1 – Truck, Light, Infantry and Mortar Carriers, FFR, Winch, MC2 and Truck, Light, Assault Pioneer, Winch, MC2 and Truck, Light, Direct Fire Weapons, FFR, Winch, MC2 - Land Rover 110 6x6 – Heavy Grade Repair (Note: EMEI Vehicle G 274-1 is yet to be issued at the time of authoring this document);
- ii.** EMEI Vehicle G 283 – Truck, Air Defence, Land Rover 6x6, FFR, w/Winch, Fire Unit Vehicle (FUV) – Light Grade Repair;
- jj.** EMEI Vehicle G 284-1 – Truck, Air Defence, Land Rover 6x6, FFR, w/Winch, Fire Unit Vehicle (FUV) – Medium Grade Repair;
- kk.** EMEI Vehicle G 403 – Truck, Air Defence, Land Rover 6x6, FFR, w/Winch, Target Sensor Vehicle (TSV) – Light Grade Repair;
- ll.** EMEI Vehicle G 404-1 – Truck, Air Defence, Land Rover 6x6, FFR, w/Winch, Target Sensor Vehicle (TSV) – Medium Grade Repair;
- mm.** EMEI Vehicle A 008-1 – Technical Inspection Of B Vehicles, Trailers, Motorcycles And All Terrain Vehicles (ATV);
- nn.** EMEI Workshop H 149-1 – Hydraulic (Bottle) Vehicle Jacks – Inspection and Servicing;
- oo.** [Defence Work Health and Safety Manual](#) (WHSSManual);
- pp.** [Electronic Supply Chain Manual \(ESCM\)](#);
- qq.** [ChemAlert](#);
- rr.** [Technical Regulation of ADF Materiel Manual - Land version 5](#)(TRAMM-L); and
- ss.** RPS 02185 – Truck, Cargo, Light, MC2, 6x6, 2 Tonne, 3.9 Litre Turbocharged Diesel Engine, Manual Transmission, 12/24 V, Landrover 110;

Servicing Points

- 4.** Servicing points are identified as follows:
 - a.** Figure 1 Chassis Servicing Points, All Types;
 - b.** Figure 2 Engine Servicing Points, All Types; and
 - c.** Figure 3 Winch Servicing Points.

Servicing Schedule

5. Table 1 lists the servicing schedule.

Table 2 Servicing Schedule

Type of Service	Period
Land Rover 12 month Insp	12 months after the last scheduled service
Minor	Every 10 000 km or 24 months, whichever occurs first after the last Major/Alternate Major Service
Major	Every 20 000 km or 48 months, whichever occurs first after the last Alternate Major Service
Alternate Major	Every 40 000 km or 96 months, whichever occurs first after the last Alternate Major Service

Servicing Sequence

6. The following is the servicing sequence that is to be applied to all Land Rover 110 6x6 variants:

- a. Land Rover 12 month Insp – 12 months after an Alternate Major Service.
- b. Minor Service – 10 000 km or 24 months from an Alternate Major Service.
- c. Land Rover 12 month Insp –12 months after the last Minor Service.
- d. Major Service – 10 000 km or 24 months from last Minor Service.
- e. Land Rover 12 month Insp –12 months after the last Major Service.
- f. Minor Service – 10 000 km or 24 months from last Major Service.
- g. Land Rover 12 month Insp –12 months after the last Minor Service.
- h. Alternate Major Service – 10 000 km or 24 months after the second minor service has been carried out.
- i. The servicing sequence commences again after the Alternate Major Service, with a Land Rover 12 month Insp Check being carried out after 12 months.

7. Servicing is based on distance travelled or elapsed time, with all vehicles being serviced at least once every 24 months. Unit commanders may reduce the period between services or add servicing tasks to meet operational or exercise requirements. A scheduled service may be anticipated or delayed within a limit of plus or minus 10 per cent of the interval between services to meet operational needs and to permit workload planning.

NOTE

When any equipment exceeds the 10 per cent maximum limit of the servicing interval (Table 1), it is to be classified ‘**Do Not Use – XX**’ until the outstanding service is completed.

Authorised Personnel

- 8. All operator tasks are to be carried out by a qualified operator under the supervision of personnel nominated at Para 8.
- 9. All tradesperson tasks are to be carried out by the following tradesperson as applicable to the task:
 - a. Vehicle Mechanic (ECN 229);
 - b. Recovery Mechanic (ECN 226);
 - c. Technician Electrical (ECN 418);
 - d. Fitter Armourer (ECN 146); or
 - e. tri-service/civilian equivalent.

Standard Job

10. MILIS standard job numbers have been raised to detail the vehicle servicing procedures. The following standard job numbers have been allocated:

- a. Land Rover 6x6 12 month Tech Insp – 007860;
- b. Minor Service – 000496;
- c. Major Service – 000495; and
- d. Alternate Major Service – 000497.

Additional Tasks

11. No additional tasks are to be added to scheduled maintenance work orders. A separate, linked work order shall be raised to record additional maintenance tasks identified during the servicing and/or the Technical Inspection (TI). These additional tasks may include, but not be limited to, the replacement of wheel bearings, brake pads/shoes, wheel cylinders, etc. and outstanding modifications. The additional tasks are to be completed in conjunction with the scheduled maintenance.

Table 3 Servicing Requirements

Serial	Item or Assembly (1)	Land Rover 6x6 12 month Inspection 12 Mths	Minor Service 10 000 km or 24 Mths	Major Service 20 000 km or 48 Mths	Alternate Major Service 40 000 Km or 96 Mths	Capacity (Litres)	Lubricant
Operator tasks (to be performed under supervision Para 8)							
1	Engine oil	-	D	D	D	8.5	SAE GRADE 40 (OMD-115)
2	Engine oil filter	-	R	R	R		
3	Fuel filter	-	R	R	R		
4	Engine breather filter	-	C	C	C		
5	Water pump (if fitted with nipple)	-	L	L	L		XG-291
6	Remove air cleaner	-	AR	AR	AR		
7	Air cleaner dust vacuator valve	-	C	C	C		
8	Radiator coolant (Ref Para 13)	-	T	D	D	12.5	Water and inhibitor
9	Fuel transfer pump strainer	-	C	C	C		
10	Windscreen washer bottle	-	T	T	T		
11	Power steering system	-	T	-	-		OX-46
12	Bonnet locks and hinges	-	L	L	L		SAE GRADE 40 (OMD-115)
13	Heater intake dump valve	-	C	C	C		
14	Accelerator control linkage and pedal pivot	-	L	L	L		SAE GRADE 40 (OMD-115)
15	Hinges, catches and latches	-	L	L	L		SAE GRADE 40 (OMD-115)
16	Fan belt jockey-pulley bearing (if fitted)	-	L	L	L		XG-291
17	Battery electrolyte level (bottom of the filler spouts), security and cleanliness of terminals	-	T, C, I	T, C, I	T, C, I		

Table 3 Servicing Requirements (Continued)

Serial	Item or Assembly (1)	Land Rover 6x6 12 month Inspection	Minor Service	Major Service	Alternate Major Service	Capacity (Litres)	Lubricant
		12 Mths	10 000 km or 24 Mths	20 000 km or 48 Mths	40 000 Km or 96 Mths		
18	Seat slides	-	L	L	L		SAE GRADE 40 (OMD-115)
19	Driving mirrors and window glasses	-	C, I	C, I	C, I		
20	Demount tyres for rim inspection	-	AR	AR	AR		
21	Tyres (inflate after the rim inspection, if necessary, including the spare)	-	T	T	T		
22	Wheel nut security	-	Y	Y	Y		
23	Fuel sedimenters (Ref Para 15)	-	C	C	C		
24	Winch gearbox	-	T	T	D	2.1	OEP-220
25	Front axle	-	T	T	D	1.7	OEP-220
26	Swivel pin housings (Ref EMEI Vehicle G 187-16)	-	I	I	I	Pre- packaged in applicator	NSN 9150-99- 911-1798
27	Transmission	-	T	T	D	2.7	SAE GRADE 40 (OMD-115)
28	Transfer case	-	T	T	D	3.2	SAE GRADE 40 (OMD-115)
29	Transfer case with PTO	-	T	T	D	5.8	SAE GRADE 40 (OMD-115)
30	Intermediate axle	-	T	T	D	2.3	OEP-220
31	Rear axle	-	T	T	D	2.7	OEP-220
32	Park brake and PTO linkage	-	L	L	L		XG-291
33	Axle and transmission breathers	-	C	C	C		
34	Axle rebound cables	-	I	I	I		
35	Propeller shafts, support bearings, sliding and universal joints	-	L	L	L		XG-291
36	Propeller shaft bolts	-	Y	Y	Y		
37	Winch fairleads and rollers	-	L	L	L		SAE GRADE 40 (OMD-115)
38	Winch propeller shaft and support bearings	-	L	L	L		XG-291
39	Winch dog clutch	-	L	L	L		XG-291
40	Winch rope (Para 19)	-	C, L	C, L	C, L		Rocol wire rope lube NSN 9150- 99-337-1498
41	Spare wheel/s carrier operation	-	I	I	I		
42	Pintle hook	-	L	L	L		XG-291
43	CES	-	I	I	I		

Table 3 Servicing Requirements (Continued)

Serial	Item or Assembly (1)	Land Rover 6x6 12 month Inspection	Minor Service	Major Service	Alternate Major Service	Capacity (Litres)	Lubricant
		12 Mths	10 000 km or 24 Mths	20 000 km or 48 Mths	40 000 Km or 96 Mths		
44	Vehicle jack (Ref EMEI Workshop H 149-1)	-	I	I	I		
45	Fire extinguisher inspection tag (Ref EMEI Misc Equip Q 208)	-	I	I	I		
46	Vehicle cleanliness (clean as directed by supervising tradesperson)	-	C	C	C		
FFR							
47	Fit and test operation of radios	-	I	I	I		
LRPV							
48	Radiator screen	-	C	C	C		
49	Machine gun pivots and pedestal	-	L	L	L		XG-291
50	Motorcycle cradle (if fitted)	-	L	L	L		SAE GRADE 40 (OMD-115)
Tradesperson Tasks (Para 9)							
51	Air compressor operation (if fitted)	-	I	I	I		
52	Fuel injection pump and lines	-	I	I	I		
53	Air cleaner (Ref Para 12)	-	C	C	C		
54	Engine idle	-	A	A	A		
55	Fanbelts	-	I, A	I, A	I, A		
56	Fanbelt jockey-pulley (if fitted)	-	I, A	I, A	I, A		
57	Alternator mounting bolts	-	Y	Y	Y		
58	Intake and exhaust manifold bolts	-	Y	Y	Y		
59	Turbocharger bolts	-	Y	Y	Y		
60	Engine mounting and earth strap	-	I	I	I		
61	Valve clearances	-	-	A	A		
62	Fuel injectors (Ref Para 16)	-	-	-	I		
63	Engine compression (Ref Para 16)	-	-	-	I		
64	Glow plugs electrical circuit	-	-	I	I		
65	Engine stop control and hand throttle connection and operation	-	I	I	I		
66	Water pump condition	-	I	I	I		
67	Power steering system	-	-	D	D	1.25	OX-46
68	Radiator and hose condition	-	I	I	I		
69	Oil, coolant and fuel leaks	-	I	I	I		

Table 3 Servicing Requirements (Continued)

Serial	Item or Assembly (1)	Land Rover 6x6 12 month Inspection	Minor Service	Major Service	Alternate Major Service	Capacity (Litres)	Lubricant
		12 Mths	10 000 km or 24 Mths	20 000 km or 48 Mths	40 000 Km or 96 Mths		
70	Flywheel housing (Drain)	-	AR	AR	AR		
71	Exhaust system for leaks, damage and security	-	I	I	I		
72	Windscreen wipers, wiper blades and washers	-	I	I	I		
73	Windscreen and side windows, glass and seals	-	I	I	I		
74	Brake, fuel and clutch pipes for chaffing, leaks or corrosion	-	I	I	I		
75	Brake master cylinder leaks	-	I	I	I		
76	Brake servo filters	-	-	-	R		
77	Brake servo hose condition and operation	-	I	I	I		
78	Front, intermediate and rear hub bearings	-	A	A	I, L, A		XG-291
79	Front, intermediate and rear brake pads for wear, calipers for leaks and condition of the discs	-	I	I	I		
80	Brake hydraulic system (Ref EMEI Vehicle A 459-2 and Para 14)	D, B	D, B	D, B	D, B		OX-8
81	Clutch master and slave cylinder leaks	-	I	I	I		
82	Clutch hydraulic system	-	D, B	D, B	D, B		OX-8
83	Transmission mountings and earth strap	-	I	I	I		
84	Propeller shaft, centre bearing, universal joints and sliding joint	-	I	I	I		
85	Winch propeller shaft and support bearing	-	I	I	I		
86	Park brake, PTO linkage and cable	-	I, A	I, A	I, A		
82	Clutch hydraulic system	-	D, B	D, B	D, B		OX-8
83	Transmission mountings and earth strap	-	I	I	I		
84	Propeller shaft, centre bearing, universal joints and sliding joint	-	I	I	I		
85	Winch propeller shaft and support bearing	-	I	I	I		
86	Park brake, PTO linkage and cable	-	I, A	I, A	I, A		
87	Suspension and steering (Ref EMEI Vehicle G 188-1)	AR	AR	AR	AR		
88	Steering protection plate for damage and security	-	I	I	I		
89	Tyre and rim (Ref Para 20)	-	I	I	I		

Table 3 Servicing Requirements (Continued)

Serial	Item or Assembly (1)	Land Rover 6x6 12 month Inspection	Minor Service	Major Service	Alternate Major Service	Capacity (Litres)	Lubricant
		12 Mths	10 000 km or 24 Mths	20 000 km or 48 Mths	40 000 Km or 96 Mths		
90	Wheel rim (Ref EMEI Vehicle A 468-1)	-	I	I	I		
91	Wheel alignment	-	I	I	I		
92	Chassis (Ref EMEI Vehicle G 189-17)	-	I	I	I		
93	Panel damage	-	I	I	I		
94	Canopy and bows	-	I	I	I		
95	Seat belts, mountings and inertia reel operation (Ref EMEI Vehicle A 548-1)	I	I	I	I		
96	Heater and vent cables	-	I	I	I		
97	Bonnet lock operation and adjustment (Ref EMEI Vehicle G 203)	-	I, A	I, A	I, A		
98	Bonnet hinges (Ref EMEI Vehicle G 203)	-	I	I	I		
99	Headlight alignment	-	I, A	I, A	I, A		
100	Operation of lights, gauges, warning lights and horn	-	I	I	I		
101	Operation of foot brake, hand brake and clutch	-	I	I	I		
102	Winch operation	-	I	I	I		
103	Winch Rope and CES recovery items (Ref Para 19)	-	I	I	I		
104	NATO plug	-	I	I	I		
105	Pintle hook (Ref EMEI Vehicle G 008-1)	-	I	I	I		
106	Vehicle jack (Ref EMEI Workshop H 149-1)	I	I	I	I		
107	Rectification/Additional tasks (Ref Para 11)	AR	AR	AR	AR		
108	Racking module security	-	I	I	I		
AD Fire Unit Vehicle							
109	RBS 70 missile containers integrity, security, operation of latches and condition of seals (Ref Para 17)						
110	Clamps, latches and web strapping						
AD Target Sensor Vehicle							
111	Racking module security	-					
112	Clamps, latches and web strapping	-					
AD Target Sensor Vehicle							
111	Racking module security	-	I	I	I		

Table 3 Servicing Requirements (Continued)

Serial	Item or Assembly (1)	Land Rover 6x6 12 month Inspection	Minor Service	Major Service	Alternate Major Service	Capacity (Litres)	Lubricant
		12 Mths	10 000 km or 24 Mths	20 000 km or 48 Mths	40 000 Km or 96 Mths		
112	Clamps, latches and web strapping	-	I	I	I		
Ambulance / Electronic Repair / COMSEC							
113	Receiver drier	-	-	R	R		
114	Air conditioner security	-	Y	Y	Y		
115	Compressor mounting and clutch bolts	-	Y	Y	Y		
116	Condenser core	-	C	C	C		
117	Refrigerant hoses	-	I	I	I		
118	Drain tubes for kinks or restriction	-	I	I	I		
119	Air conditioner oil level	-	-	T	T		OM-70
120	Evacuate air conditioner system (Ref Para 18)	-	-	D	D		R134A
121	Test air conditioner operation	-	I	I	I		
122	Module to chassis mounting bolts	-	Y	Y	Y		
123	Step and platform mounting bolts	-	Y	Y	Y		
124	Rear door mount latches and catches	-	L, Y	L, Y	L, Y		SAE GRADE 40 (OMD-115)
125	Module electrical components/system	I	I	I	I		
126	Operation of stowage drawers, cupboards and locks	-	I, L	I, L	I, L		XG-291
127	Gas struts	-	I	I	I		
128	Vents and covers	-	I	I	I		
129	Oxygen pipes free from obstruction (ambulance)	-	I	I	I		
130	Suction pump operates (ambulance)	-	I	I	I		
131	Litter rails and bolts (ambulance)	-	I, Y	I, Y	I, Y		
132	Operation of module electrical components (for e.g. Lighting, fans, internal comms)	-	I	I	I		
General Maintenance							
134	Module to chassis mounting bolts	-	Y	Y	Y		
135	Step and platform mounting bolts	-	Y	Y	Y		
136	Rear and side doors mount latches and catches	-	L, Y	L, Y	L, Y		SAE GRADE 40 (OMD-115)
137	Operation of stowage drawers, cupboards and locks	-	I, L	I, L	I, L		XG-291
138	Security and operation of workbench	-	I	I	I		
139	Gas struts	-	I	I	I		

Table 3 Servicing Requirements (Continued)

Serial	Item or Assembly (1)	Land Rover 6x6 12 month Inspection	Minor Service	Major Service	Alternate Major Service	Capacity (Litres)	Lubricant
		12 Mths	10 000 km or 24 Mths	20 000 km or 48 Mths	40 000 Km or 96 Mths		
140	Vents and covers	-	I	I	I		
141	Operation of module 240/415 V electrical components (battery charger, fan and fan assisted heater)	-	I	I	I		
142	Module electrical system (Ref Para 21)	I	I	I	I		
LRPV							
143	Roll bar security	I	I	I	I		
144	Operation of inspection light socket, tripmeter and compass	-	I	I	I		
All Variants							
145	Classification label (Ref Para 23)	AR	AR	AR	AR		
146	Road test in accordance with EME1 Vehicle G 188	AR	AR	AR	AR		
147	Record details of 12 month inspection in GM 120 Part 2 – Record of Service	AR	-	-	-		
148	Raise TI report (Ref EME1 Vehicle G 188 and Para 22)	AR	AR	AR	AR		
149	Record details of inspection in GM 120 Part 2 – Record of Inspection	AR	AR	AR	A/R		
150	Record details of service in GM 120 Part 2 – Record of Service	AR	AR	AR	AR		
<p>Legend: A – Adjust, AR – Action required, B – Bleed, C – Clean, D – Drain and Refill, I – Inspect, L – Lubricate, R – Replace, T – Top Up, Y – Tighten</p> <p>Note 1. Refer to Figures 1, 2 and 3</p> <p>Note 2: Task may involve parts which contain asbestos, for detailed instructions refer to paragraph headings:</p> <ol style="list-style-type: none"> a. Items Previously Known To Have Contained Asbestos, and b. General Safety Warnings. 							

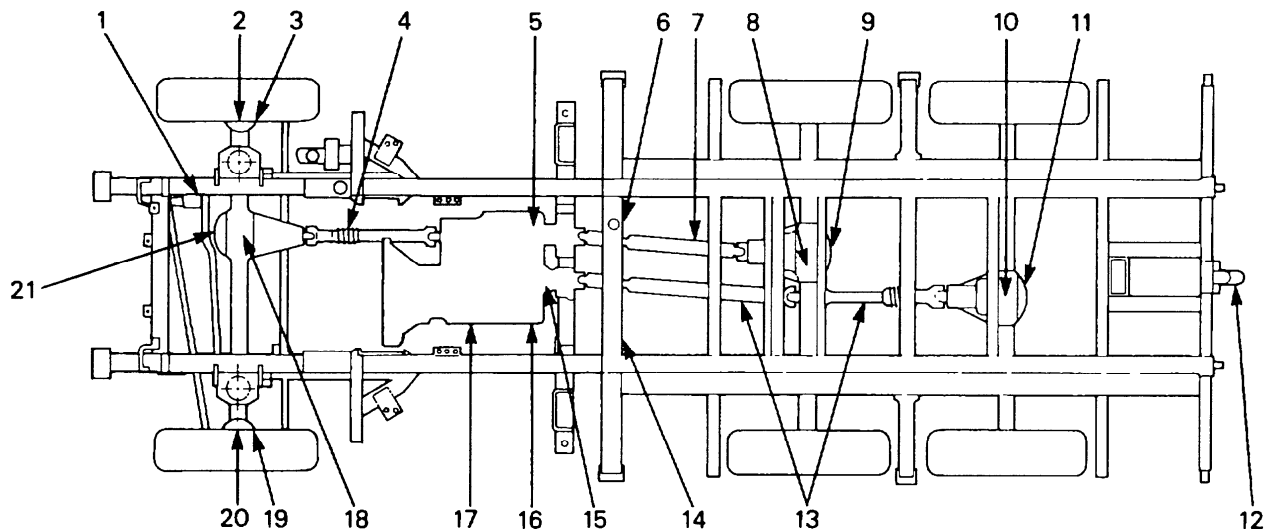

- | | |
|--|---|
| 1. Power steering reservoir | 12. Pintle |
| 2. Right hand swivel pin housing drain plug | 13. Rear propeller shaft grease nipples |
| 3. Right hand swivel pin housing fill plug | 14. Fuel sedimenter |
| 4. Front propeller shaft grease nipples | 15. Transfer case fill plug |
| 5. Transfer case drain plug | 16. Transmission fill plug |
| 6. Fuel sedimenter | 17. Transmission drain plug |
| 7. Intermediate propeller shaft grease nipples | 18. Front axle drain plug |
| 8. Intermediate axle drain plug | 19. Left hand swivel pin housing fill plug |
| 9. Intermediate axle fill plug | 20. Left hand swivel pin housing drain plug |
| 10. Rear axle drain plug | 21. Front axle fill plug |
| 11. Rear axle fill plug | |

Figure 1 Chassis Servicing Points, All Types

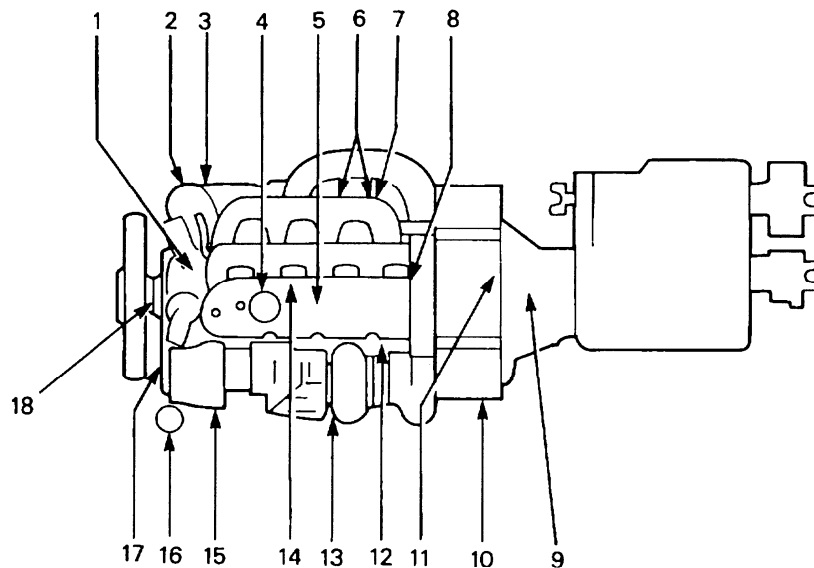

- | | | |
|-------------------------------------|----------------------------------|--------------------------------|
| 1. Coolant | 7. Crankcase breather | 13. Turbocharger bolts |
| 2. Fuel filter | 8. Accelerator cable and linkage | 14. Glow plugs |
| 3. Fuel transfer pump fuel strainer | 9. Flywheel housing drain plug | 15. Engine mountings |
| 4. Engine | 10. Air cleaner | 16. Air compressor (if fitted) |
| 5. Valve clearances | 11. Air cleaner vacuator valve | 17. Fanbelt |
| 6. Oil filters | 12. Cylinder head bolts | 18. Water pump |

Figure 2 Engine Servicing Points

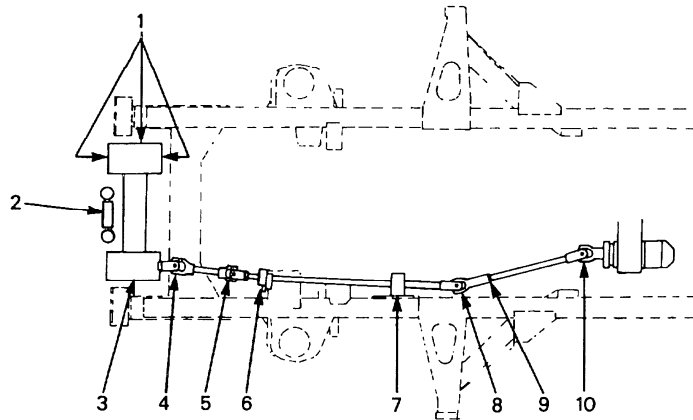

- | | | |
|----------------------------------|---------------------------------------|-----------------------------------|
| 1. Winch grease points | 5. Universal joint grease nipple | 8. Universal joint grease nipple |
| 2. Winch fairleads and roller | 6. Drop block bearing grease nipple | 9. Slip joint grease nipple |
| 3. Winch drain and fill plugs | 7. Pillow block bearing grease nipple | 10. Universal joint grease nipple |
| 4. Universal joint grease nipple | | |

Figure 3 Winch Servicing Points

General Information

12. Check the air restriction indicator and clean the primary element if the indicator is red. The safety element is not to be cleaned. The primary element can be washed with a non-sudsing general purpose detergent in accordance with EMEI Vehicle A 591-1. Remove the filter wrap and wash it in diesel or kerosene, wring it dry and lubricate it with unifilter oil or SAE Grade 40 (OMD-115).

13. The anti-freeze requirements are as follows:

- a. **No Anti-freeze Required.** When anti-freeze is not required, the cooling system must be flushed out with clean water and refilled with a solution of one part Nalcool inhibitor to 12 parts water, i.e. a minimum of 8% inhibitor in the coolant, or as otherwise directed by the instructions on the Nalcool container.
- b. **Anti-freeze Required.** When anti-freeze is required, the correct type is an ethylene glycol based anti-freeze (containing no methanol) with non-phosphate corrosion inhibitors suitable for use in cast iron engines. 33% anti-freeze by volume will provide protection down to -20 °C, whereas 50% anti-freeze by volume will provide protection down to -36 °C.

14. The brake system is to be drained, refilled and bled every 12 months in accordance with EMEI Vehicle A 459-2.

15. The fuel sedimenters are to be checked more frequently under field conditions.

16. Clean and spray test the injectors at 120 000 km and carry out a compression test.

17. **RBS 70 Missile Containers Pressure Test.** Pressure test the RBS 70 missile containers as follows:

- a. Open the missile tube access hatch to remove any pressure build-up in the tube.
- b. Remove the desiccant plug from the access hatch and install the 0–10 kPa pressure gauge (NSN 6685-66-128-6393).
- c. Close the access hatch.

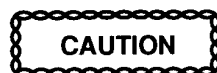

Do not exceed 7 kPa during the pressure test as damage to the missile tubes will occur.

- d. Apply a pressure of 7 kPa to the missile tubes using a hand operated tyre pump.

- e.** Observe the gauge for a period of five minutes. A pressure drop in excess of 0.5 kPa indicates a leaking access hatch gasket or a damaged missile tube (replace or repair as required).
 - f.** Open the access hatch to release the residual pressure.
 - g.** Remove the pressure gauge and install the desiccant plug.
 - h.** Close the access hatch.
- 18.** The air conditioning refrigerant must be recovered and not vented to the atmosphere.
- 19.** The winch rope is to be cleaned using mains pressure fresh water. The winch rope is not to be cleaned using high pressure cleaners. Once cleaned, the winch rope is to be inspected in accordance with EMEI Vehicle D 108 prior to lubricating. A winch rope classified **Fully Functional** can be wound back onto the winch drum. The recovery items (e.g. chain, shackles, etc.) that are part of the vehicle CES are to be inspected in accordance with EMEI Vehicle D 108. Inspection of the winch rope and recovery CES items is a part of servicing and must be completed if the vehicle is to be classified **Fully Functional**.
- 20.** Inspect the tyres for wear in accordance with EMEI Vehicle A 298-2. Inspect the rims for damage and that the correct rims are fitted in accordance with EMEI Vehicle A 469-1.
- 21.** Inspect and test the 240/415 V electrical system of the maintenance module in accordance with EMEI Workshop E 544.

Technical Inspection

- 22.** The vehicle is to have a complete technical inspection once every 24 months or at each service in accordance with EMEI Vehicle G 188 and a TI Report (Form GI041) completed or an Inspection Report completed and printed from the MSETEC screen in MILIS and inserted in the vehicle GM 120. If the vehicle classification changes within the 24 month period then a partial TI is required with the expiry date of that partial to be the last complete TI expiry date.
- 23. Useability Label.** The Vehicle Useability classification label needs to reflect the next Preventative Maintenance (PM) activity to be conducted within the authorised complete TI period. For example:
- a.** After a service and complete TI, the useability label will be fitted to reflect the current vehicle useability status from the current TI with the date entered as the next PM task due which would be a Land Rover 12 month Insp at 12 months.
 - b.** At a Land Rover 12 month Insp the useability label will need to be replaced to reflect the useability status from the last TI and the expiry date will be either the next PM task due or the last current complete TI expiry date.

END

Distribution List: **VEH G 20.0 – Code 2** (Maint Level)
(Sponsor: CGSVSPO, Light B Vehicles)
(Authority: EC-006640)